

Volume 1: Technical Report and Results

Final Report on

Performance, Durability,

and Service Life of

Low Pressure Propane

Vapor Regulators

Docket 11073

by

Stephanie Flamberg, Matt Goshe,

Rodney Osborne, and Steve Speakman

Battelle Applied Energy Systems

To

Propane Education

& Research Council

1140 Connecticut Ave. NW, Suite 1075

Washington, DC 20036

September 2006

FINAL REPORT

on

PERFORMANCE, DURABILITY, AND SERVICE LIFE OF LOW PRESSURE PROPANE VAPOR REGULATORS

Docket 11073

VOLUME 1 – TECHNICAL REPORT AND RESULTS

to

Propane Education & Research Council
1140 Connecticut Ave. NW, Suite 1075
Washington, DC 20036

September 2006

by

Stephanie Flamberg
Matt Goshe
Rodney Osborne
Steve Speakman

Battelle Applied Energy Systems
505 King Avenue
Columbus, Ohio 43201-2693

Battelle
The Business of Innovation

Notice

Battelle does not engage in research for advertising, sales promotion, or endorsement of our clients' interests including raising investment capital or recommending investments decisions, or other publicity purposes, or for any use in litigation.

Battelle endeavors at all times to produce work of the highest quality, consistent with our contract commitments. However, because of the research and/or experimental nature of this work the client undertakes the sole responsibility for the consequence of any use or misuse of, or inability to use, any information, apparatus, process or result obtained from Battelle, and Battelle, its employees, officers, or Directors have no legal liability for the accuracy, adequacy, or efficacy thereof.

ACKNOWLEDGMENTS

The authors wish to express their appreciation to the individuals and organizations who contributed to the successful completion of this challenging program. The authors sincerely appreciate the support in time, materials, and shipping expenses for those propane marketers and National Propane Gas Association members that supplied regulators for this testing program and the efforts of the Propane Education & Research Council and NPGA to assist with the collection of the regulator samples for testing. In addition, we would also like to thank the regulator manufacturers and industry experts that provided feedback on the regulator test protocol. This project would not have been a success without their assistance.

The authors also wish to acknowledge the program advice and guidance provided by Larry Osgood of Consulting Solutions on behalf of PERC. Larry imparted into the program the practical propane industry experience very necessary in this type of project.

This page intentionally left blank.

EXECUTIVE SUMMARY

Anecdotal evidence suggests that the natural gas industry effectively and safely uses low pressure regulators in field service for time periods exceeding 30 years. Yet in the propane industry, regulator manufacturers provide regulators that have limited field evaluation capability and regularly carry a 15-year replacement recommendation. To gain a clear understanding of the issues and concerns, the Propane Education & Research Council (PERC) obtained the assistance of Battelle to test a suite of propane vapor regulators that have been recently removed from service and to develop a database on their performance. Regulators considered for this study were standard non-adjusting residential and commercial vapor regulators. Regulators intended for industrial applications, “pounds-to-pounds” regulation, and those intended to be adjusted on a regular basis were excluded from this study.

This report summarizes the results of a program conducted by Battelle in which propane vapor regulators, in use from 1 to more than 50 years, were collected from across the country and subjected to a series of tests to determine their performance. Over seven hundred first-stage, second-stage, single-stage, and integral two-stage (includes twin stage and combo) regulators were collected from 27 different states, representing four climate regions. The collection included regulators from different manufacturers, different types of regulators, various service conditions, ages, and environmental conditions. The collection effort specifically targeted first-stage, second-stage, and integral two-stage regulators to examine the assumptions behind the 15-year replacement recommendations. A sampling of single-stage regulators was also tested; however, since the 1995 edition of NFPA 58, the LP-Gas Code, these regulators have not been permitted to be placed into new service and therefore the testing efforts did not focus on their performance.

As part of this project, the Gas Technology Institute performed a literature review to determine if there was scientific or engineering support for a 15-year replacement recommendation.

The literature review was not able to document scientific or engineering support for a service-life recommendation of 15-years.

The findings of the literature review suggest further research in the use and variability of plasticizers and extenders in the rubber composition of propane regulator components; the long-term effect a propane operating environment has on elastomer and spring performance; and the effect of propane contaminants and off-specification gas on propane regulator performance.

A technical paper studying regulators in Korea¹ showed that in general the safety devices of the low pressure regulators deviated from “normal operation” (not defined by the authors) after a year of service and deviated from the factory-set discharge start and reset pressures of the new regulators. Overall, the operating and closing pressures also deviated from the pressure range of the new regulators after a year of service. A six year service life was then recommended. Testing of diaphragms from the propane regulators in the field found a loss of tensile strength and

¹ Jeong-Rock Kwon, Young-Gyu Kim Gas Safety R&D Center, Korea Gas Safety Corporation, “Aging Characteristics of Low Pressure LPG Regulators for Domestic Use”, May 1999.

decreased range of motion after five years of service. Researchers suspect a hardening of the diaphragms due to leaching of plasticizers from rubber materials over time. The authors called for further research to improve diaphragm durability and reliability, to investigate the effect of plasticizer extraction from rubber materials on diaphragm performance, and the development of new rubber materials with improved rubber characteristics and properties. Testing of propane regulator springs from the field found a loss in tensile strength after a seven-year service life. The authors called for spring research on the length of the freedom field of the spring, the surface treatment on the ending parts of the spring, quality control in the manufacturing, and reinforcement of durability characteristics. It should be noted that none of the regulators tested were from U.S. manufacturers. However, the Korean study does raise the issue of the long-term effects a propane operating environment has on elastomer and spring performance.

Additionally, a review of elastomers reference literature, “The Vanderbilt Rubber Handbook – 13th Edition,”² and “Rosato’s Plastics Encyclopedia and Dictionary,”³ found that additives, particularly plasticizers and extenders, can leach out over time, resulting in physical changes in size, elongation, and tear strength. In regulators, elastomers are used in valve seat discs and diaphragms. Further research is suggested to assess the use and variability of plasticizers and extenders in the rubber composition of propane regulator components.

In “Investigation of Portable or Handheld Devices for Detecting Contaminants,”⁴ findings indicate that while propane for domestic use typically meets commercial grade specifications, contamination occurs in small quantities in the supply chain over time. Further, the impact of propane contaminants and off-specification gas is not well documented. Research is suggested to investigate the effect of propane contaminants and off-specification gas on U.S. propane regulator performance.

To test the performance of the low pressure propane vapor regulators, Battelle adapted selected test procedures from the Underwriters Laboratory 144 *Standard for Safety for LP-Gas Regulators*. UL 144 is intended to establish the initial operating parameters of newly-manufactured regulators, as well as other performance specifications. The test procedures adapted for use were the Flow/Lock-up Tests (Section 21, Section 22, and Section 25.4) and Pressure Relief/Relief Capacity Tests (Section 23 and Section 24). According to this standard, first-stage regulators were expected to lock-up at pressures lower than 130% (for 100 psi and 25 psi inlet pressures) and 150% (for 250 psi inlet pressure) of the outlet set pressure. Second-stage, integral two-stage, and single-stage regulators were expected to lock-up at pressures lower than 120% (for 10 psi and 5 psi inlet pressures) and 160% (for 15 psi inlet pressure) of the outlet set pressure. The pressure relief devices were expected to start-to-discharge at a pressure between 140% and 250% of the outlet pressure for first-stage regulators and 170% to 300% of the outlet pressure for second-stage, single-stage, and integral two-stage regulators. In addition, the relief device was expected to reseal at a pressure greater than 140% of the outlet pressure for first-stage regulators and greater than 170% of the outlet pressure for second-stage, single-stage, and integral two-stage regulators.

² Ohm, Robert F., “The Vanderbilt Rubber Handbook -13th Edition”, R.T. Vanderbilt Company, Inc., 1990.

³ Rosato, Dominick V., “Rosato’s Plastics Encyclopedia and Dictionary”, Oxford University Press, 1993.

⁴ Southwest Research Institute, “Investigation of Portable or Handheld Devices for Detecting Contaminants in LPG, Docket 11296”, for the Propane Education and Research Council, Washington, D.C., 2005.

Of the over seven hundred regulators collected, a subset of 266 regulators was selected for testing based on statistical sampling methods. The 266 regulators were then subjected to external and internal inspections to identify any significant corrosion, damage, or missing components; lock-up testing at three different inlet pressures and four different flowrates; and pressure relief testing. A database of the test results was compiled and is provided in Volume 2. Included within the database are measurements of initial and adjusted outlet pressures; pressure-adjusting screw height before and after adjustment; outlet pressures during lock-up testing; start-to-discharge, reseal pressures, and flow rate during the pressure relief testing; and any leaks or other issues identified during testing. This has resulted in a comprehensive database that allows direct and detailed comparison of regulator performance.

The reason for regulator removal was not used as a selection criterion. However, 45 of the regulators had been labeled as “faulty” or “leaking through” by the submitters. Fifty-four tested regulators did not have the reason for removal identified by the submitters.

Age appears to have little effect on the performance of first-stage regulators, and only a slight effect on the performance of second-stage regulators. On the other hand, age appears to have a significant effect on the performance of single-stage regulators. Aside from the mechanical differences that provide the pressure control ranges of the three main types (first, second, and single-stage), these types have several components in common – flexible, elastomeric diaphragm, elastomeric seat disc, steel springs, and mechanical linkage. Degradation of the elastomers would affect all types of regulators. The single-stage unit must control over a much wider range of inlet pressures. This wide pressure-control requirement may make the single-stage units more susceptible to elastomer degradation and any corrosion on the metallic linkage parts.

Figure ES-1 shows the percentage of regulators that failed to meet the test criteria. As can be seen, these failure rates do not increase with statistical significance. This figure shows a large failure percentage for the age group of 55 to 60 years, however the sample set for this age group was one unit. A caution must be made about the failure rates presented in this report:

The rates presented here should not be construed as projected field failure rates. There are tens of millions of low pressure propane vapor regulators in the field, and failure rates of even ten percent would result in millions of failed units – this is clearly not the case. Rather, these failure rates are the result of an extremely rigorous test protocol that stresses the regulators to conditions not seen frequently in the field. Indeed, the particular combination of tests that were prescribed in the protocol may never be experienced in the field. The intent of the newly-developed testing criteria was to generate failures. These failure rates could then be compared between independent parameters of manufacturer, environment, and others. As shown in Figure ES-1, the rates are indeed significant. If the test were more representative of actual field conditions, several age groups would have had no failures, and others may have had only one failure. One could not compare these low failure rates.

The key observation here is that the currently used two-stage regulator systems show no significant degradation during the 20 to 25 year period of service that is now standard.

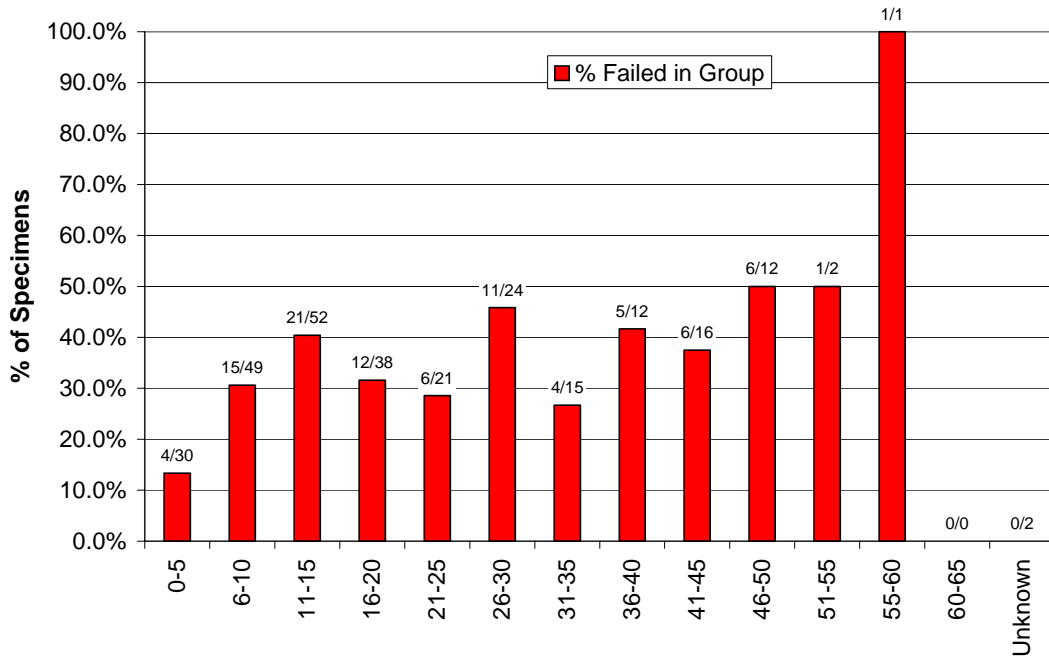

Figure ES-1. Regulator failures by age.

As previously mentioned, the numbers of regulators tested were fairly evenly distributed between two manufacturers, “A” and “B”, with over 125 of each manufacturer’s units tested. Figure ES-2 shows a summary of the failed regulators. Roughly 53 percent of the regulators tested were from Manufacturer A and approximately 47 percent were from Manufacturer B. Each of these showed similar range of results for lock-up, start-to-discharge, and reseal pressures. While more of the Manufacturer A regulators met the test criteria, this difference is fairly small.

These test data were replotted from the perspective of the four environmental regions:

- Warm; dry ($\geq 53^{\circ}\text{F}$; $< 73\%$ humidity),
- Warm; damp ($\geq 53^{\circ}\text{F}$; $\geq 73\%$ humidity),
- Cool; dry ($< 53^{\circ}\text{F}$; $< 73\%$ humidity), and
- Cool; damp ($< 53^{\circ}\text{F}$; $\geq 73\%$ humidity).

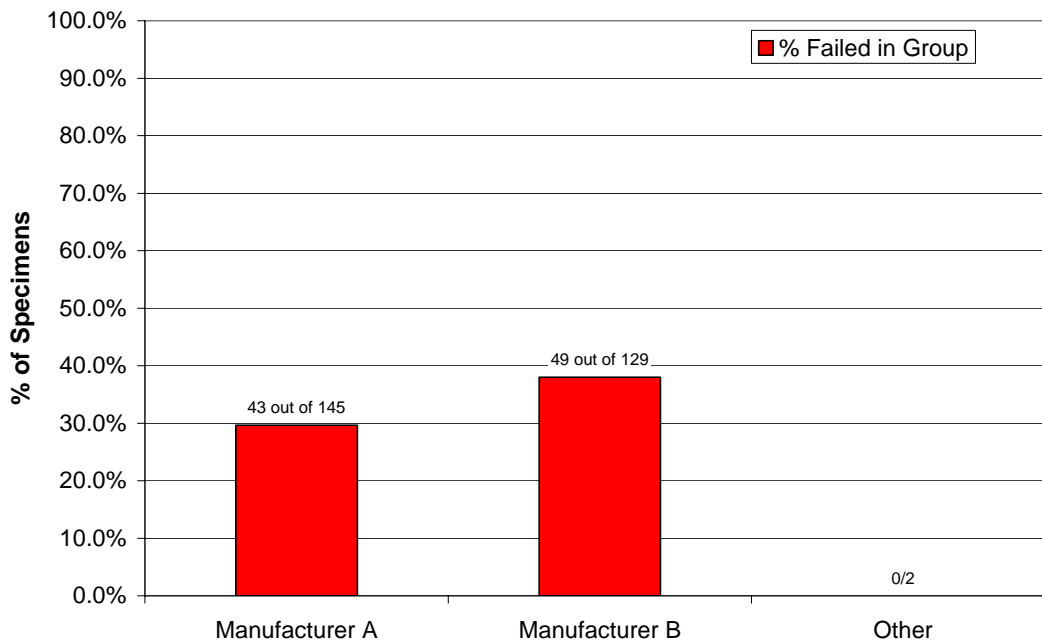

Figure ES-2. Regulator failures by regulator manufacturer.

Figure ES-3, which shows the number of failed regulators for the four environmental conditions, shows a higher percentage of failures from a warm, dry environment. With the number of samples being reasonably significant (much greater than ten units), the fact that nearly half of the warm, dry regulators failed to meet the test criteria is also significant. While internal and external corrosion may be considered a significant failure mechanism, drying or hardening of the elastomeric components may be more significant.

Several regulators that were identified as “failures” were selected for detailed failure analysis to determine possible failure mechanisms and environmental variables that contributed to the failure.

Findings from the failure analysis indicate a few possible trends as to why some regulators did not meet the test criteria. In particular, one second-stage regulator did not relieve because of excessive dirt and spider webs blocking the relief opening. This is not a manufacturing issue but rather a maintenance or installation issue and would not be indicative of any problems related to regulator age, environment, or manufacturer. This problem is not expected for regulators that are properly inspected and maintained.

For the regulators that were disassembled and analyzed, debris within the regulator body was the single most common potential cause for elevated regulator lock-up and/or leaks through the PRD. Some of the debris found appears to be corrosion products (from piping or containers), but other debris appears to be related to regulator manufacturing. For example, a first-stage regulator contained machining turnings inside the body of a regulator, with some pieces stuck on the

control disk seat. This debris was too large to get through the inlet screen of the regulator and appeared to be from the regulator manufacturing process.

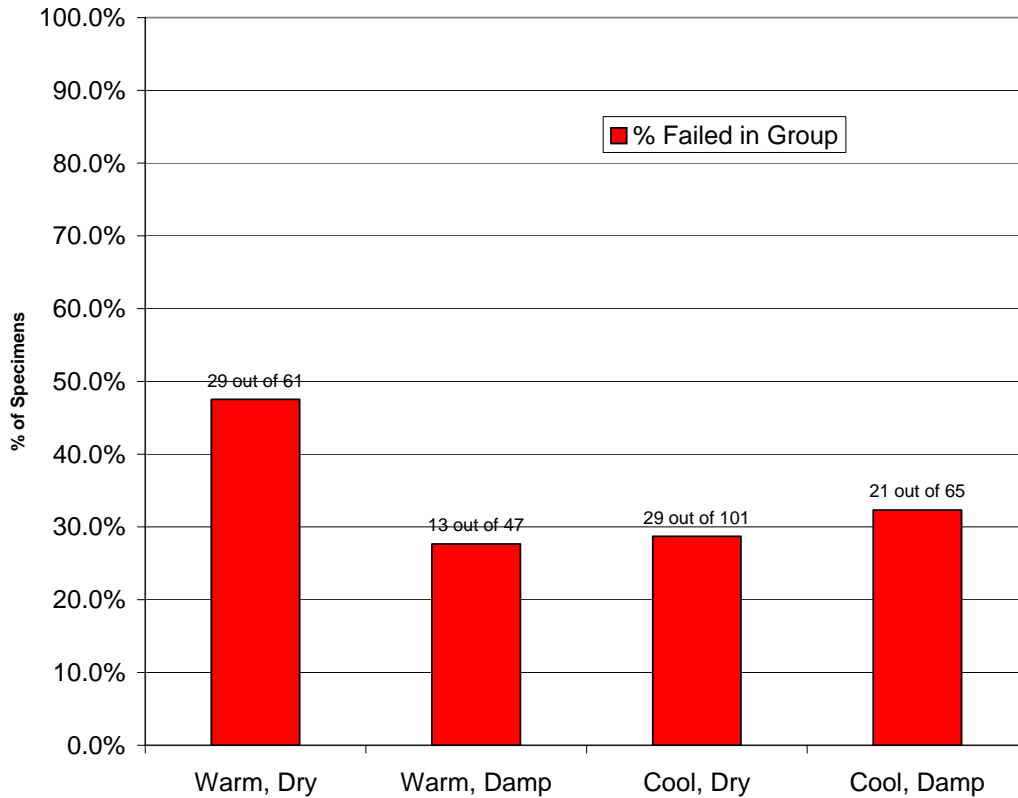

Figure ES-3. Regulator failures by regulator environment.

Other regulators showed some damage to the regulator seat disc which could have led to high lock-up pressures. For example, a single-stage regulator appeared to be in good condition during initial external and internal (visual through the bonnet opening) examinations. However, when examined more closely significant degradation of the seat disc was found. The seat disc appeared to have material losses more significant than what would be expected solely from the compression set. In addition, a significant amount of debris was found between the orifice and seat disc which could be attributed to the material lost from the seat disc. While this degradation is significant, this regulator was 43 years old when removed from service. This unit was in service well beyond the recommended service life of either the 15-year period or the more recent periods of 20 or 25 years.

For several other regulators no specific cause for the regulator “failure” could be determined. Possible causes included a slash on the diaphragm and a scratch on the regulator shaft that mates with the o-ring seal, however all other locations within the regulator body appeared to be in working order and free from significant debris.

Table of Contents

	Page
Acknowledgments.....	iii
Executive Summary	v
1.0 Program Objectives and Introduction	1
2.0 Background.....	3
2.1 How a Regulator Works.....	4
2.2 Types of Regulators	6
2.3 Propane Vapor Delivery System Configurations.....	7
3.0 Literature Review (GTI)	9
3.1 Approach.....	9
3.2 Literature Search Results	9
4.0 Regulator Gathering, Test Protocol Development, and Test Rig Design (Task 2).....	13
4.1 Gathering Regulator Samples	13
4.2 Development of Test Protocol	22
4.3 Design and Construction of Test Rig.....	27
5.0 Regulator Selection, Testing, and Evaluation (Task 2)	33
5.1 Regulator Selection.....	34
5.2 Visual Inspection of Regulators.....	37
5.2.1 Visual External Inspection.....	37
5.2.2 Visual Internal Inspection.....	37
5.2.3 Regulator Adjustment	38
5.3 Regulator Test Results and Evaluation.....	38
5.3.1 Summary of Lock-up Test Results	43
5.3.2 Summary of Pressure Relief Test Results.....	57
5.3.3 Effects of Manufacturer on Regulator Performance	69
5.3.4 Effects of Environment on Regulator Performance.....	74
5.3.5 Causes of Regulator “Failures”.....	80
6.0 Inspections of “Failed” Regulators (Task 3).....	91
7.0 Conclusions.....	95
7.1 Literature Survey	95
7.2 Effects of Age on Regulator Performance	96
7.3 Effects of Manufacturer on Regulator Performance.....	97
7.4 Effects of Environment on Regulator Performance.....	97
7.5 Inspections of “Failed” Regulators	97

APPENDICES

Appendix A – Literature Review of Low Pressure Propane Vapor Regulators by GTI.....	A-1
Appendix B – Comments on Regulator Test Protocol and Associated Justification for the Revised Protocol	B-1
Appendix C – Inspections of “Failed” Regulators.....	C-1

List of Tables

	Page
Table 1. Types of propane regulators.	6
Table 2. Number and location of regulators received for the study.....	15
Table 3. Overview of first-stage regulator performance.....	39
Table 4. Overview of second-stage regulator performance.....	40
Table 5. Overview of integral two-stage regulator performance.....	41
Table 6. Overview of single-stage regulator performance.....	41
Table 7. First-stage regulators that did not meet the UL 144 lock-up criteria for new regulators.....	44
Table 8. Second-stage regulators that did not meet the UL 144 lock-up criteria for new regulators.....	49
Table 9. Integral two-stage regulators that did not meet the UL 144 lock-up criteria for new regulators.....	52
Table 10. Single-stage regulators that did not meet the UL 144 lock-up criteria for new regulators.....	55
Table 11. First-stage regulators that did not meet the UL 144 PRD criteria for new regulators..	58
Table 12. Second-stage regulators that did not meet the UL 144 PRD criteria for new regulators.	64
Table 13. Integral two-stage regulators that did not meet the UL 144 PRD criteria for new regulators.....	65
Table 14. Single-stage regulators that did not meet the UL 144 PRD criteria for new regulators.....	67
Table 15. Summary table of failed regulators.....	83
Table 16. Regulator failures by type.....	85
Table 17. Regulator failures by manufacturer.	86
Table 18. Regulator failures by age.	87
Table 19. Regulator failures by environmental condition.	88
Table 20. Regulators selected for failure analysis.	91

List of Figures

	Page
Figure ES-1. Regulator failures by age.....	viii
Figure ES-2. Regulator failures by regulator manufacturer.....	ix
Figure ES-3. Regulator failures by regulator environment.....	x
Figure 1. Components of a typical regulator.	3
Figure 2. Positive back pressure regulator.....	5
Figure 3. Pressure/flowrate chart.....	5
Figure 4. Two-stage system with relief in first-stage regulator.....	8
Figure 5. Two-stage system with separate relief valve on supply line.....	8
Figure 6. Map illustrating climate regions and source locations of collected regulators.	16
Figure 7. Age distribution of test regulators.	16
Figure 8. Source environments of test regulators.	17
Figure 9. Source locations of test regulators.....	17
Figure 10. Type distribution of test regulators.....	18
Figure 11. Manufacturer distribution of test regulators.....	18

Figure 12. Tag lacking information.	20
Figure 13. Tag with sufficient information.	21
Figure 14. Regulator test protocol.	24
Figure 15. Regulator test rig schematic.	28
Figure 16. Regulator test stand — front view.	29
Figure 17. Regulator test stand — rear view.	29
Figure 18. Compressor for test air supply.	30
Figure 19. Regulator datasheet.	31
Figure 20. Average and 95% upper confidence bounds for first-stage regulators with 100 psi inlet pressure.	36
Figure 21. Average and 95% upper confidence bounds for second-stage regulators with 10 psi inlet pressure.	36
Figure 22. Lock-up pressures and age for 10 psi first-stage regulators at 100 psig inlet pressure.	44
Figure 23. Lock-up pressures and age for 10 psi first-stage regulators at 25 psig inlet pressure.	45
Figure 24. Lock-up pressures and age for 10 psi first-stage regulators at 250 psig inlet pressure.	45
Figure 25. Lock-up pressures and age for 5 psi first-stage regulators at 100 psig inlet pressure.	46
Figure 26. Lock-up pressures and age for 5 psi first-stage regulators at 25 psig inlet pressure.	46
Figure 27. Lock-up pressures and age for 5 psi first-stage regulators at 250 psig inlet pressure.	47
Figure 28. Lock-up pressures and age for 15 psi first-stage regulators at 100 psig inlet pressure.	47
Figure 29. Lock-up pressures and age for 15 psi first-stage regulators at 25 psig inlet pressure.	48
Figure 30. Lock-up pressures and age for 15 psi first-stage regulators at 250 psig inlet pressure.	48
Figure 31. Lock-up pressures and age for second-stage regulators at 10 psig inlet pressure.	50
Figure 32. Lock-up pressures and age for second-stage regulators at 5 psig inlet pressure.	50
Figure 33. Lock-up pressures and age for second-stage regulators at 15 psig inlet pressure.	51
Figure 34. Lock-up pressures and age for integral two-stage regulators at 100 psig inlet pressure.	52
Figure 35. Lock-up pressures and age for integral two-stage regulators at 25 psig inlet pressure.	53
Figure 36. Lock-up pressures and age for integral two-stage regulators at 250 psig inlet pressure.	53
Figure 37. Lock-up pressures and age for single-stage regulators at 100 psig inlet pressure.	56
Figure 38. Lock-up pressures and age for single-stage regulators at 25 psig inlet pressure.	56
Figure 39. Lock-up pressures and age for single-stage regulators at 250 psig inlet pressure.	57
Figure 40. Start-to-discharge pressures and age for 10 psi first-stage regulators.	59
Figure 41. Reseat pressures and age for 10 psi first-stage regulators.	59
Figure 42. Start-to-discharge pressures and age for 5 psi first-stage regulators.	60
Figure 43. Reseat pressures and age for 5 psi first-stage regulators.	60
Figure 44. Start-to-discharge pressures and age for 15 psi first-stage regulators.	61

Figure 45. Reseat pressures and age for 15 psi first-stage regulators.....	61
Figure 46. Start-to-discharge pressures and age for second-stage regulators.....	62
Figure 47. Reseat pressures and age for second-stage regulators.....	63
Figure 48. Start-to-discharge pressures and age for integral two-stage regulators.....	66
Figure 49. Reseat pressures and age for integral two-stage regulators.....	66
Figure 50. Start-to-discharge pressures and age for single-stage regulators.....	68
Figure 51. Reseat pressures and age for single-stage regulators.....	68
Figure 52. Lock-up pressures and manufacturer for 10 psi first-stage regulators at 100 psig inlet pressure.....	69
Figure 53. Start-to-discharge pressures and manufacturer for 10 psi first-stage regulators.....	70
Figure 54. Reseat pressures and manufacturer for 10 psi first-stage regulators.....	70
Figure 55. Lock-up pressures and manufacturer for second-stage regulators at 10 psig inlet pressure.....	71
Figure 56. Start-to-discharge pressures and manufacturer for second-stage regulators.....	71
Figure 57. Reseat pressures and manufacturer for second-stage regulators.....	72
Figure 58. Lock-up pressures and manufacturer for single-stage regulators at 100 psig inlet pressure.....	72
Figure 59. Start-to-discharge pressures and manufacturer for single-stage regulators.....	73
Figure 60. Reseat pressures and age for single-stage regulators.....	73
Figure 61. Regulator failures by regulator manufacturer.....	74
Figure 62. Lock-up pressures and environment for 10 psi first-stage regulators at 100 psig inlet pressure.....	75
Figure 63. Start-to-discharge pressures and environment for 10 psi first-stage regulators.....	76
Figure 64. Reseat pressures and environment for 10 psi first-stage regulators.....	76
Figure 65. Lock-up pressures and environment for second-stage regulators at 10 psig inlet pressure.....	77
Figure 66. Start-to-discharge pressures and environment for second-stage regulators.....	77
Figure 67. Reseat pressures and environment for second-stage regulators.....	78
Figure 68. Lock-up pressures and environment for single-stage regulators at 100 psig inlet pressure.....	78
Figure 69. Start-to-discharge pressures and environment for single-stage regulators.....	79
Figure 70. Reseat pressures and age for single-stage regulators.....	79
Figure 71. Regulator failures by regulator environment.....	80
Figure 73. Regulator “failures” by type of regulator.....	85
Figure 73. Regulator “failures” by regulator manufacturer.....	86
Figure 74. Regulator “failures” by regulator age.....	87
Figure 75. Regulator “failures” by type of environment.....	88
Figure 76. Regulator 711 — blocked pressure relief.....	92
Figure 77. Regulator 571 — machining turnings found inside regulator.....	92
Figure 78. Regulator 383 — seat disc.....	93

Terms and Acronyms

Btu	British thermal unit
cfh	cubic feet per hour
cfm	cubic feet per minute
DOT	United States Department of Transportation
in wc	inches of water column
NFPA	National Fire Protection Association
NPGA	National Propane Gas Association
PERC	Propane Education & Research Council
PRD	pressure relief device
psi	pound per square inch
UL	Underwriters Laboratories

This page intentionally left blank.

1.0 PROGRAM OBJECTIVES AND INTRODUCTION

Anecdotal evidence suggests that the natural gas industry effectively and safely uses low pressure regulators in field service for time periods exceeding 30 years. Yet in the LP gas (propane)* industry, regulator manufacturers provide regulators that have limited field evaluation capability and regularly carry a 15-year replacement recommendation.

Recently, three propane regulator manufacturers have extended the service-life recommendation of some propane regulators. For example, ECII/RegO® and Sherwood literature recommends a service life of 25 years for first- and second-stage regulators manufactured after 1995 and a recommended service life of 15 years for all other regulators. Catalogs from Fisher recommend regulator replacement at 20 years. Fisher also recommends replacing any regulators “that have experienced conditions (corrosion, underground systems, flooding, etc.) that would shorten their service life.” The Propane Education & Research Council (PERC) is interested in determining whether there is scientific or engineering support for the 15-year replacement recommendation, as well as for the recently extended service life recommendation for some models. PERC requested Battelle’s assistance in developing data and analyses to better understand the performance of in service low pressure propane vapor regulators.

The objectives of this program are to evaluate the performance, durability, and service life of low pressure propane vapor regulators through the following tasks:

- Task 1. Review and summarize current US, European, Australian, and Japanese propane regulator manufacturer’s literature on recommended service life and the basis for all service life recommendations;
- Task 2. Gather and test first- and second-stage regulators pulled from service to identify if they exhibit catastrophic failure modes that could result in potential safety problems; and
- Task 3. Inspection of selected regulators that failed one or more test criteria.

This report summarizes the results of an experimental program in which low pressure propane vapor regulators ranging in age from 1 to over 50 years were collected from across the United States and were subjected to a series of tests intended to characterize their performance. This is Volume 1 of a two volume report on the results of the program. This first volume is a summary and analysis of the test results. The second volume provides a detailed description of the results of each regulator investigated, including the test datasheets and photos. Volume 1 is organized as follows:

- Background
- Literature Review
- Overview of Regulator Collection, Test Protocol Development, and Test Rig Design
- Regulator Selection, Testing, and Evaluation
- Inspection of Failed Regulators

* The terms “LP gas” and “propane” are used interchangeably in the industry and this report.

- Appendix A – GTI Literature Review
- Appendix B – Comments on Regulator Test Protocol Development
- Appendix C – Inspections of “Failed” Regulators.

The summary and conclusions of this program are provided in the Executive Summary at the beginning of the document.

2.0 BACKGROUND

Propane regulators are designed to reduce gas supply pressures to a desired operating pressure range. Systems installed today consist of two-stage regulation in which a first-stage regulator reduces supply pressure to near 10 psig, and a second-stage regulator further reduces the pressure to typical appliance pressures, nominal 11 inches of water column (in wc). This two-stage system can also be combined into one regulator known as an integral two-stage regulator. All LP gas regulators are installed according to the National Fuel Gas Code (NFPA 54), Standard for the Storage and Handling of Liquefied Petroleum Gases Code (NFPA 58), and any local requirements.

Components of a typical regulator are shown in Figure 1.



Figure 1. Components of a typical regulator.¹

Selection of regulators is based on the desired gas supply pressure as well as the flow capacity (defined in Btu/hr) required by the total gas load. Regulators are rated at the amount of Btu/hour they can deliver at a specific inlet and outlet pressure. If a regulator will supply multiple appliances, the Btu requirements for each appliance are added to identify the regulator capacity necessary for that particular application. Flow capacity tables and charts are provided by the regulator manufacturers to aid in this selection process.

¹ From USDOT/PHMSA Office of Pipeline Safety Chapter IX http://ops.dot.gov/regs/small_lp/Chapter9.htm

To achieve the desired outlet pressures, many regulators can be adjusted to the specified set point for that system. In adjustable regulators, the outlet pressures can be changed by removing the bonnet cap and adjusting the screw found inside. Some regulators are factory set to the specified outlet pressure and therefore cannot be re-adjusted by the marketer or consumer.

Underwriters Laboratories Standard UL 144 is the listing document for construction and performance of LP-Gas Regulators. UL 144 defines temperature/pressure ratings, relief valve performance, materials of construction, lock-up ranges, adjustment range, operation/performance and marking requirements. This standard was used as the basis for this test program.

2.1 How a Regulator Works

The low pressure LP gas regulators are positive back pressure regulators used for first-stage, second-stage, single-stage, and integral two-stage regulation. The positive back pressure regulator provides good flow characteristics over a wide range of inlet pressures. The regulator delivery pressure is affected by the changes in inlet pressure, as well as demand from a downstream appliance(s). The seat disc is on the downstream side of the seat. As inlet pressure rises, the delivery pressure rises; as inlet pressure drops, delivery pressure drops.

Figure 2 illustrates the basic components related to how a regulator works, with the following text from the DOT website referenced below¹.

Gas enters through the inlet and flows through an orifice (A). As pressure builds under the diaphragm (B), which moves upward and pushes the seat disc attached to the lever assembly (D) against the inlet nozzle or orifice (A). At the same time adjusting spring (C) compresses, limiting the travel of the diaphragm. If there is no gas demand, the seat disc will stay against the nozzle and gas flow will stop. This is called lock-up. Lock-up outlet pressures are always greater than the set point pressure as illustrated in Figure 3. When gas demand from the appliance begins, pressure under the diaphragm (B) is reduced, the adjustment spring pushes the lever/seat disc away from the seat and gas flow is allowed through the seat. The diaphragm will continue to sense the pressure under it, and will compress or relax the adjustment spring, which will move the seat lever/seat disc assembly against or away from the seat. This constant movement controls the pressure to downstream regulators or appliances. The design of the adjustment spring determines the pressure setting.

¹ From US DOT/PHMSA Office of Pipeline Safety Chapter IX http://ops.dot.gov/regs/small_lp/Chapter9.htm

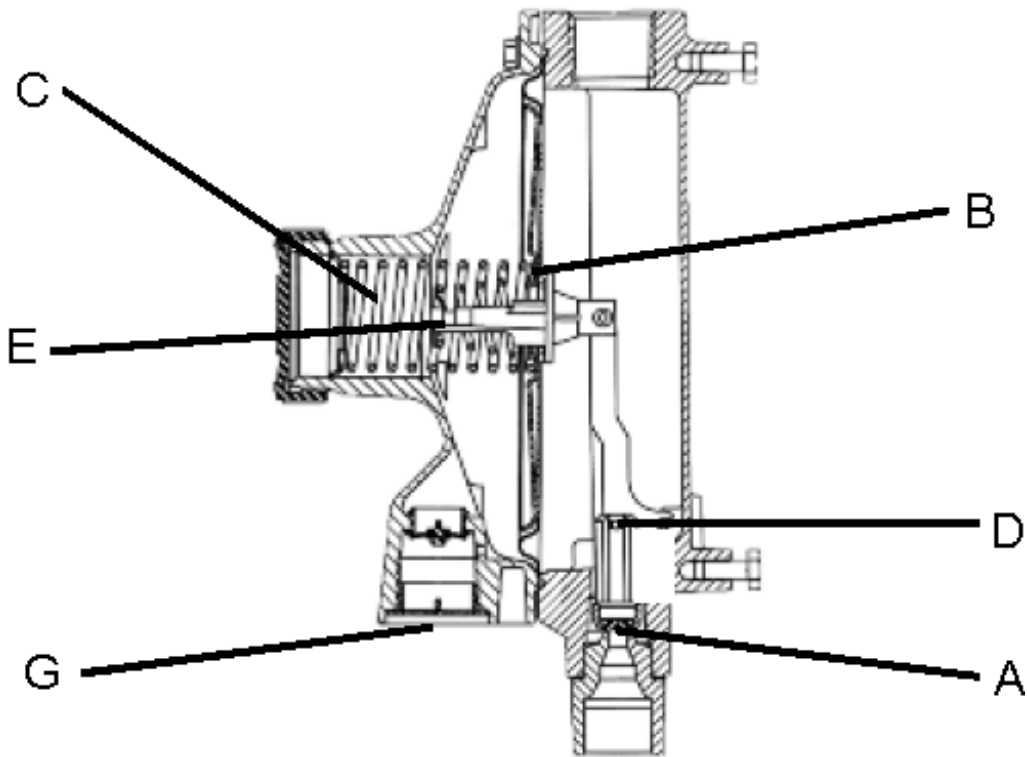

Figure 2. Positive back pressure regulator.¹

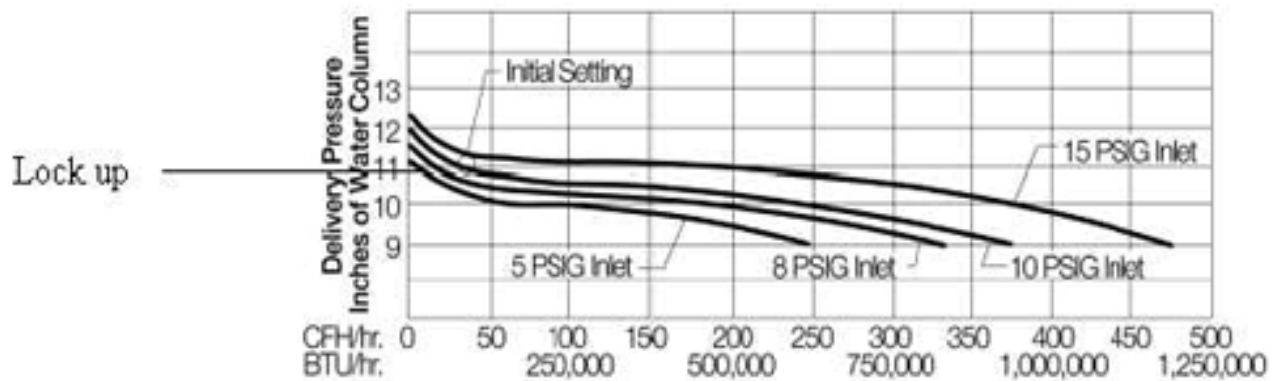

Figure 3. Pressure/flowrate chart.²

¹ From US DOT/PHMSA Office of Pipeline Safety Chapter IX http://ops.dot.gov/regs/small_lp/Chapter9.htm

² From US DOT/PHMSA Office of Pipeline Safety Chapter IX http://ops.dot.gov/regs/small_lp/Chapter9.htm

Relief Operation

A relief valve is installed in all second- and integral two-stage regulators and most first-stage regulators. The relief valve is designed to protect downstream equipment and appliances from overpressure and operates according to UL 144 requirements. Relief valve operation is described on the DOT website, referenced below with the following text from the DOT website referenced below¹.

When gas enters through orifice (A), as described in Figure 2 and downstream demand is reduced or stops, the lever/seat disc (D) will move toward the nozzle to the lock-up position. If the regulator seat disc cannot fully contact the orifice (A), pressure will continue to build until diaphragm (B) moves up to the point where relief spring (E) begins to compress, allowing gas flow through the relief area into the bonnet and out through the vent (G). The relief valve will automatically close once the pressure under the diaphragm is reduced to a nominal pressure.



2.2 Types of Regulators

Regulator systems control gas pressure from the container to the appliance, reducing the container pressure to the required outlet pressure. There are several types of regulators that can be used to achieve the desired system performance and range in style and combinations of regulators and are presented in Table 1.

Table 1. Types of propane regulators.

Regulator Type	Description	Example
Single-stage	<ul style="list-style-type: none">• A single regulator mounted on the propane container with a line running directly to the appliance(s)• Limited to small portable appliances and outdoor cooking appliances with maximum input ratings of 100,000 Btu/hr per NFPA 58, 1995 Edition.• Designed for propane vapor service to reduce container pressure to 1.0 psig or less (typically 11 in wc)• Listed by Underwriters Laboratories or equivalent for use in propane with an inlet pressure rating of 250 psig.• Utilizes a type I relief valve which has a limited capacity; operating range is from 18.7 in to 33 in wc• Per the 1995 Edition of NFPA 58, single-stage regulators may no longer be installed on fixed piping systems.	

¹ From US DOT/PHMSA Office of Pipeline Safety Chapter IX http://ops.dot.gov/regs/small_lp/Chapter9.htm

Regulator Type	Description	Example
<p>First-Stage</p>	<ul style="list-style-type: none"> • A pressure regulator for propane vapor service designed to reduce container pressure to 5, 10, 15, or 20 psig (typically 10 psig). • Used as the container regulator in a two-stage system. • This regulator is UL listed for use as a first-stage regulator with an inlet pressure rating of 250 psig. • This regulator utilizes a type I relief valve which is a limited capacity; operating range is from 14 psig to 25 psig. 	
<p>Second-Stage</p>	<ul style="list-style-type: none"> • A pressure regulator for propane vapor service designed to reduce first-stage regulator outlet pressure to 14" water column or less (typically 11 in wc) • This regulator is UL listed for use in propane with an inlet pressure marked at 10 psig, but a rating of 250 psig. • This regulator utilizes a type II relief valve - a high capacity type for final stage regulators; operating range is from 18.7 in to 33 in wc 	
<p>Integral Two-Stage</p>	<ul style="list-style-type: none"> • A pressure regulator that combines both a high pressure and a second-stage regulator into a single unit. • UL listed with a 250 psig inlet pressure rating, no relief in the first-stage section and a type II relief valve in the second-stage section. 	

2.3 Propane Vapor Delivery System Configurations

Prior to 1995, many propane systems utilized one single-stage regulator to reduce container pressures to appliance pressures of 11 in wc. However, in the event of regulator failure it was possible for appliances to see container pressures. To enhance the safety of propane systems, two-stage regulation was mandated in the 1995 Edition of NFPA 58. According to this edition of NFPA 58, all new domestic fixed pipe installations must use either a two-stage system or an integral two-stage regulator. Single-stage regulators may no longer be installed on these systems. To assist in phasing out single-stage regulation systems, there are ongoing state programs that provide rebates to local marketers for removing single-stage regulation systems and replacing with two-stage regulation.

A two-stage propane vapor delivery system combines a first-stage regulator and second-stage regulator, integral two-stage regulator, or an automatic changeover regulator. In propane systems rated for less than 500,000 Btu/hr, the first-stage regulators typically have an integral relief valve as shown in Figure 4.

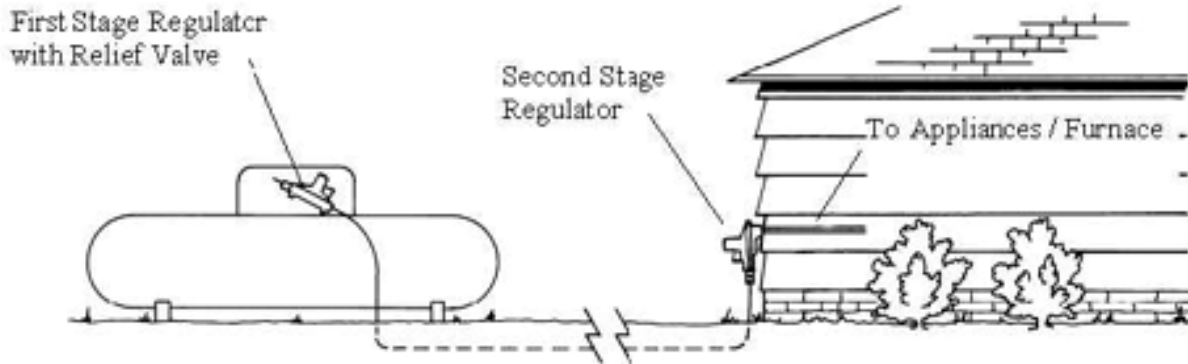

Figure 4. Two-stage system with relief in first-stage regulator.¹

Two-stage regulator systems with a first-stage regulator rated at more than 500,000 BTU/HR set at 10 psig or less, typically do not have an integral relief valve. In this case the first-stage regulator is permitted to have a separate relief valve. It must operate within specified start-to-discharge limits of UL 144 (140%-250%) of the regulator set pressure. The second-stage will supply the required appliance pressure. This type of system is depicted in Figure 5.

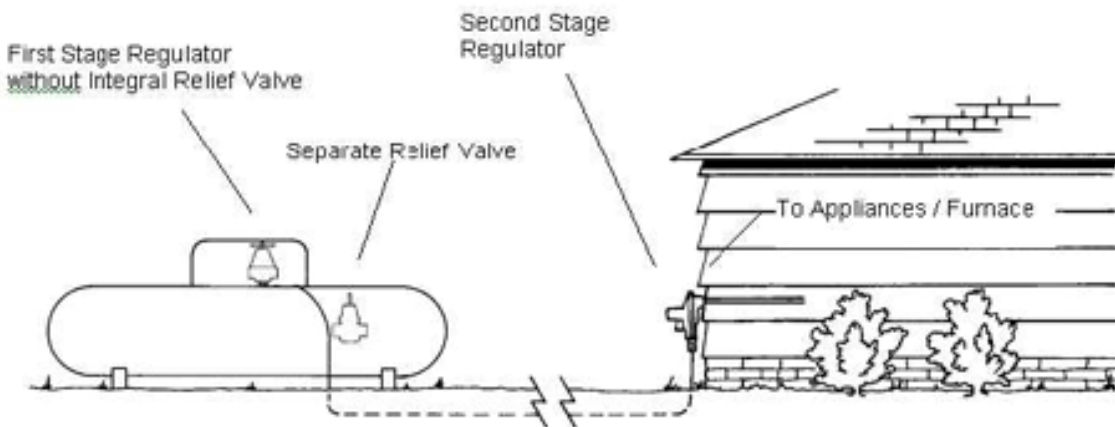

Figure 5. Two-stage system with separate relief valve on supply line.²

¹ From US DOT/PHMSA Office of Pipeline Safety Chapter IX http://ops.dot.gov/regs/small_lp/Chapter9.htm

² From US DOT/PHMSA Office of Pipeline Safety Chapter IX http://ops.dot.gov/regs/small_lp/Chapter9.htm

3.0 LITERATURE REVIEW (GTI)

With the recently extended service-life recommendation of some propane regulators, a literature review was important to determine if there was scientific or engineering support for a 15-year replacement recommendation, and if an extended service life recommendation for some models was warranted.

The objective was to provide an annotated review of available information worldwide on low-pressure propane regulators with focus on recommended service life and to the extent possible the basis for cited recommendations.

3.1 Approach

U.S. manufacturers market low-pressure propane regulators worldwide. These regulators are constructed to comply with U.S. standards and then separately certified for use in overseas markets. For this reason, the focus of this review was on U.S. manufacturers, specifically the three companies that occupy a majority of the regulator market share: Fisher, RegO[®], and Sherwood.

GTI reviewed manufacturers' literature from Fisher, RegO[®], and Sherwood and concentrated on additional research conducted by the Korean Gas Safety Corporation. In addition, GTI reviewed relevant codes and standards, and reviewed the abstracts of peer-reviewed research on materials. GTI supplemented this review with follow-up discussion with materials and analytical personnel, and with the regulator manufacturers.

3.2 Literature Search Results

The areas of focus of the literature search included elastomers, metals, propane composition, codes and standards, manufacturer's literature, and missing data. The complete GTI report is provided in Appendix A. This section highlights the findings of GTI's literature search.

- **The literature review was not able to document scientific or engineering support for a service-life recommendation of 15 years or greater.** The findings of the literature review suggest further research in the use and variability of plasticizers and extenders in the rubber composition of propane regulator components; the long-term effect a propane operating environment has on elastomer and spring performance; and the effect of propane contaminants and off-specification gas on U.S. propane regulator performance.
- In "Aging Characteristics of Low Pressure LPG Regulators for Domestic Use"¹, results showed that in general the safety devices of the low-pressure regulators deviated from like-new operation after a year of service and deviated from the discharge start and reset

¹ Jeong-Rock Kwon, Young-Gyu Kim Gas Safety R&D Center, Korea Gas Safety Corporation, "Aging Characteristics of Low Pressure LPG Regulators for Domestic Use", May 1999.

pressures of the new regulators. Overall, the operating and closing pressures also deviated from the pressure range of the new regulators after a year of service. A 6-year service life was determined:

- Testing of diaphragms from the propane regulators in the field found a loss of tensile strength and decreased range of motion after 5 years of service. Researchers suspect a hardening of the diaphragms due to leaching of plasticizers from rubber materials over time. The authors called for further research to improve diaphragm durability and reliability, to investigate the effect of plasticizer extraction from rubber materials on diaphragm performance, and the development of new rubber materials with improved rubber characteristics and properties.
 - Testing of propane regulator springs from the field found a loss in tensile strength after a 7 year service life. The authors called for research on various aspects of springs, including the surface treatment on the ending parts of the spring, quality control in the manufacturing, and reinforcement of durability characteristics.
 - None of the regulators tested were from U.S. manufacturers. Research is warranted to investigate the long-term effect a propane operating environment has on elastomer and spring performance.
- A review of elastomers reference literature, “The Vanderbilt Rubber Handbook -13th Edition”¹, and “Rosato’s Plastics Encyclopedia and Dictionary”², found that additives, particularly plasticizers and extenders, can leach out over time, resulting in physical changes in size, elongation, and tear strength. In regulators, elastomers are used in valve seat discs and diaphragms. Research is warranted to assess the use and variability of plasticizers and extenders in the rubber composition of propane regulator components.
 - In “Investigation of Portable or Handheld Devices for Detecting Contaminants”³, findings indicate that while propane for domestic use meets commercial grade specifications, contamination occurs in small quantities in the supply chain over time. Further, the impact of propane contaminants and off-specification gas is not well documented. Research is warranted to investigate the effect of propane contaminants and off-specification gas on U.S. propane regulator performance.
 - **Underwriters Laboratories’ UL 144 LP-Gas Regulators is the current performance standard for LP-Gas regulators and is designed for new regulators, not regulators that have been in the field.** UL 144 does not address the issue of service or useful life. Test requirements for materials such as elastomers are also found in UL 144. Tests include propane compatibility (with n-hexane as the test fluid), accelerated aging (in heated air), and low temperature exposure (in cooled air). UL 144 does not give references on using n-hexane as a surrogate for propane. UL 144 does not address the varying composition of propane, therefore the effect of off-specification propane or even the broad range of on-specification compositions is unknown.

¹ Ohm, Robert F., “The Vanderbilt Rubber Handbook -13th Edition”, R.T. Vanderbilt Company, Inc., 1990.

² Rosato, Dominick V., “Rosato’s Plastics Encyclopedia and Dictionary”, Oxford University Press, 1993.

³ Southwest Research Institute, “Investigation of Portable or Handheld Devices for Detecting Contaminants in LPG, Docket 11296”, for the Propane Education and Research Council, Washington, D.C., 2005.

- Codes and standards that reference UL 144, including NFPA 54: National Fuel Gas Code, NFPA 58: Liquid Petroleum Gas Code and ANSI Z21.18a-2001/CSA 6.3a Gas Appliance Pressure Regulators do not address useful or service life of propane system components.
- A review of U.S. manufacturers' literature found:
 - RegO[®] recommends regulator service life of 25 years for regulators (except single-stage) manufactured after 1995; all other regulators have a recommended service life of 15 years.
 - Fisher recommends regulator replacement at 20 years, or over 15 years of age for regulators that have experienced conditions (corrosion, underground systems, flooding, etc.) that would shorten their service life.
 - Sherwood recommends regulator replacement after 15 years; however, Sherwood has recently posted a statement on their website that now recommends a 25-year life on some models¹.
- Typical materials identified in the literature that are used in propane regulators include zinc or die cast aluminum bodies, chromate coatings, nitrile rubber and other synthetic polymers, and stainless steel springs.
- Service life attributes, or manufacturers' stated features that influence service life, include a corrosion resistant relief valve seat (Fisher); stainless steel relief valve spring and retainer (Fisher); and painted, heavy-duty zinc (body and bonnet) resists corrosion and gives long-life protection, even under "salty air" conditions. (RegO[®]).
- All three manufacturers' literature reference National Propane Gas Association (NPGA) documents in discussions related to installation, inspection, maintenance, and safety. NPGA no longer supports these documents and has released these documents to the public domain provided that they are not attributed to NPGA. Discontinued documents that are referenced include:
 - NPGA Installation and Service Guide Book #4003,
 - NPGA Propane Safety and Technical Support Manual Bulletin T403,
 - NPGA Safety Pamphlet 306 "LP-Gas Regulator and Valve Inspection and Maintenance",
 - NPGA LPG Safety Handbook #0001, and
 - NPGA Bulletin #133-80.

These documents can no longer be referenced as NPGA documents and efforts should be made by the manufacturers to acknowledge and correct this within their product literature.

¹ http://www.sherwoodvalve.com/products.htm/Regulator_25_YR_Ser_Life_Rev_2_3-25-04.pdf

This page intentionally left blank.

4.0 REGULATOR GATHERING, TEST PROTOCOL DEVELOPMENT, AND TEST RIG DESIGN (TASK 2)

Propane gas regulator replacement requirements are based upon assumptions of the severity of the service environment and how much damage is caused by the service environment. However, without a systematic evaluation of regulators from service, there has been no way to know if these assumptions are valid or how conservative the requirements are. The underlying goal of this program was to collect a large set of regulators representing a variety of ages, types, manufacturers, service environments and service conditions and to test them to better understand real world performance and the scientific merit behind the regulator replacement requirements.

This goal was accomplished by collecting regulators of various ages, makes, and models that have been in service across the United States and subjecting the regulators to a series of tests based on UL 144 that demonstrate their performance. This section of the report gives a brief summary of the collection process, test protocol development, and test rig design. It is followed by an in-depth review of regulator test results and observations.

To successfully complete the low pressure propane regulator performance testing program the primary goals were to:

1. Gather a statistically valid sample of first-and second-stage regulators (various ages, makes, models, and regional/environmental conditions) for performance testing.
2. Develop a test protocol valid for regulators that have been recently removed from service and gather feedback from industry members on this protocol.
3. Design and construct a test rig to conduct the regulator performance testing.
4. Tabulate performance test data in a data base and analyze data to assist in the determination of expected regulator service life. Trends were examined between various geographic locations, regulator ages, and manufacturers.

All of these goals are discussed further in the subsequent sections of this report.

4.1 Gathering Regulator Samples

Efforts were made to obtain a reasonable age, type, and manufacturer distribution of residential low pressure propane vapor regulators from a range of environmental conditions typical of the United States. Battelle worked with the NPGA, PERC, state propane associations, and industry consultant Larry Osgood to acquire over 700 regulators from propane marketers located throughout the United States. Announcements were placed in weekly NPGA newsletters and PERC weekly email newsletters detailing project requirements and contact information. In addition, the project background and needs were presented to members at the NPGA Technology and Standards Committee November 2004 meeting.

Battelle also contacted a majority of the state propane associations and over 450 individual propane marketers across the country via telephone and email to request their participation in this study. Propane marketers were requested to provide regulators from different manufacturers, ages, service uses (residential and commercial), environmental conditions, and makes/models of regulators that recently been removed from service (within one month of shipping to Battelle). The requirement that the regulators be recently removed from service was to reduce the possibility that a regulator was affected by the internals being exposed to air for extended periods of time. Regulators could have been removed from service for a variety of reasons: failure of the regulator to perform, change or loss of customer account, end of recommended service life. Marketers interested in participating were sent shipping supplies consisting of large, plastic zip-lock bags and information tags. The information tags requested the following information:

- Submittal Date
- Contact Information
- Regulator Manufacturer
- Model Number
- Regulator Type
- Year Installed
- Date Removed from Service (must be within the past month)
- Regulator Location
- Geographic Service Area
- Reason for Regulator Removal
- General Regulator Operating Conditions (location at tank; location at building; types of appliances within household)

Battelle asked that the marketers fill out an information tag for each regulator and attach it to the regulator prior to shipping. From this effort we received a good response; approximately 80 different propane marketers across the country promising to provide over 1000 regulators. A total of 773 regulators were received for evaluation in this program. The 773 regulators were supplied by 49 different marketers in 27 different states, with a large majority (~56%) coming from South Dakota, Mississippi, and Iowa. The list of states and the number of regulators provided from each state is provided in Table 2. The collection of the regulators encompassed the following conditions and environments

- 1 to 50+ years in age
- 4 different service environments
- 27 different source locations
- 4+ different regulator manufacturers
- 4 types of regulators

The collection effort specifically targeted first-stage, second-stage, and integral two-stage regulators to examine the assumptions behind the 15-year replacement recommendations. A sampling of single-stage regulators was also collected and tested; however, since 1995 these

regulators have not been allowed to be placed into service and therefore the testing efforts did not focus on their performance.

Table 2. Number and location of regulators received for the study.

State	# of Regulators Received
AK	17
AL	1
AZ	4
CA	14
CO	5
FL	10
IA	162
IL	3
IN	32
KS	5
KY	6
MA	2
ME	18
MI	19
MO	2
MS	87
NC	15
NH	10
NJ	12
NY	21
OH	8
PA	27
SC	47
SD	184
VA	33
WA	23
WI	4
Unknown	2
Total	773

Figure 6 illustrates the different states and four environmental regions from which regulators were collected. As such, it provides a good basis for examining some of the assumptions that are the foundation for the service life of low pressure propane vapor regulators.

Figures 7 through 11 summarize the characteristics and subsets of the regulators which were selected for detailed testing and evaluation. Figure 7 compares the ages of the regulator test population. The majority of the regulators collected and tested ranged in age from 5 to 20 years, although a few regulators over 50 years old were tested. Thirty of the regulators tested were 5 years old or less, another 49 of the regulators tested were between 5 and 10 years old, 52 were between 10 and 15 years old, and 38 were between 15 and 20 years old.

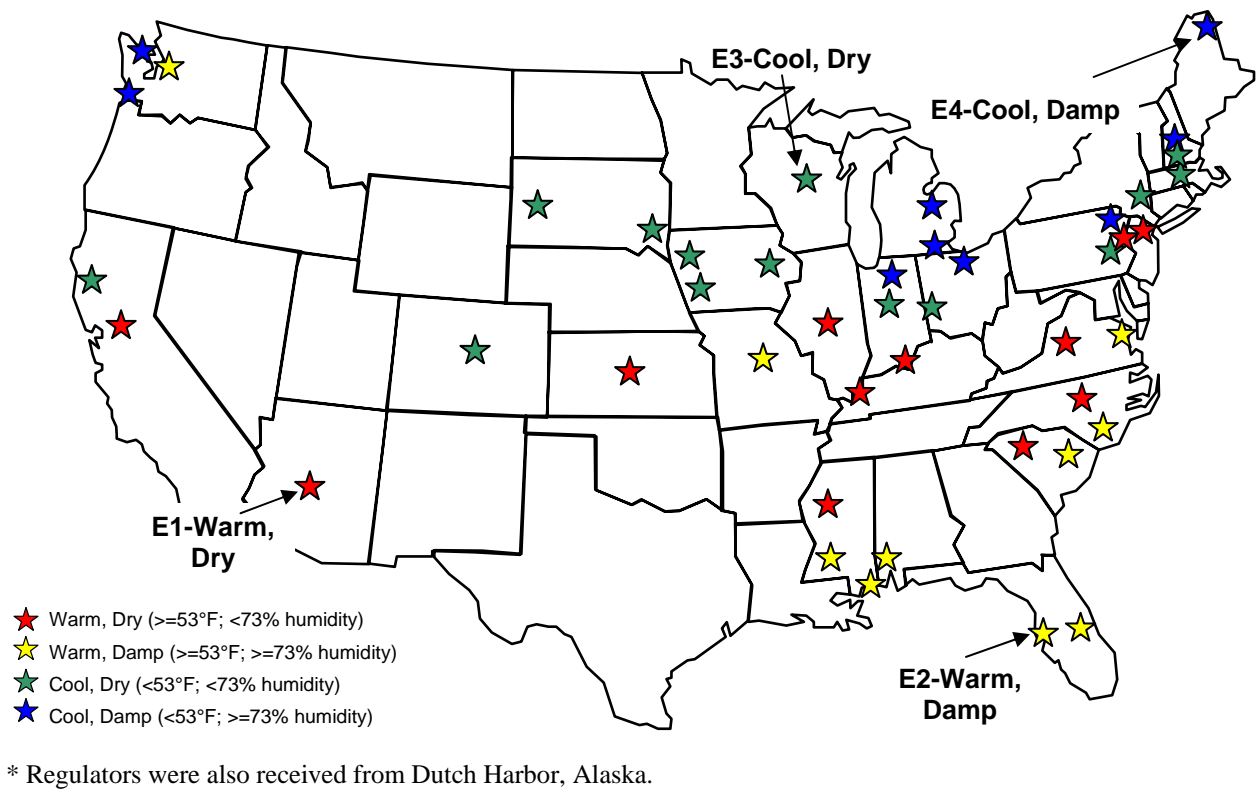

Figure 6. Map illustrating climate regions and source locations of collected regulators.

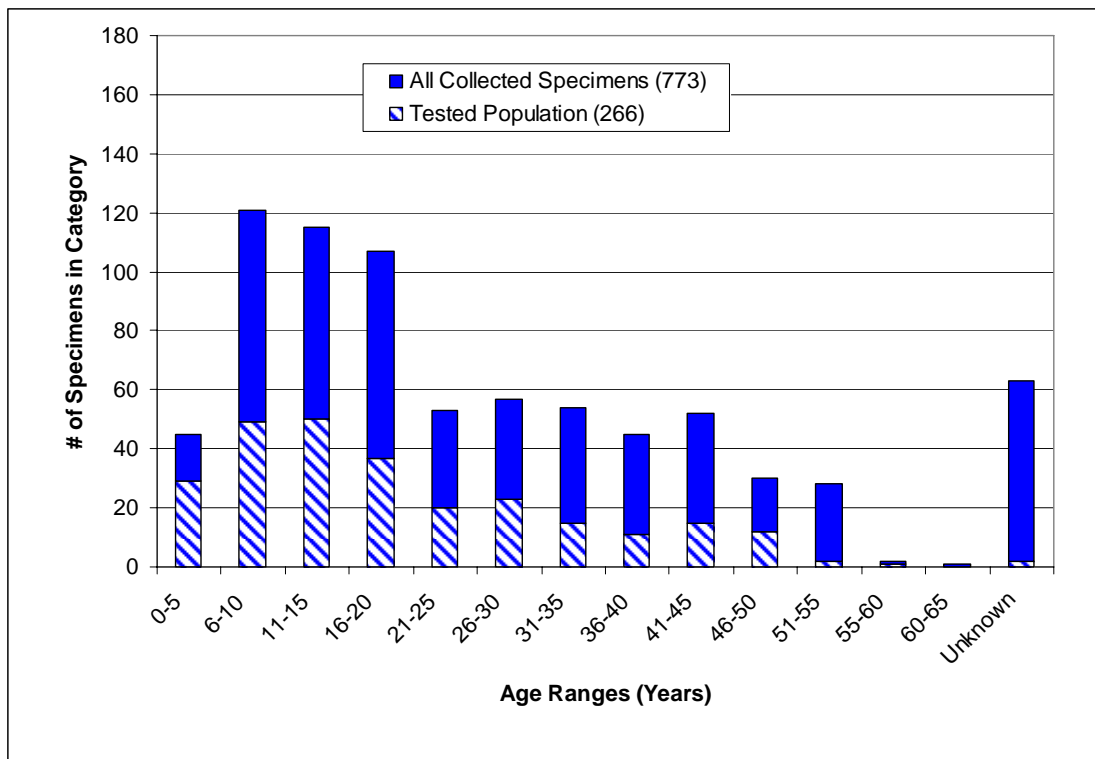

Figure 7. Age distribution of test regulators.

Figures 8 and 9 compare the service environments and source locations where the regulators were obtained. A majority of regulators obtained for testing were from a cool, dry environment. When the regulator samples were selected for testing, a fairly equal distribution of the four environments was chosen to represent the environments in the United States that could potentially degrade regulator performance. As depicted in Figure 9, approximately 56% of the regulator test samples came from South Dakota, Mississippi, and Iowa.

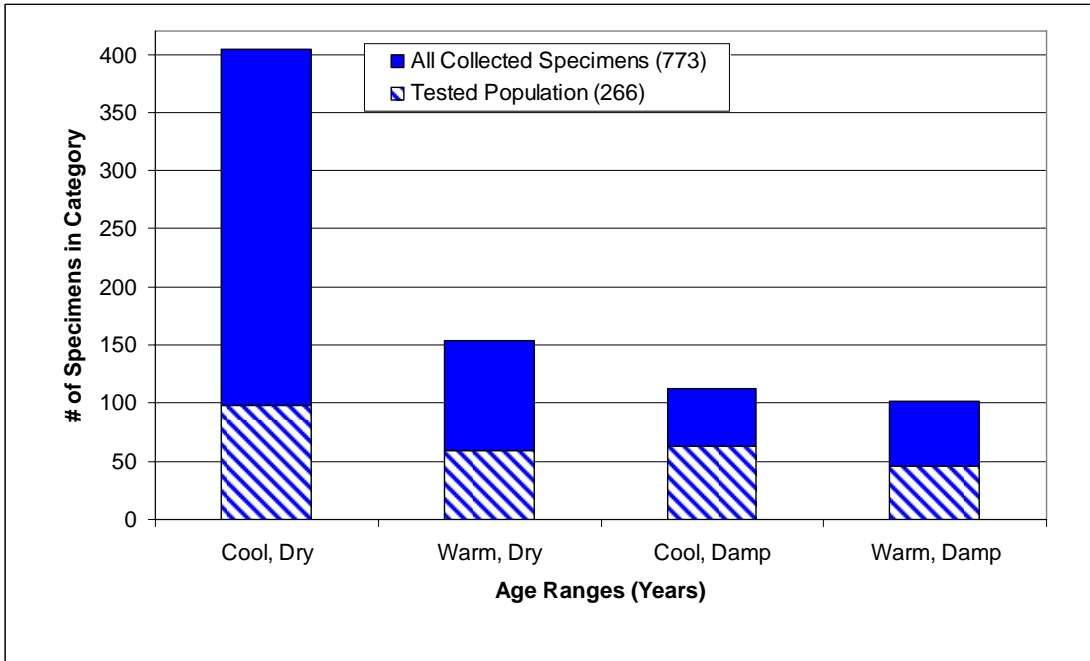

Figure 8. Source environments of test regulators.

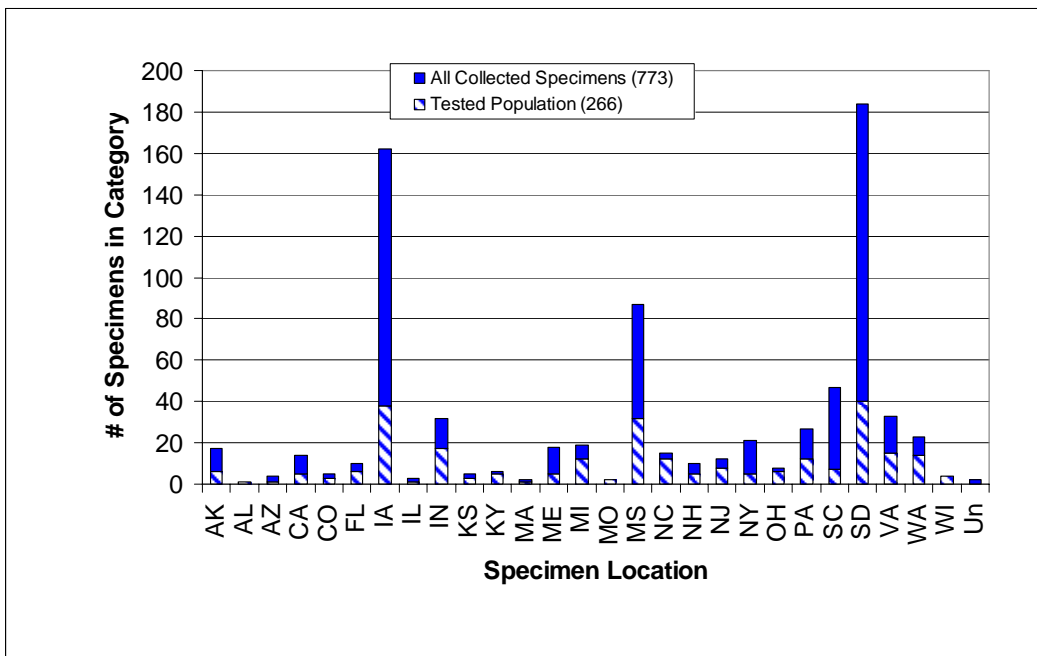

Figure 9. Source locations of test regulators.

Figures 10 and 11 compare the percentage of each regulator type and regulator manufacturer represented in the database. The majority of regulators were from two manufacturers (referred to as Manufacturer A and Manufacturer B) with a nearly equal distribution of first-stage and second-stage regulators received from both manufacturers. Far fewer integral two-stage regulators were received for testing. It is likely we would have received more single-stage regulators had we not focused on collection of regulators designed for two-stage systems.

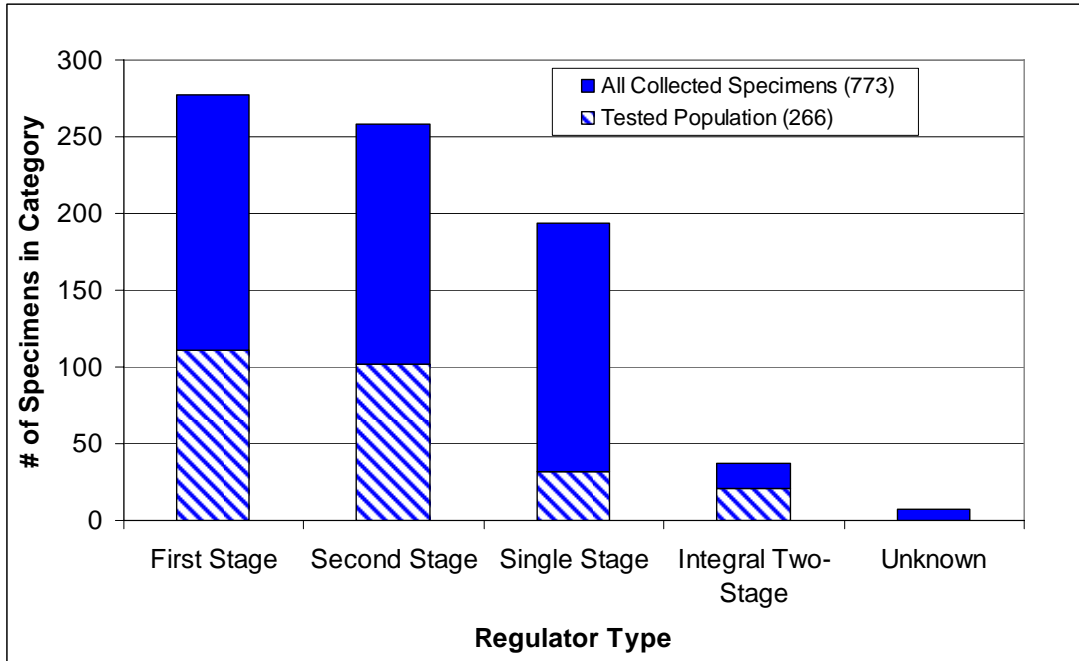

Figure 10. Type distribution of test regulators.

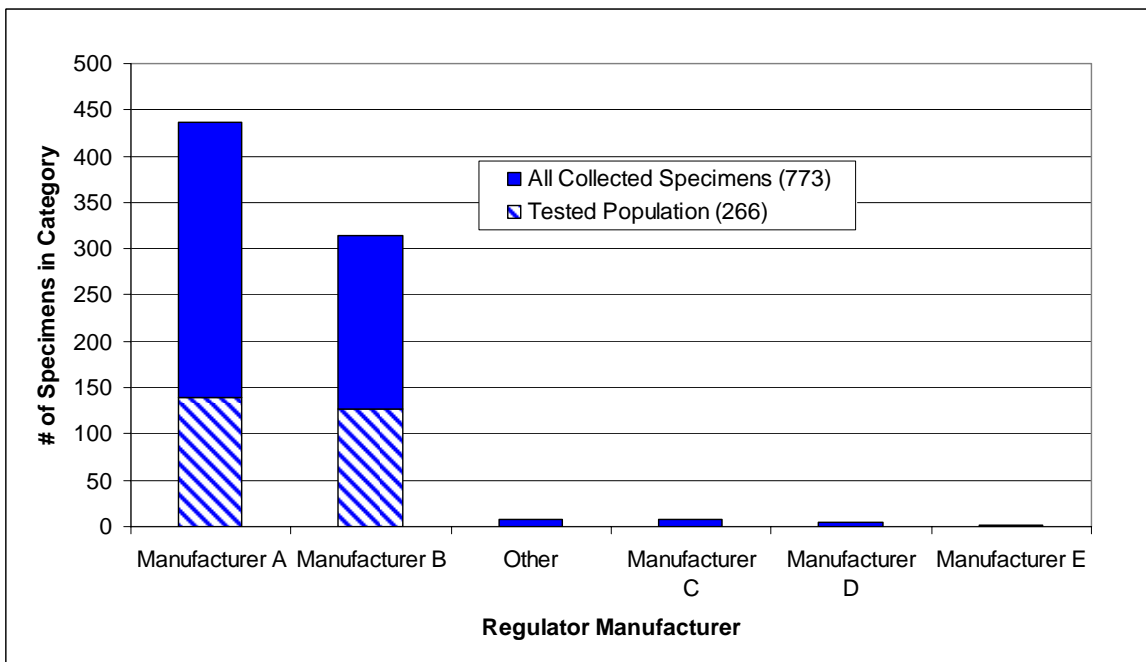

Figure 11. Manufacturer distribution of test regulators.

Even after Battelle contacted over 450 individual propane marketers, a majority of the state propane associations, and submitted bulletins in NPGA and PERC newsletters there were still marketers that responded they were unaware of the project months later. The regulator collection efforts were slow and difficult. During the collection process a number of issues were identified that could be useful if a similar test program is recommended in the future:

- Collection began in the winter of 2004 – 2005. Many of the propane marketers indicated that they were too busy supplying customers with propane to spend time collecting regulators, filling out the information cards, and shipping the regulators to Battelle.
- The large, nationwide propane marketers had reservations about participating in this testing program. Particularly, some felt the study was flawed since regulators are removed from service based on their condition; not because of an arbitrary age designation. This very fact would affect the results of the study since many of the regulators tested would be defective and/or deteriorating. One marketer felt that a better approach would be to collect a representative sample of regulators from operating systems and develop specific procedures to record data before they are removed and for protection of regulators after removal. They recognized that this undertaking would be very expensive both in terms of manpower and time.
- A number of marketers had an over-abundance of single-stage regulators that they were willing to supply; however not as many first-stage, second-stage, or integral two-stage systems were offered. This is primarily due to the state programs that are providing rebates to LP gas marketers to remove their single-stage systems and replace with two-stage regulation systems.
- For many marketers, they have a policy to destroy regulators immediately after removal and subsequently sell them for scrap. Some marketers were not willing to deviate from this policy to supply regulators for this study primarily due to liability issues.
- Some customers own their own tanks and therefore it would be difficult for the marketer to collect those regulators.
- The background data provided for each regulator ranged from good detail about the regulator and its operation to very little known about the regulator including the regulator type (first, second, or single-stage). This made testing more difficult as we had to verify the regulator type before beginning each test. For older regulators, it was not easy to find this information, and we had to contact the manufacturers with the model and part numbers to verify the regulator type. Figure 12 provides an example of an information tag that is lacking the necessary detail, and Figure 13 provides an example of an information tag with sufficient information.

269

PERC Data Sheet on Propane Vapor Pressure Regulators

We appreciate your help in evaluating the performance, durability, and service life of low pressure propane vapor regulators.

	Date Submitted
	1/31/05
Submitter/Contact Name	Phone
[REDACTED]	[REDACTED]
Company Name and Address	
[REDACTED]	
E-mail Address:	
[REDACTED]	
Regulator Manufacturer	Model/Serial Number
<input type="checkbox"/> Fisher <input type="checkbox"/> Sherwood <input type="checkbox"/> Marshall <input type="checkbox"/> RegO <input type="checkbox"/> Other (Specify:)	
Indicate Regulator Type	Year Installed
<input type="checkbox"/> 1st Stage <input type="checkbox"/> 2nd Stage <input type="checkbox"/> Single Stage Put any comments on back.	Date Removed from Service (must be within past month)
Regulator Location (City/State)	
Service Area	Was Regulator Ever Used Anywhere Else?
<input type="checkbox"/> Urban <input type="checkbox"/> Suburban <input type="checkbox"/> Rural	<input type="checkbox"/> No <input type="checkbox"/> Yes If yes, add comment on back
Reason for Regulator Removal	
<input type="checkbox"/> End of manufacturer's recommended service life <input type="checkbox"/> Tank and regulator removed from service at location <input type="checkbox"/> Faulty regulator (give suspected reason in comment area on back) <input type="checkbox"/> Changed from single to dual regulator system <input type="checkbox"/> Other (use comment area on back)	
General Regulator Operating Conditions (Check All That Apply)	
Location at Tank	Location at Building
<input type="checkbox"/> Under dome <input type="checkbox"/> Outside dome <input type="checkbox"/> Shade <input type="checkbox"/> Seasonal sun <input type="checkbox"/> Full sun	<input type="checkbox"/> Near east wall <input type="checkbox"/> Near west wall <input type="checkbox"/> Near north wall <input type="checkbox"/> Near south wall
Appliances within Household	
<input type="checkbox"/> Furnace <input type="checkbox"/> Range <input type="checkbox"/> Water heater <input type="checkbox"/> Dryer <input type="checkbox"/> Other (specify at right)	

Figure 12. Tag lacking information.

415

PERC Data Sheet on Propane Vapor Pressure Regulators

We appreciate your help in evaluating the performance, durability, and service life of low pressure propane vapor regulators.

Date Submitted	
4/18/05	
Submitter/Contact Name	Phone
Company Name and Address	
E-mail Address:	
Regulator Manufacturer	Model/Serial Number
<input type="checkbox"/> Fisher <input type="checkbox"/> Sherwood <input type="checkbox"/> Marshall <input type="checkbox"/> Reg O <input type="checkbox"/> Other (Specify)	4403
Indicate Regulator Type	Year Installed
<input type="checkbox"/> 1st Stage <input checked="" type="checkbox"/> 2nd Stage <input type="checkbox"/> Single Stage Put any comments on back.	4/98
Regulator Location (City/State)	Date Removed from Service (must be within past month)
[Redacted]	4/05
Service Area	Was Regulator Ever Used Anywhere Else?
<input type="checkbox"/> Urban <input type="checkbox"/> Suburban <input checked="" type="checkbox"/> Rural	<input checked="" type="checkbox"/> No <input type="checkbox"/> Yes If yes, add comment on back
Reason for Regulator Removal	
<input type="checkbox"/> End of manufacturer's recommended service life <input checked="" type="checkbox"/> Tank and regulator removed from service at location <input type="checkbox"/> Faulty regulator (give suspected reason in comment area on back) <input type="checkbox"/> Changed from single to dual regulator system <input type="checkbox"/> Other (use comment area on back)	
General Regulator Operating Conditions (Check All That Apply)	
Location at Tank	Location at Building
<input type="checkbox"/> Under dome <input type="checkbox"/> Outside dome <input type="checkbox"/> Shade <input checked="" type="checkbox"/> Seasonal sun <input type="checkbox"/> Full sun	<input checked="" type="checkbox"/> Near east wall <input type="checkbox"/> Near west wall <input type="checkbox"/> Near north wall <input type="checkbox"/> Near south wall
Appliances within Household	<input checked="" type="checkbox"/> Furnace <input type="checkbox"/> Range <input type="checkbox"/> Water heater <input type="checkbox"/> Dryer <input type="checkbox"/> Other (specify at right)
	Logs

Figure 13. Tag with sufficient information.

4.2 Development of Test Protocol

Battelle developed a draft test protocol based on the UL 144 Standard for Safety for LP-Gas Regulators and submitted it to regulator manufacturers, equipment vendors, and propane industry members to gather feedback. Those participants that were asked to provide feedback during the regulator test protocol development included:

- David Kalensky, Tim Cole, and Vasilios Soupos, Gas Technology Institute (GTI)
- Larry Osgood, Consulting Solutions, PERC's program monitor
- Gary Koch, Koch & Associates, propane industry consultant
- Ron Czischke, Underwriters Laboratories (UL)
- Sam McTier, McTier Supply
- Jim Griffin, Fisher Controls
- David Stainbrook, ECII/RegO[®]
- Jeffre Borton, Sherwood Valves
- Jim Peterson, Peterson Engineering.

The sections of UL 144 that the review group felt were the most relevant for testing the performance of in-service regulators included:

- Lock-up Test (Section 21 and Table 21.1)
- Flow Test (Section 22)
- Pressure Relief Test (Section 23)
- Relief Capacity Test (Section 24).

Although UL 144 was used as the basis, some tests were combined (Lock-up and Flow Tests) to expedite the testing process as well as modified to better mimic service conditions of the low pressure propane vapor regulators (see Figure 14). According to UL 144, the lock-up pressure limit is 120% to 160% of the outlet pressure for single-stage, integral two-stage, and second-stage regulators and 130% to 150% of the outlet pressure for first-stage regulators. These values were used as criteria to determine the variance in regulator lock-up performance at the various inlet pressures and flow rates.

In addition, UL 144 requires that the pressure relief devices start-to-discharge at a pressure between 140% and 250% of the outlet pressure for first-stage regulators and 170% to 300% of the outlet pressure for second-stage, single-stage, and integral two-stage regulators. In addition, the relief device was expected to reseal at a pressure greater than 140% of the outlet pressure for first-stage regulators and greater than 170% of the outlet pressure for second-stage, single-stage, and integral two-stage regulators. These values were used as criteria to determine the performance of the regulator pressure relief devices.

The draft documents reviewed by the group contained the regulator testing protocol flowcharts and a narrative of the test procedures and equipment schematics. All participants responded with extremely valuable comments and concerns regarding how the test protocol should be revised.

Highlights of their comments throughout the review process are listed below:

- Modify the order of the tests as originally proposed to the following: (1) Visual Inspection; (2) Flow/Lock-up Tests; (3) PRD/Flow Capacity Tests.
- Remove the leakage test; the leakage test specified in UL 144 is more for regulator design rather than performance. Replace leakage test with a test to monitor for leaks during Lock-up; essentially block in the regulator during lock-up and monitor for leaks and pressure decay.
- Adjust the regulator prior to conducting the tests so that all regulators can be compared on the same basis (note the initial outlet pressure and screw height before adjustment).
- For the Flow/Lock-up Tests start with an average inlet pressure, then move to the lower inlet pressure, and finish with the higher inlet pressure.
- Flow tests should also include flows that mimic pilot light flows (< 1 cfh).
- Basis for regulator “failure” during Lock-up tests should be based on UL 144 Table 21.1; higher lock-up pressures could blow out pilot lights and is a safety issue.
[Note: this was not chosen as a failure during the testing.]
- Rather than use a soapy water solution to detect PRD start-to-discharge, utilize the pressure transducer or a water manometer.
- Make sure to note any contaminants during the visual inspection.

A detailed list of all comments received and Battelle’s response are provided in Appendix B along with the various revisions of the test protocol. The final test protocol is provided in Figure 14.

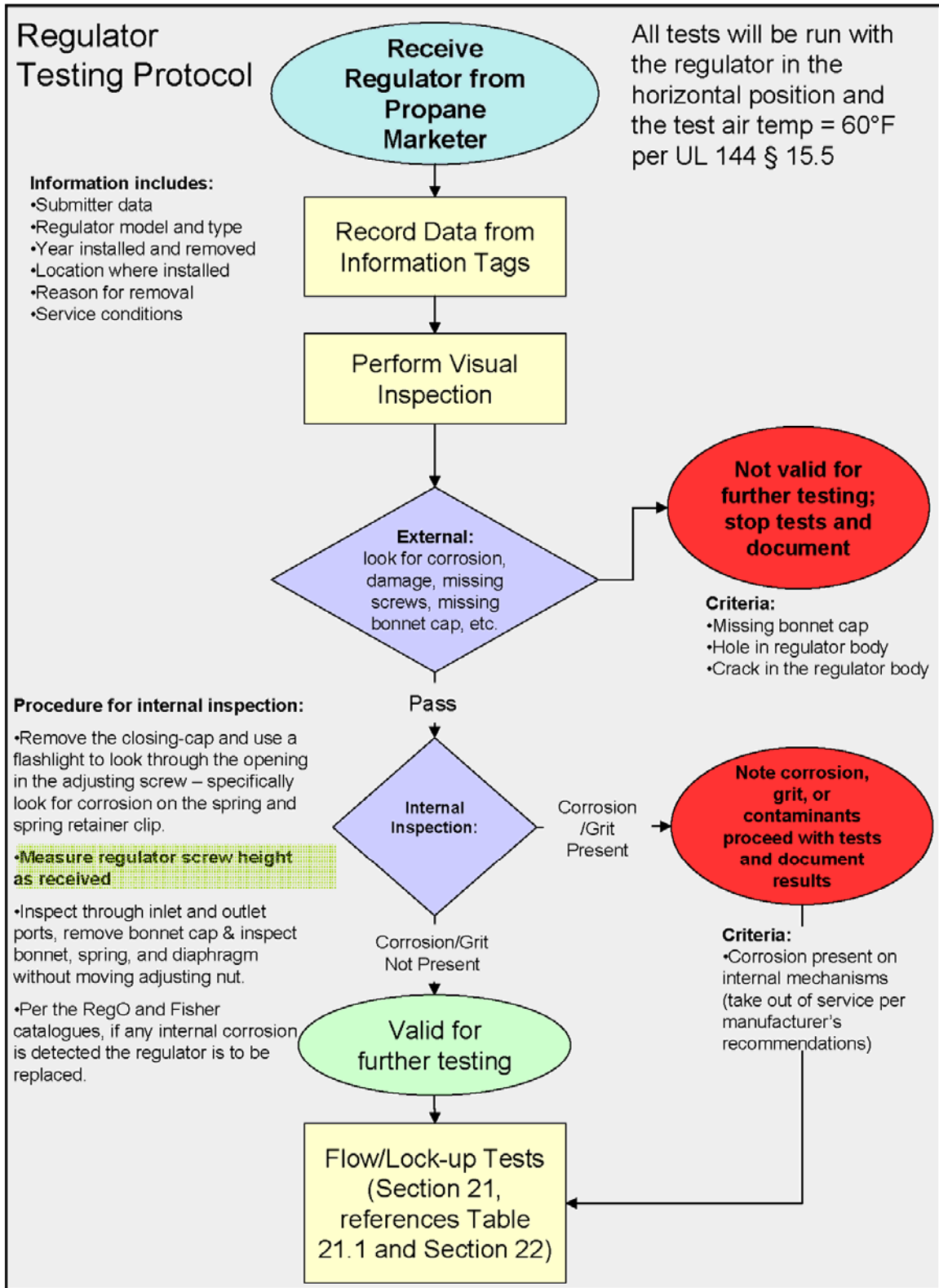

Figure 14. Regulator test protocol.

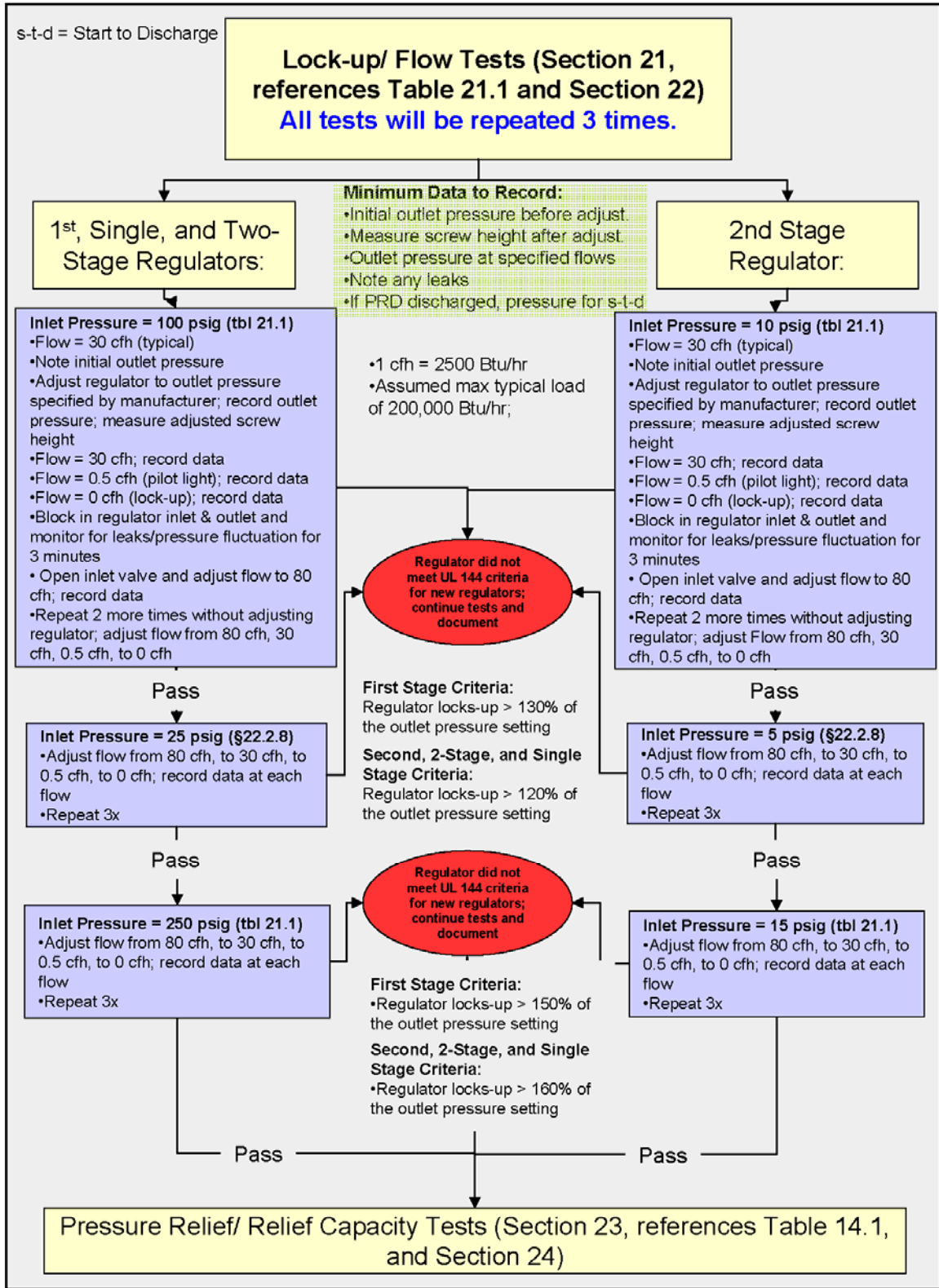

Figure 14. Regulator test protocol (continued).

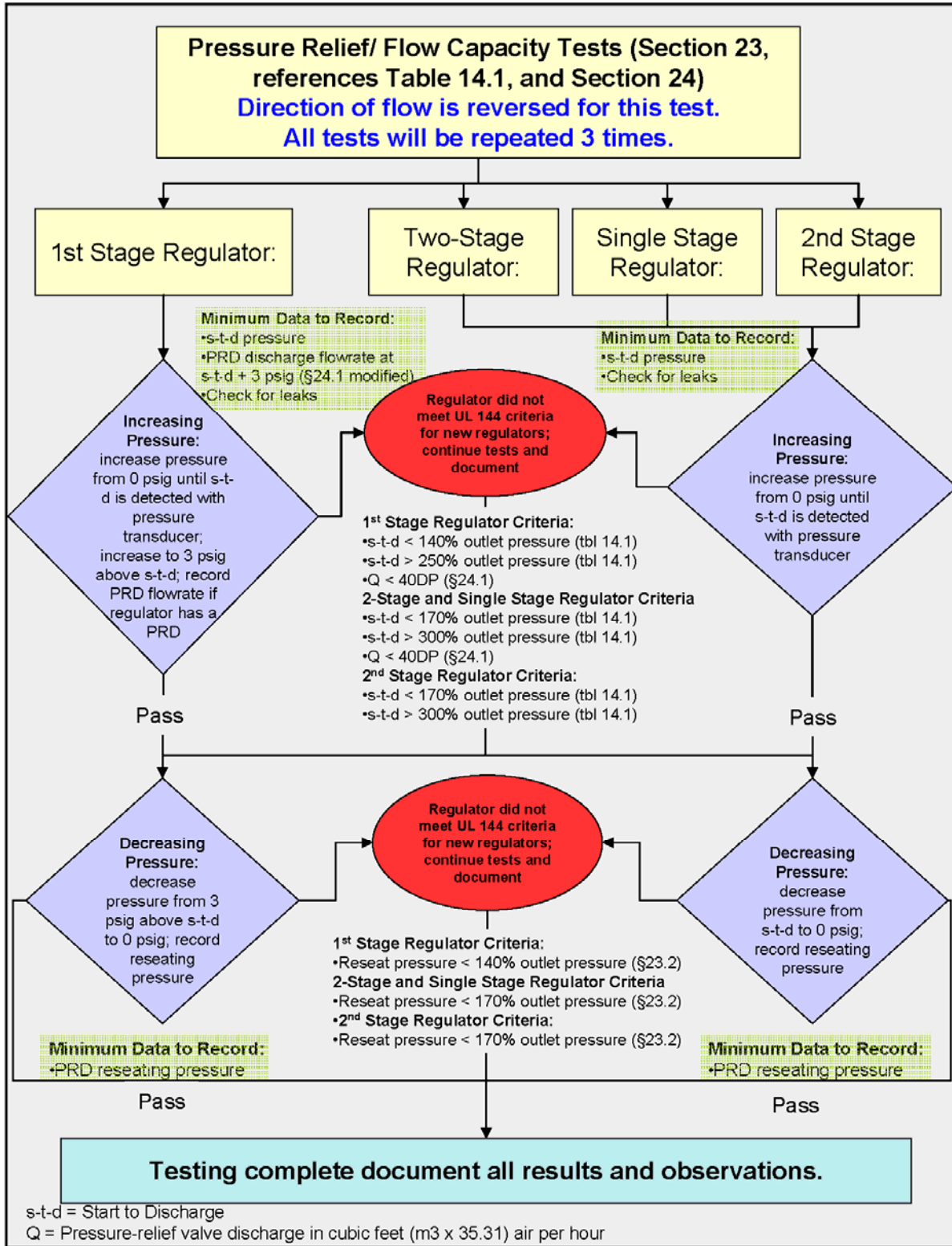

Figure 14. Regulator test protocol (continued).

4.3 Design and Construction of Test Rig

Battelle designed and constructed a test rig for regulator testing based on the protocol discussed previously. The test rig included a 300 psig air compressor, a number of pressure regulators and pressure transducers, a flow meter, various piping/tubing, and data acquisition system. In addition to the data acquisition system, a data sheet was developed to manually record the test data throughout the test cycle. All testing was conducted at Battelle's Pipeline Simulation Facility in West Jefferson, Ohio.

Figure 15 provides a schematic of the test rig, showing the various pressure control regulators and flow control valves. The computerized data acquisition, control system and solenoid valves helped to prevent accidental over-pressurization of the regulator under test and the pressure instrumentation. During shakedown of the test rig, Battelle identified leakage problems with the solenoid valves that required addition of several check valves (also shown in Figure 15). Figure 16 shows the front view of the test rig, with the pressure control regulators visible near the top of the board, and a regulator under test mounted on the bench. Not shown is the data acquisition and control system located to the left of the bench. Figure 17 shows the back of the test rig, with the flow control valve and control and data wiring. Figure 18 shows the air supply compressor. Figure 19 is an example of the datasheet used for all regulator testing.

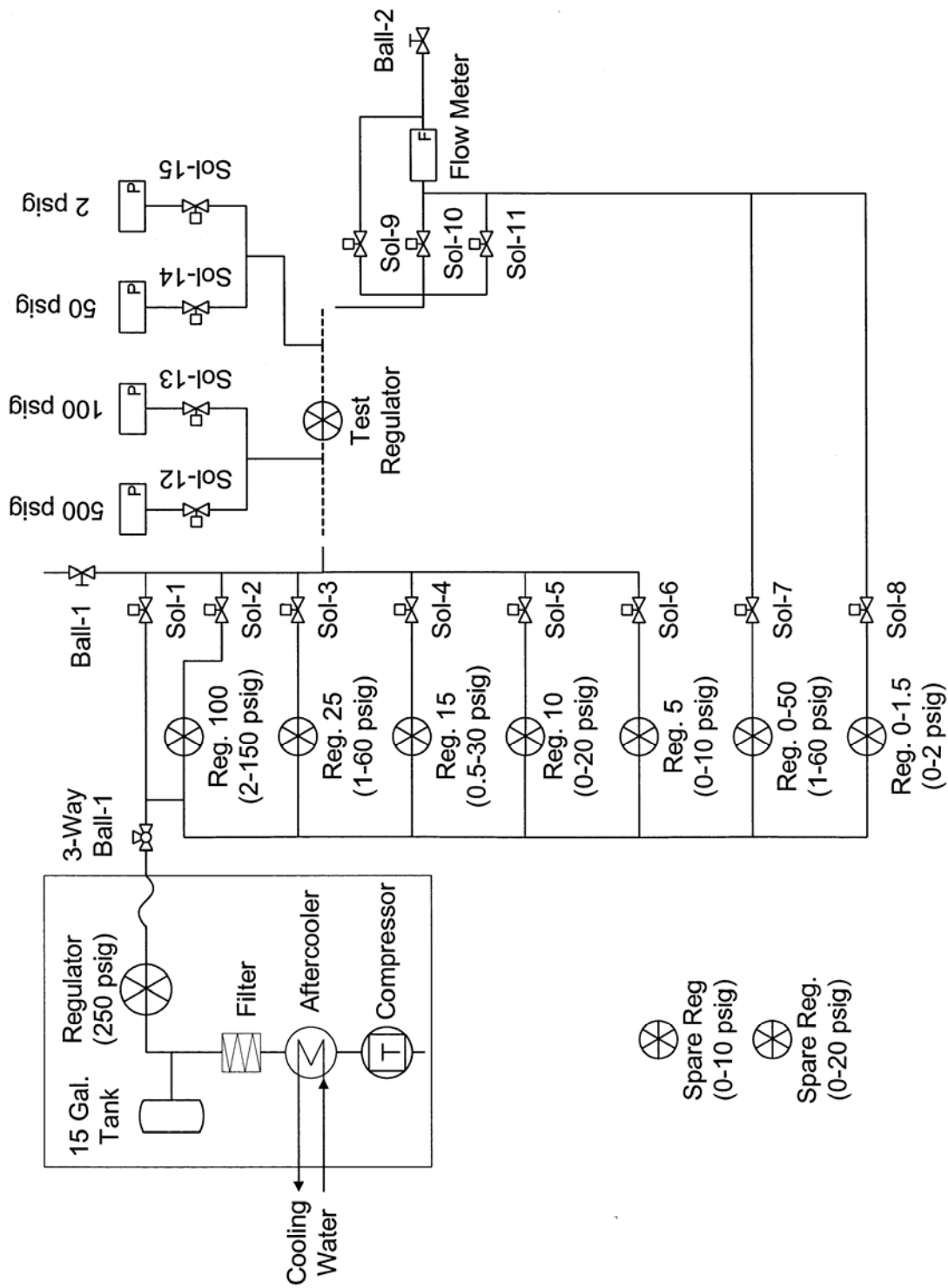

Figure 15. Regulator test rig schematic.



Figure 16. Regulator test stand — front view.

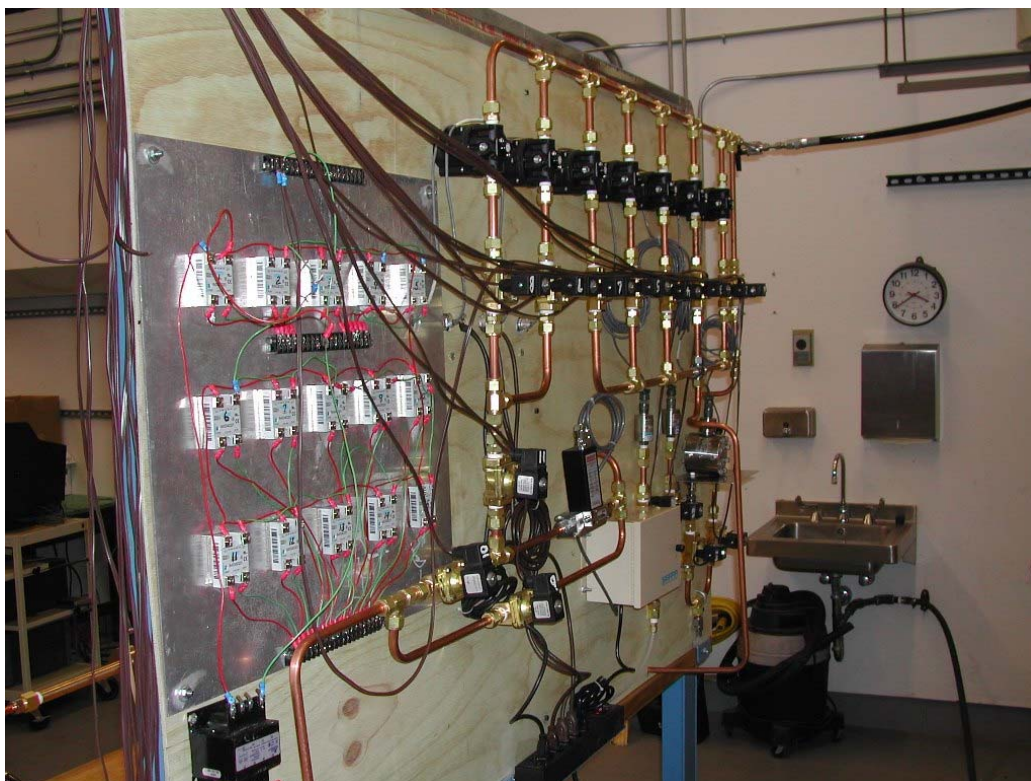

Figure 17. Regulator test stand — rear view.

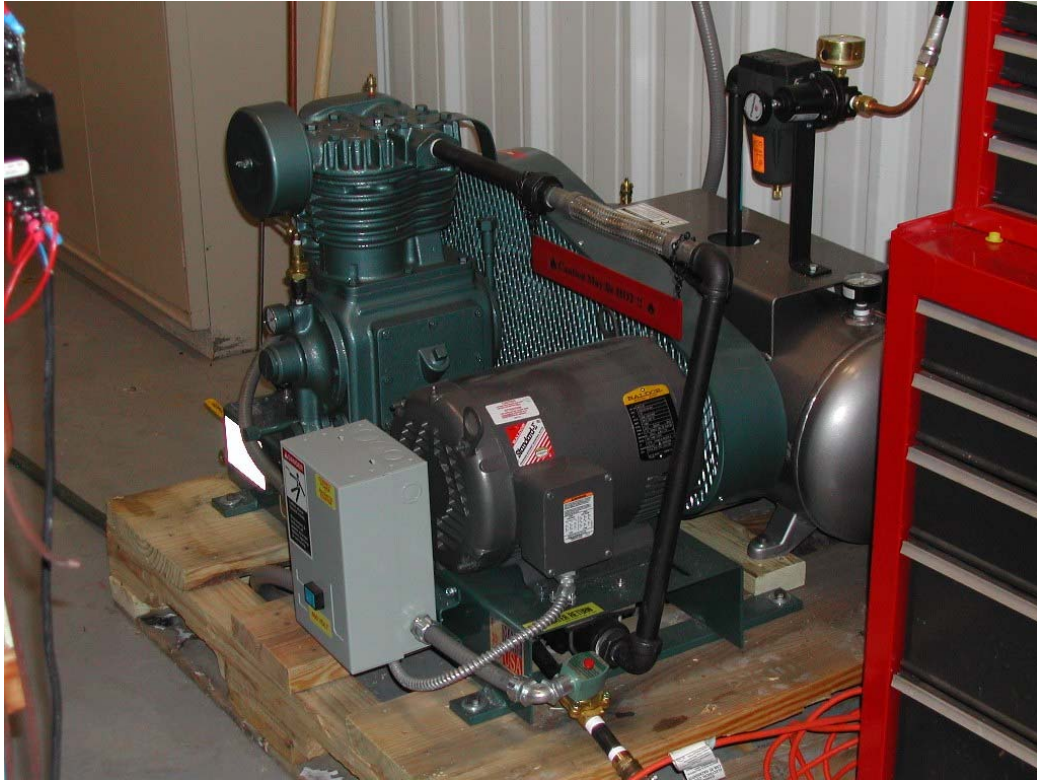

Figure 18. Compressor for test air supply.

REGULATOR TESTING DATA SHEET																									
REGULATOR INFORMATION																									
Regulator ID:		Regulator Manuf:	<input type="checkbox"/>	Fisher	Regulator Type:	<input type="checkbox"/>	1st Stage	4) LOCK-UP/FLOW TESTS																	
Regulator Model/Serial #:			<input type="checkbox"/>	Marshall		<input type="checkbox"/>	2nd Stage																		
Regulator Date Stamp:			<input type="checkbox"/>	Sherwood		<input type="checkbox"/>	Single Stage																		
			<input type="checkbox"/>	RegO		<input type="checkbox"/>	Integral																		
			<input type="checkbox"/>	Other (specify)		<input type="checkbox"/>	Other?	Inlet Pressure = <input type="checkbox"/> 100 psig (1st & Single Stage) or <input type="checkbox"/> 10 psig (2nd Stage)																	
TEST DATA																									
Date:		Time:		Operator:		Trial #1 (CHECK FOR LEAKS @ LOCK-UP)								Trial #2		Trial #3									
						30 cfh	0.5 cfh	0 cfh	80 cfh	80 cfh	30 cfh	0.5 cfh	0 cfh	80 cfh	30 cfh	0.5 cfh	0 cfh								
External Visual (note any corrosion, damage, missing parts, etc.) Comments:						Internal Visual (note any corrosion or grit, damage, etc.) Comments:								Test Flow Rates (cfh)											
														Measured Flow Rates (cfh)											
														Outlet pressures (psig):											
														Leak detected during test (chk box if yes)?											
														Did PRD discharge (chk box if yes)?											
														If yes, record PRD s-t-d pressure (psig):											
														Comments (if leak detected, describe where leak occurred):											
2) MEASURE SCREW HEIGHT (before adjustment)						Inlet Pressure = <input type="checkbox"/> 25 psig (1st & Single Stage) or <input type="checkbox"/> 5 psig (2nd Stage)																			
Initial Screw Height (inches):																									
3) ADJUST REGULATOR																									
Inlet Pressure = <input type="checkbox"/> 100 psig (1st & Single Stage) or <input type="checkbox"/> 10 psig (2nd Stage)																									
Flowrate = 30 cfh																									
Outlet pressure (psig) before adjustment (30 cfh):																									
Adjust regulator to manuf. specified outlet pressure (psig)		5, 10, 15, or 20 psig for 1st stage; 11" W.C. for 2nd and Single Stage																							
Measure Screw Height (after adjustment) (inches)																									
5) PRESSURE RELIEF/ FLOW CAPACITY TESTS																									
Inlet Pressure = <input type="checkbox"/> 0 - 50 psig (1st and Single Stage) <input type="checkbox"/> 0 - 2 psig (2nd Stage)																									
Time Start:																									
Time Finish:																									
						Trial #1		Trial #2		Trial #3															
PRD s-t-d pressure (psig):						cfh	psig	cfh	psig	cfh	psig	cfh	psig	cfh	psig										
PRD dischrg flow at s-t-d + 3 psig (1st Stage Only)						cfh	psig	cfh	psig	cfh	psig	cfh	psig	cfh	psig										
PRD reseating pressure (psig):																									
Comments (any leaks detected?):																									
														Test Flow Rates (cfh)											
														Measured Flow Rates (cfh)											
														Outlet pressures (psig):											
														Leak detected during test (chk box if yes)?											
														Did PRD discharge (chk box if yes)?											
														If yes, record PRD s-t-d pressure (psig):											
														Comments (if leak detected, describe where leak occurred):											

* ADJUST FLOWS TO WITHIN +/- 5% OF THE SPECIFIED VALUE

Figure 19. Regulator datasheet.

This page intentionally left blank.

5.0 REGULATOR SELECTION, TESTING, AND EVALUATION (TASK 2)

All regulators received were labeled, documented, and placed in individually sealed bags. In total, 266 regulators were tested by Battelle using test methods similar to those specified in UL 144 for LP-Gas Regulators (newly manufactured). The details of the test protocol are explained in Section 4.2 of this report. The 266 regulators were subjected to external and internal inspections to identify any significant corrosion, damage, or missing components; lock-up testing at three different inlet pressures and four different flowrates; and pressure relief testing. A database of the test results was compiled and is provided in Volume 2. Included within the database are:

- visual inspection information;
- measurements of initial and adjusted outlet pressures;
- screw height before and after adjustment;
- outlet pressures during lock-up testing;
- start-to-discharge, reseal pressures, and flow rate during the pressure relief testing; and
- documented leaks or other issues identified during testing.

This has resulted in a comprehensive database that allows direct and detailed comparison of regulator performance.

Before the regulators were tested, basic information was recorded on the data sheet and external and internal visual inspections were performed. The purpose of the visual inspections was to identify and document any significant corrosion, damage, or missing components.

Prior to lock-up and pressure relief testing, all regulators were adjusted to the manufacturer's specified outlet pressure. There was much debate regarding whether or not the regulators should be adjusted prior to testing. Some participants in the protocol development felt that adjusting the regulator could influence the test results and as such should be tested as received; however others felt that all regulators needed to be compared on an equivalent basis and should be adjusted to the manufacturer's specified outlet pressure. It was also identified that it would be helpful to know if a number of regulators are significantly out of adjustment. To compromise, it was decided that the "as received" adjusting screw height and outlet pressure would be measured and recorded and then the regulator adjusted to the manufacturer's outlet pressure setpoint and the screw height re-measured.

Regulator lock-up was measured at three different inlet pressures and recorded in three successive trials for each inlet pressure. Lock-up was recorded for first-stage, integral two-stage, and single-stage regulators at 100 psig, 25 psig, and 250 psig inlet pressures while lock-up for second-stage regulators was recorded at 10 psig, 5 psig, and 15 psig inlet pressures. Additional regulator outlet pressure data was recorded for three additional flowrates: 80 cfh to represent a maximum household flowrate (corresponding to an appliance load of 200,000 Btu/hr), 30 cfh to represent a typical household flowrate (corresponding to an appliance load of 75,000 Btu/hr), and 0.5 cfh to mimic pilot light flowrates. The initial test sequence began with the middle inlet

pressure and a flowrate of 30 cfh. The flowrates were then cycled down to 0.5 cfh and lock-up at 0 cfh then raised to 80 cfh. After the initial sequence, the tests were repeated two more times starting at a flowrate of 80 cfh and cycling down to lock-up. The later sequence was followed for the low inlet pressure and finally the high inlet pressure before proceeding with the pressure relief tests.

The pressure relief device start-to-discharge and reseal pressures of each regulator were measured and recorded in three successive trials for each test. The flow capacity of the relief device was measured between each discharge/reseat sequence. In these tests, the start-to-discharge pressure was measured by slowly pressurizing the regulator until the first indication of air escaping was observed using the flow meter. In many cases the relief device did not open fully until the pressure was increased further. Subsequently, the pressure in the regulator was reduced carefully until no air flow from the pressure relief device was observed. This was recorded as the reseal pressure. After the initial sequence, the start-to-discharge pressure and reseating pressure tests were repeated two more times.

5.1 Regulator Selection

The sample of 266 regulators for testing was chosen in the following manner:

- *Operating Environment.* Average temperature and humidity data were obtained for each location, based on data from the nearest airport to the city where the regulator was located. The locations were classified into four categories:
 - Warm; dry ($\geq 53^{\circ}\text{F}$; $< 73\%$ humidity),
 - Warm; damp ($\geq 53^{\circ}\text{F}$; $\geq 73\%$ humidity),
 - Cool; dry ($< 53^{\circ}\text{F}$; $< 73\%$ humidity), and
 - Cool; damp ($< 53^{\circ}\text{F}$; $\geq 73\%$ humidity).

The criteria of temperature and humidity were chosen to ensure the most even distribution of locations among the categories. An alternative would have been to choose the criteria so that the individual regulators (rather than the locations) were distributed evenly among the categories. This method, however, was not chosen as it would have put undue weight on the locations from which many regulators were obtained.

- *Regulator Age.* The ages of the regulators were also classified into four categories: less than 10 years, 10-19 years, 20-29 years, and 30 years or greater.
- *Regulator Manufacturer.* Most of the regulators came from two manufacturers and therefore heavily dominate the sample selection.
- *Regulator Type.* Initially, regulators were selected from all types (first-stage, second-stage, single-stage, and integral two-stage) that were provided for this study. However, after approximately 30 single-stage regulators were tested, it was decided to remove these from the sample pool. Although single-stage regulators are still in service, they are no longer permitted for new installations per NFPA 58. For this reason, it was decided to focus on test samples consisting only of first-stage, second-stage, or integral two-stage regulators.

A sample of four regulators was drawn from each manufacturer/regulator type/location category/age category combination (or group). In many of these groups there were less than four regulators available, in which case all available regulators in the group were included in the sample. If more than four regulators were available, four were sampled at random. If a regulator from a previous sample did not yield any data, an additional sample from that group was chosen, whenever possible.

The reason for regulator removal was not used as a selection criterion. However, 45 of the regulators had been labeled by the submitters as “faulty” or “leaking through”. Fifty-four tested regulators did not have the reason for removal identified by the submitters.

Collection of regulators ceased on September 30, 2005 with a total of 773 regulators so that testing of the remaining samples could be completed by mid-November. It was originally proposed that 400 regulators should be tested as part of this program. Unfortunately, due to the slow collection of regulators necessary to get a good sample distribution the test sample size was decreased to 266 regulators.

The test sample size was determined from analyzing the test data collected after approximately 200 regulators were tested. The test data were analyzed to determine how many additional regulators should be tested to have a fairly high confidence in the test results. The statistical analysis indicated that the data trends would not change significantly with larger sample populations (for example from 100 to 200, and 200 to 300). As such, it was decided that a total of approximately 300 regulators would be tested to ensure that the project was completed by year end and encompasses a reasonable sample of regulators with varying ages, geographic locations, types, and models.

Figure 20 depicts the estimated average and 95% upper confidence bounds for the average value of the outlet pressure at lock-up (0 cfh) for a first-stage regulator with 100 psi of inlet pressure. The solid line represents the current estimate of the average outlet pressure by age. The coarser dotted line represents an estimate of the 95% upper confidence bound for the average outlet pressure based on a total of approximately 300 sampled regulators. The finer dotted line represents an estimate of the 95% upper confidence bound for the average outlet pressure based on a total of approximately 500 sampled regulators. There is negligible difference between the two lines, indicating that there would be little benefit to sampling an additional 200 regulators to fulfill the 400 regulator samples originally planned for testing.

Figure 21 shows that the estimated average and 95% upper confidence bounds for the average value of the outlet pressure at lock-up (0 cfh) for a second-stage regulator with 10 psi of inlet pressure. Results for the second-stage regulators are similar to those for the first-stage regulators.

Estimated Average and Upper Confidence Bounds for the Average
 Type=1st_stag press=100

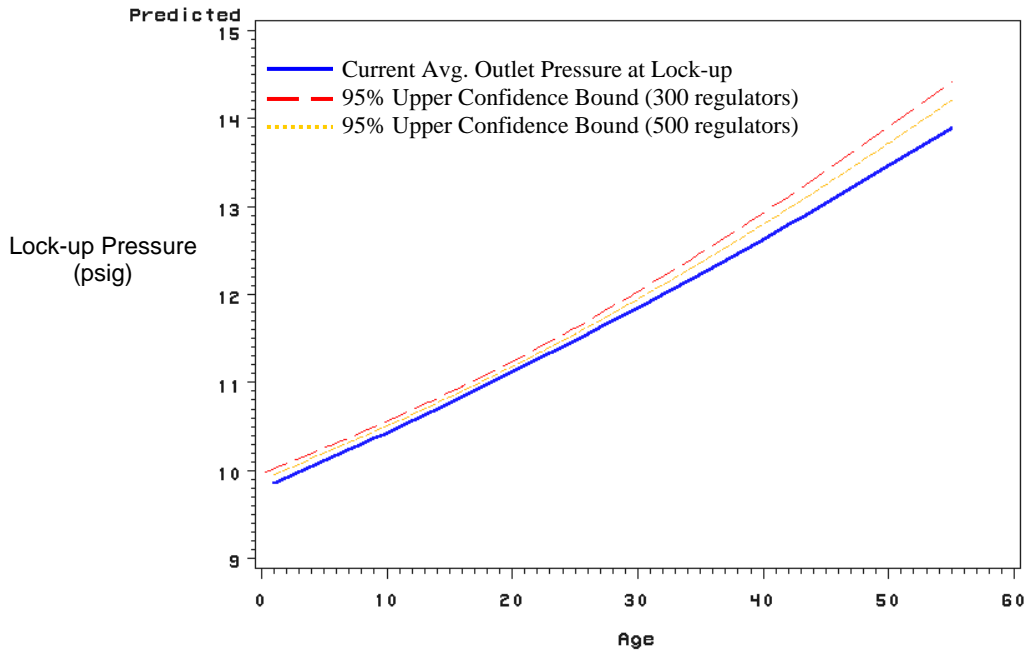

Figure 20. Average and 95% upper confidence bounds for first-stage regulators with 100 psi inlet pressure.

Estimated Average and Upper Confidence Bounds for the Average
 Type=2nd_stag press=10

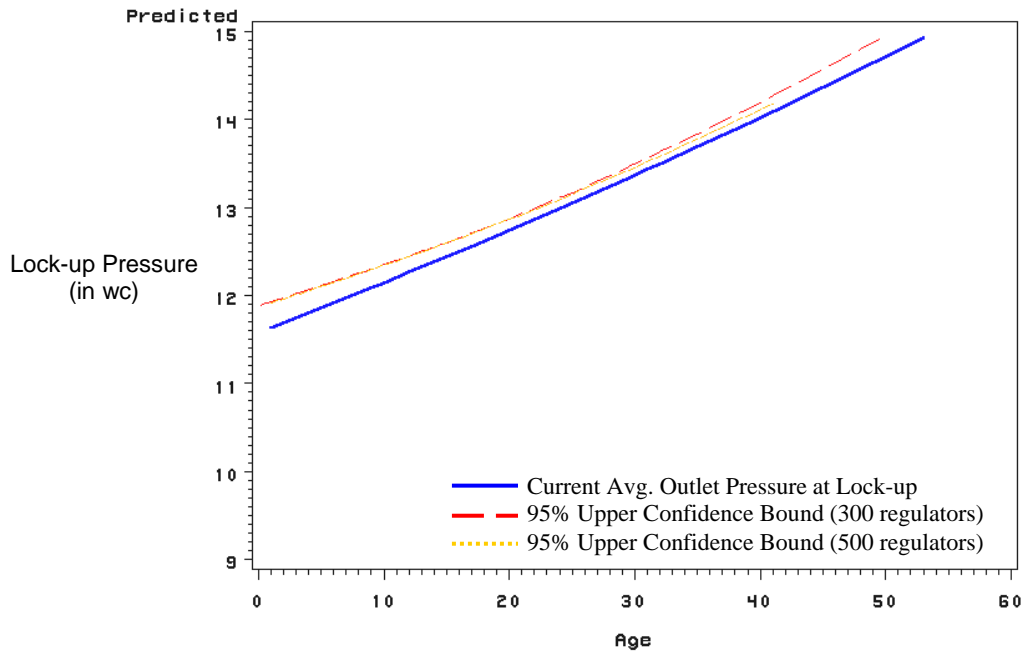

Figure 21. Average and 95% upper confidence bounds for second-stage regulators with 10 psi inlet pressure.

5.2 Visual Inspection of Regulators

Before the regulators were tested, basic information about each regulator was recorded on the data sheet and external and internal visual inspections were performed. The purpose of the visual inspections was to identify and document any significant corrosion, damage, or missing components to possibly correlate regulator condition with performance issues. Additionally, the regulators were adjusted prior to testing to ensure that all regulators were tested on the same basis for easier comparison of results.

5.2.1 Visual External Inspection

Issues identified from the external visual inspection included:

- Corroded regulator body
- Missing parts (screws, vent screens, bonnet caps)
- Excessive paint
- Physical damage to the regulator (holes or cracks in the regulator body)
- Removal of fittings (corroded; difficult to remove; could not remove)
- Excessive dirt.

If the regulator was missing the bonnet cap it was considered unsuitable for testing. The bonnet cap protects the regulator from dirt, debris, and rain/snow entering the regulator body and possibly affecting regulator performance. Since it could not be determined if contaminants due to the missing bonnet cap or the regulator itself caused any performance issues it was decided to remove these regulators from the test pool.

Additionally, several regulators had fittings that were difficult to remove or seized in place. These fittings were removed if it could be done without causing damage to the regulator. Regulators with seized fittings were not tested. Regulators that were corroded or had an accumulation of dirt/debris on the exterior of the regulator were documented but still tested to determine their performance. Those regulators with cracks or holes in the regulator body could not be tested and the regulator damage was documented in the database.

5.2.2 Visual Internal Inspection

Issues identified from the internal visual inspection include:

- Cross-threaded adjusting screw
- Damage to adjusting screw
- Adjusting spring seized in place or stiff
- Burred threads
- Internal corrosion and/or contaminants (dirt, oil).

Several regulators had adjusting screws that were seized or stiff and difficult to adjust. These regulators were still tested unless other issues were identified such as leaks through the PRD or the outlet pressure would not stabilize. Regulators that had cross-threaded adjusting screws or damage to the internal components were not tested. Most other regulators with issues identified during the internal inspection were tested and the inspection findings were documented in the database.

5.2.3 Regulator Adjustment

Prior to lock-up and pressure relief testing, all regulators were adjusted to the manufacturer's specified outlet pressure. There was debate regarding whether the regulators should be adjusted prior to testing. Some participants in the test protocol development felt that adjusting the regulator could influence the test results and as such should be tested as received; however others felt that all regulators needed to be compared on an equivalent basis and should be adjusted to the manufacturer's specified outlet pressure. It was also identified that it would be helpful to know if a number of regulators are significantly out of adjustment. To address both concerns, it was decided that the "as received" adjusting screw height and outlet pressure would be measured and recorded and then the regulator adjusted to the manufacturer's outlet pressure setpoint and the screw height re-measured.

Some regulators were set by the manufacturer and the adjusting spring could not be accessed to make any adjustments. These regulators were tested as received and noted in the database.

During adjustment, some regulators had poor regulation, extremely slow lock-up, or leaked through the regulator. In these instances, the information was noted on the data sheet and the test was stopped.

5.3 Regulator Test Results and Evaluation

This section of the report first provides a summary of the regulator test results and then discusses their possible meaning, interpretation and implications. A general overview of regulator performance is provided in Tables 3 through 6 with more detailed discussions in the subsequent sections.

Table 3. Overview of first-stage regulator performance.

Regulator ID	Regulator Manufacturer	REGULATOR INFORMATION				INSPECTIONS		LOCK-UP		PRESSURE RELIEF		REASON FOR FAILURE
		Regulator Type	Regulator Age (years)	Climate	Regulator Status	Service Area	Reason for Regulator Removal	External Inspection	Internal Inspection and Adjustment	Moderate Pressure	Low High Pressure	
3	Manufacturer B	1st Stage	3	Cool, Damp	ME	Rural	Fully regulator					
4	Manufacturer A	1st Stage	1	Cool, Dry	NH	Rural	Fully regulator					
7	Manufacturer A	1st Stage	15	Cool, Dry	SD	Rural	Tank and regulator removed from service at location					
8	Manufacturer A	1st Stage	17	Cool, Dry	SD	Rural	Tank and regulator removed from service at location					
23	Manufacturer A	1st Stage	1	Cool, Dry	MA	Rural	End of manufacturer's recommended service life					
26	Manufacturer B	1st Stage	27	Cool, Dry	IA	Rural	End of manufacturer's recommended service life					DO NOT TEST - Adjustment screws threaded without adjust
46	Manufacturer A	1st Stage	9	Cool, Dry	SD	Rural	Tank and regulator removed from service at location					Leak through crimp in regulator body
50	Manufacturer B	1st Stage	9	Cool, Damp	WA	Suburban	Fully regulator					
57	Manufacturer A	1st Stage	20	Warm, Dry	KS	Rural	End of manufacturer's recommended service life					
70	Manufacturer A	1st Stage	7	Cool, Dry	CO	Rural	Tank and regulator removed from service at location					
95	Manufacturer A	1st Stage	28	Cool, Dry	SD	Rural	Tank and regulator removed from service at location					
104	Manufacturer A	1st Stage	1	Warm, Dry	VA	Rural	Fully regulator					Peak 15 cfm to attain 10 psid outlet pressure. Regulator set by manufacturer, initially 12.06 psig and dropped slowly to 10.58 psig
105	Manufacturer A	1st Stage	1	Warm, Dry	VA	Rural	Other					Outlet pressure fluctuates between 9.5 psig and 10 psig. Leaked through PRD during adjustment
110	Manufacturer A	1st Stage	6	Cool, Damp	OH	Rural	Fully regulator					
120	Manufacturer A	1st Stage	10	Cool, Dry	OH	Rural	Tank and regulator removed from service at location					Regulator model does not have an integral relief valve
121	Manufacturer B	1st Stage	16	Warm, Damp	NC	Rural	Tank and regulator removed from service at location					Regulator model does not have an integral relief valve
125	Manufacturer B	1st Stage	15	Warm, Dry	NC	Rural	End of manufacturer's recommended service life					Regulator model does not have an integral relief valve
126	Manufacturer A	1st Stage	15	Warm, Damp	NC	Suburban	End of manufacturer's recommended service life					Spring locked in place. Regulator model does not have an integral relief valve
131	Manufacturer B	1st Stage	13	Cool, Dry	IA	Rural	End of manufacturer's recommended service life					Leaked all pressure through fittings, tightened and confirmed with tests
132	Manufacturer B	1st Stage	10	Cool, Dry	IA	Rural	End of manufacturer's recommended service life					Missing pressure gauge dial, replaced and confirmed with tests
133	Manufacturer B	1st Stage	17	Cool, Dry	IA	Rural	End of manufacturer's recommended service life					Regulator model does not have an integral relief valve
135	Manufacturer A	1st Stage	15	Cool, Dry	IA	Rural	End of manufacturer's recommended service life					Adjusting spring frozen
145	Manufacturer A	1st Stage	2	Warm, Damp	MS	Rural	Changed from single to dual regulator system					Using bonnet cap, regulator performed within UK criteria when tested
151	Manufacturer A	1st Stage	9	Warm, Damp	MS	Rural	Tank and regulator removed from service at location					DO NOT TEST - Could not remove fittings
164	Manufacturer B	1st Stage	42	Warm, Damp	MS	Rural	Tank and regulator removed from service at location					DO NOT TEST - Could not remove fittings
167	Manufacturer B	1st Stage	2	Warm, Damp	MS	Rural	Tank and regulator removed from service at location					Start-to-discharge = 20.29 psig, 15 psi regulator
175	Manufacturer B	1st Stage	16	Warm, Dry	NC	Suburban	End of manufacturer's recommended service life					User threads burned, cleaned and continued with test
177	Manufacturer B	1st Stage	8	Warm, Dry	NC	Rural	Other					Adjusting spring frozen. Regulator model does not have an integral relief valve
183	Manufacturer A	1st Stage	11	Warm, Damp	MS	Rural	Tank and regulator removed from service at location					Self adjusting spring
184	Manufacturer A	1st Stage	2	Warm, Damp	MS	Rural	Tank and regulator removed from service at location					User fitting rusty and difficult to remove
187	Manufacturer A	1st Stage	16	Warm, Damp	MS	Rural	Tank and regulator removed from service at location					Missing pressure gauge dial
189	Manufacturer A	1st Stage	24	Warm, Damp	MS	Rural	Tank and regulator removed from service at location					Inlet and outlet fittings rusty and difficult to remove
192	Manufacturer A	1st Stage	13	Warm, Damp	MS	Rural	Tank and regulator removed from service at location					Regulator model does not have an integral relief valve
195	Manufacturer A	1st Stage	10	Warm, Damp	MS	Rural	Tank and regulator removed from service at location					Pressure relief screen missing
219	Manufacturer A	1st Stage	15	Warm, Damp	MS	Rural	End of manufacturer's recommended service life					Regulator model does not have an integral relief valve
222	Manufacturer A	1st Stage	15	Cool, Damp	M	Rural	End of manufacturer's recommended service life					Regulator model does not have an integral relief valve
230	Manufacturer A	1st Stage	15	Cool, Dry	SD	Rural	Tank and regulator removed from service at location					Regulator model does not have an integral relief valve
244	Manufacturer A	1st Stage	17	Cool, Dry	SD	Rural	Tank and regulator removed from service at location					Inlet and outlet fittings rusty and difficult to remove
247	Manufacturer B	1st Stage	8	Cool, Dry	SD	Rural	Tank and regulator removed from service at location					PRD resisted at 12.47 psig
258	Manufacturer B	1st Stage	32	Cool, Dry	IA	Rural	End of manufacturer's recommended service life					Could not adjust regulator, pressure would not stabilize during adjustment
264	Manufacturer B	1st Stage	41	Cool, Dry	NC	Suburban	End of manufacturer's recommended service life					DO NOT TEST - Leaked through small hole at the bottom of the regulator
267	Manufacturer A	1st Stage	41	Cool, Dry	IA	Rural	End of manufacturer's recommended service life					Leaked through regulator, stopped test at 27 psid outlet pressure
275	Manufacturer A	1st Stage	47	Cool, Dry	IA	Rural	End of manufacturer's recommended service life					Outlet pressure would not stabilize during adjustment
280	Manufacturer A	1st Stage	46	Cool, Dry	IA	Rural	End of manufacturer's recommended service life					Could not adjust regulator, locked in place
281	Manufacturer A	1st Stage	31	Cool, Dry	IA	Rural	End of manufacturer's recommended service life					Regulator model does not have an integral relief valve
290	Manufacturer A	1st Stage	11	Cool, Dry	IA	Rural	End of manufacturer's recommended service life					Pressure relief screen missing
299	Manufacturer A	1st Stage	56	Cool, Dry	SD	Rural	Tank and regulator removed from service at location					Regulator model does not have an integral relief valve
301	Manufacturer A	1st Stage	32	Cool, Dry	IA	Rural	End of manufacturer's recommended service life					Regulator model does not have an integral relief valve
311	Manufacturer A	1st Stage	5	Cool, Damp	M	Rural	Tank and regulator removed from service at location					Regulator model does not have an integral relief valve
321	Manufacturer B	1st Stage	57	Cool, Dry	SD	Rural	End of manufacturer's recommended service life					Inlet and outlet fittings rusty and difficult to remove
324	Manufacturer A	1st Stage	16	Cool, Damp	MI	Rural	Other					Low outlet pressures occur with adjustment all the way open
326	Manufacturer A	1st Stage	17	Cool, Dry	SD	Rural	Tank and regulator removed from service at location					Missing bonnet cap; regulator performed within UK criteria when tested; regulator model does not have an integral relief valve
332	Manufacturer A	1st Stage	24	Warm, Dry	WA	Suburban	Tank and regulator removed from service at location					Adjusting screw backed all the way out. Regulator model does not have an integral relief valve
338	Manufacturer A	1st Stage	8	Warm, Dry	VA	Rural	Tank and regulator removed from service at location					Regulator model does not have an integral relief valve
341	Manufacturer B	1st Stage	5	Cool, Damp	WA	Suburban	Tank and regulator removed from service at location					Regulator model does not have an integral relief valve
344	Manufacturer A	1st Stage	27	Warm, Dry	KY	Rural	Other					Regulator model does not have an integral relief valve
361	Manufacturer B	1st Stage	22	Warm, Dry	CA	Urban	Tank and regulator removed from service at location					Regulator model does not have an integral relief valve
416	Manufacturer A	1st Stage	7	Warm, Dry	VA	Rural	Tank and regulator removed from service at location					Regulator model does not have an integral relief valve
417	Manufacturer A	1st Stage	10	Warm, Dry	VA	Rural	Tank and regulator removed from service at location					Regulator model does not have an integral relief valve
425	Manufacturer A	1st Stage	18	Warm, Dry	VA	Rural	End of manufacturer's recommended service life					Regulator model does not have an integral relief valve
430	Manufacturer A	1st Stage	43	Cool, Dry	SC	Rural	Tank and regulator removed from service at location					Regulator model does not have an integral relief valve
441	Manufacturer A	1st Stage	12	Warm, Dry	SC	Rural	Other					Regulator model does not have an integral relief valve
449	Manufacturer B	1st Stage	7	Warm, Damp	VA	Rural	End of manufacturer's recommended service life					Chatters and leaks through PRD during adjustment
450	Manufacturer B	1st Stage	7	Warm, Damp	VA	Rural	Tank and regulator removed from service at location					Outlet pressure would not stabilize during adjustment; adjusting nut frozen in regulator
460	Manufacturer B	1st Stage	41	Warm, Dry	VA	Rural	Fully regulator					Chatters and leaks through PRD during adjustment
461	Manufacturer B	1st Stage	46	Warm, Dry	VA	Rural	Tank and regulator removed from service at location					Regulator model does not have an integral relief valve
468	Manufacturer A	1st Stage	18	Cool, Dry	WI	Urban	End of manufacturer's recommended service life					Regulator model does not have an integral relief valve
470	Manufacturer A	1st Stage	41	Cool, Dry	PA	Suburban	Other: model 34H outlet					Regulator model does not have an integral relief valve
472	Manufacturer B	1st Stage	8	Warm, Dry	NJ	Suburban	Other					Regulator model does not have an integral relief valve
474	Manufacturer B	1st Stage	36	Warm, Dry	NJ	Suburban	End of manufacturer's recommended service life					Regulator model does not have an integral relief valve
475	Manufacturer A	1st Stage	29	Cool, Dry	WI	Rural	End of manufacturer's recommended service life					Regulator model does not have an integral relief valve
484	Manufacturer A	1st Stage	27	Cool, Damp	IN	Rural	End of manufacturer's recommended service life					Regulator model does not have an integral relief valve
487	Manufacturer A	1st Stage	25	Cool, Damp	IN	Rural	End of manufacturer's recommended service life					Regulator model does not have an integral relief valve
488	Manufacturer A	1st Stage	43	Cool, Damp	IN	Rural	End of manufacturer's recommended service life					Regulator model does not have an integral relief valve
489	Manufacturer A	1st Stage	39	Cool, Damp	IN	Rural	End of manufacturer's recommended service life					Regulator model does not have an integral relief valve
491	Manufacturer B	1st Stage	10	Warm, Damp	FL	Suburban	Tank and regulator removed from service at location					Regulator model does not have an integral relief valve
492	Manufacturer B	1st Stage	1	Warm, Damp	FL	Suburban	Tank and regulator removed from service at location					Inlet and outlet fittings difficult to remove burned threads
493	Manufacturer B	1st Stage	3	Warm, Damp	FL	Suburban	Fully regulator					Very rusty, did not regulate well
507	Manufacturer A	1st Stage	45	Cool, Dry	IA	Urban	End of manufacturer's recommended service life					Regulator model does not have an integral relief valve
509	Manufacturer A	1st Stage	4	Warm, Damp	VA	Rural	Tank and regulator removed from service at location					Regulator model does not have an integral relief valve
511	Manufacturer A	1st Stage	6	Warm, Dry	VA	Rural	Tank and regulator removed from service at location					Regulator model does not have an integral relief valve
538	Manufacturer A	1st Stage	16	Warm, Dry	PA	Suburban	Tank and regulator removed from service at location					Regulator model does not have an integral relief valve
544	Manufacturer A	1st Stage	42	Cool, Damp	IN	Rural	End of manufacturer's recommended service life					Stumped to leak through PRV at 0 cfm and 25 psig. Max lock-up = 14.97 psig
553	Manufacturer A	1st Stage	39	Warm, Dry	IN	Rural	End of manufacturer's recommended service life					Regulator model does not have an integral relief valve
554	Manufacturer A	1st Stage	48	Cool, Damp	IN	Rural	End of manufacturer's recommended service life					Regulator model does not have an integral relief valve
557	Manufacturer A	1st Stage	33	Cool, Damp	IN	Rural	End of manufacturer's recommended service life					Regulator model does not have an integral relief valve
559	Manufacturer B	1st Stage	49	Cool, Damp	IN	Rural	End of manufacturer's recommended service life					Regulator model does not have an integral relief valve
563	Manufacturer A	1st Stage	28	Cool, Damp	IN	Rural	End of manufacturer's recommended service life					Outlet pressure would not stabilize during lock-up testing
565	Manufacturer B	1st Stage	16	Cool, Damp	M	Rural	Tank and regulator removed from service at location					Chatters and leaks through regulator at 250 psig (this is correct) and 80 cfm
571	Manufacturer B	1st Stage	10	Cool, Damp	M	Rural	Fully regulator					Leaked through PRD during adjustment
572	Manufacturer B	1st Stage	19	Cool, Damp	M	Rural	Tank and regulator removed from service at location					Regulator model does not have an integral relief valve
593	Manufacturer A	1st Stage	17	Cool, Damp	ME	Rural	Tank and regulator removed from service at location					Regulator model does not have an integral relief valve
614	Manufacturer A	1st Stage	22	Cool, Dry	IA	Rural	End of manufacturer's recommended service life					Slow lock-up at 100 psig inlet pressure
615	Manufacturer B	1st Stage	15	Cool, Dry	IA	Rural	Fully regulator					Regulator model does not have an integral relief valve. Max lock-up = 17.8 psig
617	Manufacturer B	1st Stage	10	Cool, Dry	IA	Rural	Fully regulator					Leak around PRD hose
623	Manufacturer B	1st Stage	25	Cool, Dry	IA	Urban	Fully regulator					Low relief and lock-up pressures (13.97 psid and 13.88 psid, respectively)
628	Manufacturer A	1st Stage	26	Cool, Dry	IA	Urban	End of manufacturer's recommended service life					DO NOT TEST - Leaked through crimp in regulator body at 250 psig and 80 cfm
636	Manufacturer A	1st Stage	25	Warm, Dry	NJ	Suburban	End of manufacturer's recommended service life					Regulator model does not have an integral relief valve
657	Manufacturer B	1st Stage	4	Cool, Dry	NY	Urban	Other: recessed tank, change of regs					Low inlet and outlet pressures (10.9 psid and 10.3 psig, respectively)
657	Manufacturer B	1st Stage	4	Cool, Dry	NY	Urban	Other: recessed tank					Regulator model does not have an integral relief valve
697	Manufacturer B	1st Stage	43	Cool, Dry	SD	Rural	End of manufacturer's recommended service life					Chatters and leaks through regulator at 80 cfm and 100 psig inlet pressure
718	Manufacturer A	1st Stage	27	Cool, Dry	IA	Rural	End of manufacturer's recommended service life					Regulator model does not have an integral relief valve
733	Manufacturer A	1st Stage	27	Cool, Dry	IA	Rural	End of manufacturer's recommended service life					Chatters and leaks through regulator at 80 cfm and 100 psig inlet pressure
757	Manufacturer B	1st Stage	47	Cool, Dry	SD	Rural	End of manufacturer's recommended service life					Regulator model does not have an integral relief valve
760	Manufacturer B	1st Stage	26	Cool, Dry	SD	Rural	End of manufacturer's recommended service life					Regulator model does not have an integral relief valve
778	Manufacturer A	1st Stage	11	Cool, Damp	AK	Rural	End of manufacturer's recommended service life					DO NOT TEST - Could not remove fittings
783	Manufacturer B	1st Stage	14	Warm, Damp	MS	Rural	Fully regulator					Outlet pressure would not stabilize; pressure continued to drop at 100 psig inlet pressure and 80 cfm

Table 4. Overview of second-stage regulator performance.

REGULATOR INFORMATION										INSPECTIONS				LOCK-UP			PRESSURE RELIEF		REASON FOR FAILURE
Regulator ID	Regulator Manufacturer	Regulator Type	Regulator Age (years)	Climate	Regulator Location State	Service Area	Reason for Regulator Removal	External Visual Inspection	Internal Inspection and Adjustment	Moderate Inlet Pressure	High Inlet Pressure	Start-to-Discharge Pressure	Resetting Pressure	REASON FOR FAILURE					
2ND STAGE REGULATORS																			
2	Manufacturer A	2nd Stage	4	Cool, Damp	ME	Rural	Faulty regulator	O	O	O	O	O	O	O	O	O			
5	Manufacturer A	2nd Stage	4	Cool, Damp	NH	Rural	Tank and regulator removed from service at location	O	O	O	O	O	O	O	O	O			
6	Manufacturer A	2nd Stage	1	Cool, Damp	NH	Rural	Tank and regulator removed from service at location	O	O	O	O	O	O	O	O	O			
20	Manufacturer A	2nd Stage	11	Cool, Dry	SD	Rural	Tank and regulator removed from service at location	O	O	O	O	O	O	O	O	O	DID NOT TEST - Vent missing over screen & adjusting screw is bent		
21	Manufacturer B	2nd Stage	38*	Warm, Damp	MO	Rural	End of manufacturer's recommended service life	O	O	O	O	O	O	O	O	O			
22	Manufacturer B	2nd Stage	41	Warm, Damp	MD	Rural	Faulty regulator	O	O	O	O	O	O	O	O	O			
30	Manufacturer B	2nd Stage	15	Cool, Dry	IA	Rural	End of manufacturer's recommended service life	O	O	O	O	O	O	O	O	O	Leak through regulator at 10 psig inlet and 0 psig outlet		
33	Manufacturer B	2nd Stage	15	Cool, Dry	IA	Urban	End of manufacturer's recommended service life	O	O	O	O	O	O	O	O	O	Max start-to-discharge pressure = 36.3" W.C.		
34	Manufacturer B	2nd Stage	11*	Cool, Dry	IA	Urban	End of manufacturer's recommended service life	O	O	O	O	O	O	O	O	O	Adjustment all the way down, low outlet pressure (8.8" W.C.)		
42	Manufacturer B	2nd Stage	18	Warm, Dry	L	Suburban	End of manufacturer's recommended service life	O	O	O	O	O	O	O	O	O	Outlet fitting rusty and difficult to remove		
47	Manufacturer B	2nd Stage	7	Cool, Dry	SD	Rural	End of manufacturer's recommended service life	O	O	O	O	O	O	O	O	O	Max lock-up = 21.8" W.C.; slow lock-up		
48	Manufacturer B	2nd Stage	3	Cool, Damp	WA	Rural	Faulty regulator	O	O	O	O	O	O	O	O	O	Max lock-up = 14.81" W.C.; regulator chatters		
49	Manufacturer B	2nd Stage	8	Cool, Damp	WA	Suburban	Faulty regulator	O	O	O	O	O	O	O	O	O	leaked through PRD during adjustment		
51	Manufacturer B	2nd Stage	11	Cool, Damp	WA	Suburban	Faulty regulator	O	O	O	O	O	O	O	O	O	DID NOT TEST - Could not remove inlet fitting		
52	Manufacturer B	2nd Stage	10	Cool, Damp	WA	Suburban	Faulty regulator	O	O	O	O	O	O	O	O	O	leaked through regulator at 10 psig inlet and 0.5 cph		
60	Manufacturer B	2nd Stage	37	Warm, Dry	MS	Rural	Tank and regulator removed from service at location	O	O	O	O	O	O	O	O	O	Max start-to-discharge pressure = 34.5" W.C.		
65	Manufacturer B	2nd Stage	16	Cool, Damp	OH	Rural	Tank and regulator removed from service at location	O	O	O	O	O	O	O	O	O			
68	Manufacturer B	2nd Stage	13	Cool, Damp	OH	Suburban	Tank and regulator removed from service at location	O	O	O	O	O	O	O	O	O	Max lock-up = 13.5" W.C.; Max start-to-discharge pressure = 47.2" W.C.		
71	Manufacturer A	2nd Stage	2	Cool, Dry	CO	Rural	Tank and regulator removed from service at location	O	O	O	O	O	O	O	O	O	Bad leak through adjusting screw		
72	Manufacturer A	2nd Stage	16	Cool, Dry	CO	Rural	Tank and regulator removed from service at location	O	O	O	O	O	O	O	O	O	Chatters and leaks through PRD at 30 cph and 10 psig inlet		
90	Manufacturer D	2nd Stage	46	Cool, Dry	SD	Rural	Tank and regulator removed from service at location	O	O	O	O	O	O	O	O	O	Max lock-up = 61.1" W.C.		
100	Manufacturer D	2nd Stage	44	Cool, Dry	PA	Suburban	Other service work at customer location & found old regulator	O	O	O	O	O	O	O	O	O	Very rusty; Max lock-up = 13.8" W.C.		
113	Manufacturer A	2nd Stage	13	Cool, Dry	NH	Rural	End of manufacturer's recommended service life	O	O	O	O	O	O	O	O	O	Leak through PRD at 30 cph and 10 psig inlet		
117	Manufacturer A	2nd Stage	9	Warm, Dry	OH	Rural	End of manufacturer's recommended service life	O	O	O	O	O	O	O	O	O	Max lock-up = 14.7" W.C.; Max start-to-discharge pressure = 33.8" W.C.		
118	Manufacturer A	2nd Stage	8	Cool, Dry	IN	Rural	Tank and regulator removed from service at location	O	O	O	O	O	O	O	O	O	Leak through PRD at 30 cph and 10 psig inlet		
119	Manufacturer A	2nd Stage	9	Cool, Dry	OH	Rural	Tank and regulator removed from service at location	O	O	O	O	O	O	O	O	O			
123	Manufacturer A	2nd Stage	14	Warm, Damp	NC	Suburban	End of manufacturer's recommended service life	O	O	O	O	O	O	O	O	O			
124	Manufacturer A	2nd Stage	16	Warm, Damp	NC	Rural	End of manufacturer's recommended service life	O	O	O	O	O	O	O	O	O			
128	Manufacturer B	2nd Stage	16	Warm, Damp	NC	Rural	End of manufacturer's recommended service life	O	O	O	O	O	O	O	O	O	Leak through regulator at 10 psig inlet and 0 cph (lock-up)		
130	Manufacturer B	2nd Stage	17	Warm, Damp	NC	Suburban	End of manufacturer's recommended service life	O	O	O	O	O	O	O	O	O	DID NOT TEST - Cracked regulator body		
136	Manufacturer B	2nd Stage	35	Cool, Dry	IA	Rural	End of manufacturer's recommended service life	O	O	O	O	O	O	O	O	O	DID NOT TEST - Could not remove outlet fitting		
155	Manufacturer A	2nd Stage	4	Warm, Damp	MS	Rural	Tank and regulator removed from service at location	O	O	O	O	O	O	O	O	O	Pressure relief screen missing		
156	Manufacturer A	2nd Stage	11	Warm, Damp	MS	Rural	Tank and regulator removed from service at location	O	O	O	O	O	O	O	O	O			
168	Manufacturer A	2nd Stage	10	Warm, Damp	MS	Rural	Tank and regulator removed from service at location	O	O	O	O	O	O	O	O	O	Leak through PRD at 30 cph and 10 psig inlet; vent screen missing		
170	Manufacturer A	2nd Stage	22	Warm, Dry	KY	Suburban	End of manufacturer's recommended service life	O	O	O	O	O	O	O	O	O	Inlet fitting rusty and difficult to remove; Max start-to-discharge pressure = 35.5" W.C.		
171	Manufacturer B	2nd Stage	14	Warm, Dry	IN	Suburban	End of manufacturer's recommended service life	O	O	O	O	O	O	O	O	O	Pressure relief screen missing		
174	Manufacturer B	2nd Stage	14	Warm, Dry	KY	Rural	End of manufacturer's recommended service life	O	O	O	O	O	O	O	O	O	Pressure relief screen rusty		
176	Manufacturer B	2nd Stage	16	Warm, Dry	NC	Rural	End of manufacturer's recommended service life	O	O	O	O	O	O	O	O	O	Bonnet cap missing; Regulator performed within UL criteria when tested		
179	Manufacturer A	2nd Stage	15	Warm, Dry	NC	Rural	End of manufacturer's recommended service life	O	O	O	O	O	O	O	O	O	leaked through PRD during adjustment		
180	Manufacturer A	2nd Stage	8	Warm, Damp	MS	Rural	Tank and regulator removed from service at location	O	O	O	O	O	O	O	O	O	Max start-to-discharge = 35.8" W.C.		
191	Manufacturer B	2nd Stage	48	Warm, Damp	MS	Rural	Tank and regulator removed from service at location	O	O	O	O	O	O	O	O	O	leaked through PRD during adjustment		
207	Manufacturer A	2nd Stage	34	Cool, Damp	ME	Rural	Tank and regulator removed from service at location	O	O	O	O	O	O	O	O	O	Max start-to-discharge = 35.8" W.C.		
208	Manufacturer B	2nd Stage	47	Cool, Damp	ME	Urban	Tank and regulator removed from service at location	O	O	O	O	O	O	O	O	O	DID NOT TEST - Could not remove inlet fitting		
211	Manufacturer A	2nd Stage	15	Cool, Damp	MI	Rural	End of manufacturer's recommended service life	O	O	O	O	O	O	O	O	O	Pressure relief screen missing		
223	Manufacturer B	2nd Stage	14	Cool, Damp	MI	Rural	End of manufacturer's recommended service life	O	O	O	O	O	O	O	O	O	leak through PRD at 30 cph and 10 psig inlet; vent screen missing		
228	Manufacturer B	2nd Stage	47	Cool, Dry	SD	Rural	Tank and regulator removed from service at location	O	O	O	O	O	O	O	O	O	Max start-to-discharge pressure = 40.1" W.C. during the test 1		
255	Manufacturer B	2nd Stage	32	Cool, Dry	IA	Rural	End of manufacturer's recommended service life	O	O	O	O	O	O	O	O	O	Max start-to-discharge pressure = 15.7" W.C.		
256	Manufacturer B	2nd Stage	40	Cool, Dry	IA	Rural	End of manufacturer's recommended service life	O	O	O	O	O	O	O	O	O	Max lock-up = 16.8" W.C.		
257	Manufacturer B	2nd Stage	36	Cool, Dry	IA	Rural	End of manufacturer's recommended service life	O	O	O	O	O	O	O	O	O	Max lock-up = 14.2" W.C.; Max start-to-discharge = 33.8" W.C.		
262	Manufacturer A	2nd Stage	39	Cool, Dry	IA	Rural	End of manufacturer's recommended service life	O	O	O	O	O	O	O	O	O	Max start-to-discharge pressure = 33.5" W.C.		
263	Manufacturer A	2nd Stage	41	Cool, Dry	IA	Rural	End of manufacturer's recommended service life	O	O	O	O	O	O	O	O	O	Regulator bolts very rusty; Max start-to-discharge pressure = 42.6" W.C.		
268	Manufacturer B	2nd Stage	32	Cool, Dry	IA	Rural	End of manufacturer's recommended service life	O	O	O	O	O	O	O	O	O	Inlet end collecting fittings; difficult to remove; many coils of paint		
269	Manufacturer B	2nd Stage	16	Cool, Dry	IA	Rural	End of manufacturer's recommended service life	O	O	O	O	O	O	O	O	O	Pressure relief screen missing		
282	Manufacturer B	2nd Stage	42*	Cool, Dry	IA	Rural	End of manufacturer's recommended service life	O	O	O	O	O	O	O	O	O			
296	Manufacturer A	2nd Stage	9	Cool, Dry	SD	Rural	Tank and regulator removed from service at location	O	O	O	O	O	O	O	O	O			
312	Manufacturer A	2nd Stage	8	Cool, Damp	MI	Rural	Tank and regulator removed from service at location	O	O	O	O	O	O	O	O	O			
323	Manufacturer A	2nd Stage	18	Cool, Dry	SD	Rural	Tank and regulator removed from service at location	O	O	O	O	O	O	O	O	O			
343	Manufacturer A	2nd Stage	2	Warm, Dry	KY	Rural	Other	O	O	O	O	O	O	O	O	O	DID NOT TEST - Could not remove inlet fitting		
345	Manufacturer A	2nd Stage	4	Warm, Dry	KY	Rural	Other	O	O	O	O	O	O	O	O	O	Max lock-up = 13.9" W.C.; Max start-to-discharge pressure = 41.8" W.C.		
367	Manufacturer B	2nd Stage	39	Warm, Damp	WA	Urban	Tank and regulator removed from service at location	O	O	O	O	O	O	O	O	O	Max start-to-discharge pressure = 59" W.C.		
379	Manufacturer A	2nd Stage	47	Cool, Dry	SD	Rural	End of manufacturer's recommended service life	O	O	O	O	O	O	O	O	O			
415	Manufacturer A	2nd Stage	7	Warm, Dry	VA	Rural	Tank and regulator removed from service at location	O	O	O	O	O	O	O	O	O	Max start-to-discharge pressure = 34" W.C.		
444	Manufacturer B	2nd Stage	6	Warm, Damp	SC	Suburban	Tank and regulator removed from service at location	O	O	O	O	O	O	O	O	O			
445	Manufacturer B	2nd Stage	6	Warm, Dry	SC	Rural	Tank and regulator removed from service at location	O	O	O	O	O	O	O	O	O			
446	Manufacturer B	2nd Stage	6	Warm, Dry	SC	Rural	Tank and regulator removed from service at location	O	O	O	O	O	O	O	O	O			
462	Manufacturer B	2nd Stage	25	Cool, Dry	SD	Rural	End of manufacturer's recommended service life	O	O	O	O	O	O	O	O	O	Max start-to-discharge = 35.7" W.C. during test 1		
465	Manufacturer A	2nd Stage	41	Cool, Dry	WI	Urban	End of manufacturer's recommended service life	O	O	O	O	O	O	O	O	O	Regulator chatters and leaks through PRD at 30 cph and 10 psig inlet		
469	Manufacturer A	2nd Stage	30	Cool, Dry	WI	Urban	End of manufacturer's recommended service life	O	O	O	O	O	O	O	O	O	DID NOT TEST - Adjusting plate jammed into the bottom of the regulator		
472	Manufacturer A	2nd Stage	35	Cool, Dry	WI	Rural	End of manufacturer's recommended service life	O	O	O	O	O	O	O	O	O	Max start-to-discharge = 39" W.C.		
482	Manufacturer A	2nd Stage	25	Cool, Damp	IN	Rural	End of manufacturer's recommended service life	O	O	O	O	O	O	O	O	O	Max start-to-discharge pressure = 36.2" W.C.		
483	Manufacturer B	2nd Stage	20	Cool, Dry	IA	Rural	End of manufacturer's recommended service life	O	O	O	O	O	O	O	O	O	DID NOT TEST - Could not remove inlet fitting		
502	Manufacturer B	2nd Stage	25	Cool, Dry	IA	Rural	End of manufacturer's recommended service life	O	O	O	O	O	O	O	O	O	Very rusty; Max start-to-discharge pressure = 36.7" W.C.		
512	Manufacturer A	2nd Stage	4	Warm, Dry	VA	Rural	Tank and regulator removed from service at location	O	O	O	O	O	O	O	O	O	Max start-to-discharge pressure = 48.9" W.C.		
514	Manufacturer A	2nd Stage	11	Warm, Damp	VA	Rural	Tank and regulator removed from service at location	O	O	O	O	O	O	O	O	O			
520	Manufacturer B	2nd Stage	26	Cool, Damp	PA	Suburban	End of manufacturer's recommended service life	O	O	O	O	O	O	O	O	O	Low resetting pressures (11.8" W.C.)		
522	Manufacturer A	2nd Stage	31	Cool, Damp	PA	Suburban	End of manufacturer's recommended service life	O	O	O	O	O	O	O	O	O	DID NOT TEST - Adjusting plate and spring missing from regulator		
524	Manufacturer B	2nd Stage	31	Cool, Damp	PA	Suburban	End of manufacturer's recommended service life	O	O	O	O	O	O	O	O	O	Max start-to-discharge = 33.4" W.C.		
527	Manufacturer B	2nd Stage	31	Cool, Damp	PA	Suburban	End of manufacturer's recommended service life	O	O	O	O	O	O	O	O	O			
530	Manufacturer B	2nd Stage	25	Cool, Damp	PA	Suburban	End of manufacturer's recommended service life	O	O	O	O	O	O	O	O	O	Max start-to-discharge pressure = 34.2" W.C.		
531	Manufacturer B	2nd Stage	32	Cool, Damp	PA	Suburban	End of manufacturer's recommended service life	O	O	O	O	O	O	O	O	O			
533	Manufacturer A	2nd Stage	26	Cool, Damp	PA	Suburban	End of manufacturer's recommended service life	O	O	O	O	O	O	O	O	O			
534	Manufacturer A	2nd Stage	25	Cool, Damp	PA	Suburban	End of manufacturer's recommended service life	O	O	O	O	O							

Table 5. Overview of integral two-stage regulator performance.

REGULATOR INFORMATION										INSPECTIONS			LOCK-UP			PRESSURE RELIEF		REASON FOR FAILURE
Regulator ID	Regulator Manufacturer	Regulator Type	Regulator Age (Years)	Climate	Regulator Location State	Service Area	Reason for Regulator Removal	External Visual Inspection	Internal Inspection and Adjustment	Medium Inlet Pressure	Low Inlet Pressure	High Inlet Pressure	Start-to-Discharge Pressure	Reseating Pressure	REASON FOR FAILURE			
INTEGRAL 2-STAGE																		
13	Manufacturer A	Integral 2-Stage	13	Warm, Damp	AL	Rural	Fully regulator	○	○	○	○	○	○	○	○	Slow lock-up. Max Lock-up = 21.9" W.C.		
18	Manufacturer B	Integral 2-Stage	7	Cool, Damp	WA	Urban	Tank and regulator removed from service at location	○	○	○	○	○	○	○	○	Leak through PRD at 100 psig inlet pressure and high flow rate (80 cfm)		
54	Manufacturer A	Twin stage	7	Warm, Dry	KS	Rural	Fully regulator	○	○	○	○	○	○	○	○	Leak through regulator. Max Lock-up = 17" W.C.; PRD did not vent		
83	Manufacturer B	Integral 2-Stage	9	Cool, Dry	SD	Rural	Tank and regulator removed from service at location	○	○	○	○	○	○	○	○	Max inlet-to-discharge pressure = 33.7" W.C.		
106	Manufacturer B	Integral 2-Stage	11	Cool, Damp	AK	Rural	Fully regulator	○	○	○	○	○	○	○	○	Leak through regulator at 100 psig inlet pressure and 0 cfm (lock-up). Max Lock-up = 30.9" W.C.		
107	Manufacturer B	Integral 2-Stage	13	Cool, Damp	AK	Rural	Other upgrade	○	○	○	○	○	○	○	○	Slow lock-up. Max Lock-up = 15.4" W.C.		
108	Manufacturer B	Integral 2-Stage	11	Cool, Damp	AK	Rural	Other	○	○	○	○	○	○	○	○	Leak through PRD at 30 cfm and 100 psig inlet pressure		
116	Manufacturer B	Integral 2-Stage	10	Cool, Damp	WA	Suburban	Other	○	○	○	○	○	○	○	○	Leak through PRD at 30 cfm and 100 psig inlet pressure		
329	Manufacturer A	Integral 2-Stage	7	Cool, Dry	SD	Rural	Tank and regulator removed from service at location	○	○	○	○	○	○	○	○	Max Lock-up = 13.3" W.C.		
330	Manufacturer A	Twin Stage	7	Cool, Dry	SD	Rural	Tank and regulator removed from service at location	○	○	○	○	○	○	○	○	Max Lock-up = 13.3" W.C.		
339	Manufacturer B	Twin Stage	5	Cool, Damp	WA	Suburban	Tank and regulator removed from service at location	○	○	○	○	○	○	○	○	Inlet and outlet fittings rusty and difficult to remove		
340	Manufacturer B	Twin Stage	10	Cool, Damp	WA	Suburban	Tank and regulator removed from service at location	○	○	○	○	○	○	○	○	Leak through regulator when adjusting from 80 cfm to 30 cfm at 100 psig and 25 psig inlet pressures		
342	Manufacturer B	Twin Stage	4	Cool, Damp	WA	Suburban	Tank and regulator removed from service at location	○	○	○	○	○	○	○	○	Started to leak through the pressure relief at 250 psig inlet pressure		
347	Manufacturer B	Integral 2-Stage	13	Cool, Damp	AK	Rural	Fully regulator	○	○	○	○	○	○	○	○	Max start-to-discharge pressure = 34.4" W.C.		
348	Manufacturer B	Integral 2-Stage	1	Cool, Damp	AK	Rural	Other	○	○	○	○	○	○	○	○	Max start-to-discharge pressure = 34.4" W.C.		
354	Manufacturer B	Integral 2-Stage	5	Warm, Dry	CA	Rural	Tank and regulator removed from service at location	○	○	○	○	○	○	○	○	Regulator leaks through PRD at 30 cfm and 100 psig inlet		
475	Manufacturer B	Combo	11	Warm, Dry	NJ	Suburban	Tank and regulator removed from service at location	○	○	○	○	○	○	○	○	Leak through PRD at 0.5 cfm and 250 psig inlet		
476	Manufacturer B	Combo	13	Warm, Dry	NJ	Urban	End of manufacturer's recommended service life	○	○	○	○	○	○	○	○	PRD reseating pressure = 18.2" W.C.		
477	Manufacturer B	Combo	9	Warm, Dry	NJ	Suburban	Tank and regulator removed from service at location	○	○	○	○	○	○	○	○	Regulator chatters, leaks through PRD at 30 cfm and 100 psig inlet		
490	Manufacturer B	Integral 2-Stage*	6	Warm, Damp	FL	Suburban	Changed from single to dual regulator system	○	○	○	○	○	○	○	○	Regulator chatters, leaks through PRD at 30 cfm and 100 psig inlet		
637	Manufacturer B	Combo	28	Warm, Dry	NJ	Rural	Fully regulator; leaks	○	○	○	○	○	○	○	○	Max start-to-discharge pressure = 36.7" W.C.		

KEY																
EXTERNAL INSPECTION																
○	Regulator in good condition; no visible sign of a problem															
△	Regulator shows signs of corrosion, wear, stiff/frozen springs, slow to reach setpoint, etc. but still tested															
×	Regulator missing essential components (bonnet cap; outer screws, etc.)															
○	Regulator in good condition; no visible sign of a problem															
△	Regulator shows signs of corrosion, wear, stiff/frozen springs, slow to reach setpoint, etc. but still tested															
×	Cannot set initial pressure during regulator adjustment; pressure fluctuates and/or never reaches setpoint															
×	Regulator leaked through PRD during adjustment															
○	Regulator meets lock-up criteria for a new regulator as specified in UL 144															
○	Regulator did not meet UL 144 lock-up criteria for a new regulator in 1 out of 3 trials but locked-up lower than the pressure relief start-to-discharge (UL 144 < Lock-up < PRD std)															
○	Regulator did not meet UL 144 lock-up criteria for a new regulator in 2 out of 3 trials but locked-up lower than the pressure relief start-to-discharge (UL 144 < Lock-up < PRD std)															
○	Regulator did not meet UL 144 lock-up criteria for a new regulator in 3 out of 3 trials but locked-up lower than the pressure relief start-to-discharge (UL 144 < Lock-up < PRD std)															
○	Regulator leaked through PRD during lock-up testing (PRD std < Lock-up)															
○	Regulator meets pressure relief start-to-discharge and reseating criteria for a new regulator as specified in UL 144															
○	Regulator did not meet UL 144 pressure relief start-to-discharge and reseating criteria for a new regulator in 1 out of 3 trials (usually occurred on the first trial)															
○	Regulator did not meet UL 144 pressure relief start-to-discharge and reseating criteria for a new regulator in 2 out of 3 trials (usually occurred on the first trial)															
○	Regulator did not meet UL 144 pressure relief start-to-discharge and reseating criteria for a new regulator in 3 out of 3 trials (usually occurred on the first trial)															
*	Reason for regulator removal marked is inconsistent with the manufacturer's date stamp															
**	The type of regulator marked is inconsistent with the reason for removal															
†	Tests not conducted															
	Pressure relief device did not vent															

Table 6. Overview of single-stage regulator performance.

REGULATOR INFORMATION										INSPECTIONS			LOCK-UP			PRESSURE RELIEF		REASON FOR FAILURE
Regulator ID	Regulator Manufacturer	Regulator Type	Regulator Age (Years)	Climate	Regulator Location State	Service Area	Reason for Regulator Removal	External Visual Inspection	Internal Inspection and Adjustment	Medium Inlet Pressure	Low Inlet Pressure	High Inlet Pressure	Start-to-Discharge Pressure	Reseating Pressure	REASON FOR FAILURE			
SINGLE STAGE REGULATORS																		
38	Manufacturer A	Single	37	Cool, Dry	IA	Rural	End of manufacturer's recommended service life	○	○	○	○	○	○	○	○	Adjusting spring frozen; low outlet pressures		
55	Manufacturer A	Single	15	Warm, Dry	KS	Rural	Changed from single to dual regulator system	○	○	○	○	○	○	○	○	Leak through PRD at 30 cfm and 100 psig inlet		
67	Manufacturer A	Single	27	Cool, Damp	OH	Rural	Tank and regulator removed from service at location	○	○	○	○	○	○	○	○	Max start-to-discharge = 35.4" W.C.		
81	Manufacturer A	Single	13	Cool, Dry	SD	Rural	Tank and regulator removed from service at location	○	○	○	○	○	○	○	○	Regulator chatters, leaks through PRD at high flow rates; std = 10.2" W.C.		
85	Manufacturer A	Single	20	Cool, Dry	SD	Rural	Tank and regulator removed from service at location	○	○	○	○	○	○	○	○	Regulator chatters, leaks through PRD at high flow rates; std = 10.2" W.C.		
91	Manufacturer A	Single	16	Cool, Dry	SD	Rural	Tank and regulator removed from service at location	○	○	○	○	○	○	○	○	Leak through PRD at high flow rate (80 cfm); std = 13.7" W.C.		
92	Manufacturer A	Single	16	Cool, Dry	SD	Rural	Tank and regulator removed from service at location	○	○	○	○	○	○	○	○	Stiff adjusting spring; Max start-to-discharge = 33.5" W.C.		
97	Manufacturer A	Single	11	Cool, Dry	SD	Rural	Tank and regulator removed from service at location	○	○	○	○	○	○	○	○	Max Lock-up = 13.8" W.C.		
98	Manufacturer A	Single	18	Cool, Dry	SD	Rural	Tank and regulator removed from service at location	○	○	○	○	○	○	○	○	Max Lock-up = 17.8" W.C.		
150	Manufacturer A	Single	13	Warm, Dry	MS	Rural	Changed from single to dual regulator system	○	○	○	○	○	○	○	○	Missing bonnet cap; maximum lock-up 14" W.C. during the 100 psig inlet test. All other tests performed within the UL criteria		
161	Manufacturer A	Single	23	Warm, Damp	MS	Rural	Tank and regulator removed from service at location	○	○	○	○	○	○	○	○	Max Lock-up = 17.8" W.C.		
182	Manufacturer B	Single	19	Warm, Damp	MS	Rural	Tank and regulator removed from service at location	○	○	○	○	○	○	○	○	Could not adjust regulator down to 11" W.C.		
188	Manufacturer A	Single	54	Warm, Damp	MS	Rural	Tank and regulator removed from service at location	○	○	○	○	○	○	○	○	Max Lock-up = 17.8" W.C.		
193	Manufacturer B	Single	42	Warm, Damp	MS	Rural	Tank and regulator removed from service at location	○	○	○	○	○	○	○	○	Max Lock-up = 17.8" W.C.		
197	Manufacturer A	Single	18	Warm, Dry	MS	Rural	End of manufacturer's recommended service life	○	○	○	○	○	○	○	○	Regulator chattered and leaked through the PRD at 100 psig and 80 cfm then stopped; PRD max start-to-discharge = 39.2" W.C.		
199	Manufacturer A	Single	15	Warm, Dry	MS	Rural	End of manufacturer's recommended service life	○	○	○	○	○	○	○	○	Could not adjust regulator down to 11" W.C.		
201	Manufacturer A	Single	40	Warm, Dry	MS	Rural	End of manufacturer's recommended service life	○	○	○	○	○	○	○	○	Max Lock-up = 20.0" W.C.; Regulator chattered and leaked through the PRD at 100 psig and 80 cfm then stopped; PRD max start-to-discharge = 39.2" W.C.		
203	Manufacturer A	Single	11*	Warm, Dry	MS	Rural	End of manufacturer's recommended service life	○	○	○	○	○	○	○	○	Regulator chattered and leaked through the PRD at 100 psig and 80 cfm then stopped; PRD max start-to-discharge = 39.2" W.C.		
226	Manufacturer A	Single	11	Cool, Dry	SD	Rural	Tank and regulator removed from service at location	○	○	○	○	○	○	○	○	Adjusting screw at the way down; low outlet pressures		
231	Manufacturer A	Single	22	Cool, Dry	SD	Rural	Tank and regulator removed from service at location	○	○	○	○	○	○	○	○	Adjusting screw at the way down; low outlet pressures		
238	Manufacturer B	Single	55	Cool, Dry	SD	Rural	Tank and regulator removed from service at location	○	○	○	○	○	○	○	○	Max Lock-up = 18.2" W.C.; pressure relief screen missing		
241	Manufacturer B	Single	7	Cool, Dry	SD	Rural	Tank and regulator removed from service at location	○	○	○	○	○	○	○	○	Max start-to-discharge = 34.33" W.C.		
292	Manufacturer A	Single	27	Cool, Dry	SD	Rural	Tank and regulator removed from service at location	○	○	○	○	○	○	○	○	Leak through regulator. Max Lock-up = 34.4" W.C.		
313	Manufacturer A	Single	16	Warm, Dry	MS	Rural	Tank and regulator removed from service at location	○	○	○	○	○	○	○	○	Rusty inlet fitting; gasket broken around spring cover		
353	Manufacturer A	Single	15	Warm, Damp	MS	Rural	End of manufacturer's recommended service life	○	○	○	○	○	○	○	○	Pressure relief screen missing; slow lock-up; Max start-to-discharge = 33.9" W.C.; Max Lock-up = 18" W.C.		
358	Manufacturer B	Single	28	Warm, Dry	CA	Rural	End of manufacturer's recommended service life	○	○	○	○	○	○	○	○	Max start-to-discharge = 43" W.C.; Max lock-up = 23.3" W.C.		
360	Manufacturer B	Single	50	Warm, Dry	CA	Rural	End of manufacturer's recommended service life	○	○	○	○	○	○	○	○	Regulator chatters, leaks through PRD at 30 cfm		
362	Manufacturer B	Single	13	Warm, Dry	CA	Rural	Tank and regulator removed from service at location	○	○	○	○	○	○	○	○	Regulator chatters, leaks through PRD at 30 cfm		
374	Manufacturer B	Single	20	Cool, Dry	SD	Rural	Tank and regulator removed from service at location	○	○	○	○	○	○	○	○	Regulator outlet pressure will not hold steadily		
383	Manufacturer B	Single	43	Cool, Dry	SD	Rural	Tank and regulator removed from service at location	○	○	○	○	○	○	○	○	Slow lock-up; Max Lock-up = 30.3" W.C.		
397	Manufacturer A	Single	23	Warm, Dry	AZ	Rural	Tank and regulator removed from service at location	○	○	○	○	○	○	○	○	Max Lock-up = 35.7" W.C.; Max start-to-discharge = 38" W.C.		
400	Manufacturer A	Single	16	Warm, Dry	SC	Rural	Changed from single to dual regulator use	○	○	○	○	○	○	○	○	Regulator will not lock-up; max pressure before test stopped = 13.7" W.C.		
407	Manufacturer A	Single	12	Warm, Dry	SC	urban	Tank and regulator removed from service at location	○	○	○	○	○	○	○	○	Regulator leaked through PRD at 30 cfm		
								○	○	○	○	○	○	○	○	Max Lock-up = 13.8" W.C.; Max start-to-discharge = 33.3" W.C.		

KEY																
EXTERNAL INSPECTION																
○	Regulator in good condition; no visible sign of a problem															
△	Regulator shows signs of corrosion, wear, etc. but still tested															
×	Regulator missing essential components (bonnet cap; outer screws, etc.)															
○	Regulator in good condition; no visible sign of a problem															
△	Regulator shows signs of corrosion, wear, stiff/frozen springs, slow to reach setpoint, etc. but still tested															
×	Cannot set initial pressure during regulator adjustment; pressure fluctuates and/or never reaches setpoint															
×	Regulator leaked through PRD during adjustment															
○	Regulator meets lock-up criteria for a new regulator as specified in UL 144															
○	Regulator did not meet UL 144 lock-up criteria for a new regulator in 1 out of 3 trials but locked-up lower than the pressure relief start-to-discharge (UL 144 < Lock-up < PRD std)															
○	Regulator did not meet UL 144 lock-up criteria for a new regulator in 2 out of 3 trials but locked-up lower than the pressure relief start-to-discharge (UL 144 < Lock-up < PRD std)															
○	Regulator did not meet UL 144 lock-up criteria for a new regulator in 3 out of 3 trials but locked-up lower than the pressure relief start-to-discharge (UL 144 < Lock-up < PRD std)															
○	Regulator leaked through PRD during lock-up testing (PRD std < Lock-up)															
○	Regulator meets pressure relief start-to-discharge and reseating criteria for a new regulator as specified in UL 144															
○	Regulator did not meet UL 144 pressure relief start-to-discharge and reseating criteria for a new regulator in 1 out of 3 trials (usually occurred on the first trial)															
○	Regulator did not meet UL 144 pressure relief start-to-discharge and reseating criteria for a new regulator in 2 out of 3 trials (usually occurred on the first trial)															
○	Regulator did not meet UL 144 pressure relief start-to-discharge and reseating criteria for a new regulator in 3 out of 3 trials (usually occurred on the first trial)															
*	Reason for regulator removal marked is inconsistent with the manufacturer's date stamp															
**	The type of regulator marked is inconsistent with the reason for removal															
†	Tests not conducted															
	Pressure relief device did not vent															

This page intentionally left blank.

5.3.1 Summary of Lock-up Test Results

Regulator lock-up was measured at three different inlet pressures and recorded in three successive trials for each inlet pressure. For first-stage, integral two-stage, and single-stage regulators lock-up was measured at 100 psig, 25 psig, and 250 psig inlet pressures while lock-up for second-stage regulators was recorded at 10 psig, 5 psig, and 15 psig inlet pressures. Figures 22 through 39 compare the outlet pressure at lock-up to the test criteria and age for the regulators tested in this program.

First-Stage Regulators

Figures 22 through 30 compare the lock-up pressures to the test criteria and age for the first-stage regulators tested in this program (includes 10 psi, 5 psi, and 15 psi set regulators). Discussion of the first-stage regulator results is primarily focused on the 10 psi regulators as these regulators comprised the majority of the first-stage regulator samples collected. Only two 5-psi regulators and twenty-one 15 psi regulators were received for testing. The results for these regulators are shown in Figures 25 through 30. A general overview of first-stage regulator performance is provided in Table 3 of the previous section.

The results show that the lock-up test performance of first-stage regulators remains fairly consistent between regulators regardless of age and for the most part remains within the UL 144 criteria for new regulators.

Only three of the regulators exceeded the UL 144 test criteria for new regulators at 100 psig inlet pressure and ranged in age from 14 to 41 years. These same regulators that did not meet the UL 144 criteria for new regulators were from three different environmental conditions and two different manufacturers. Based on these charts, there does not appear to be a significant correlation between regulator performance and age, environment, or manufacturer for first-stage regulators. One regulator supplied by the marketers was listed as a faulty regulator. Details for the regulators that did not meet the UL 144 criteria for new regulators are provided in Table 7. It should be noted that Figures 22 through 30 do not show regulators that failed to perform during adjustment. These regulators are discussed further in Section 5.3.5.

Table 7. First-stage regulators that did not meet the UL 144 lock-up criteria for new regulators.

Regulator ID	Manuf.	Age	Climate	State	Service Area	Reason for Removal	Reason for Not Meeting UL Criteria
267	B	41	Cool, Dry	IA	Rural	End of manuf. recom. service life	Outlet pressure would not stabilize; high lock-up
275	A	47	Cool, Dry	IA	Rural	End of manuf. recom. service life	Leak through regulator; pressure continued to climb
474	B	16	Warm, Dry	NJ	Suburban	End of manuf. recom. service life	High lock-up
538	A	16	Warm, Dry	PA	Suburban	Tank and regulator removed from service	Leak through PRD at 25 psi inlet pressure
593	A	17	Cool, Damp	ME	Rural	Tank and regulator removed from service	Slow lock-up at 100 psi inlet pressure
614	A	22	Cool, Dry	IA	Rural	End of manuf. recom. service life	High lock-up
783	B	14	Warm, Damp	MS	--	Faulty regulator	Outlet pressure would not stabilize; high lock-up

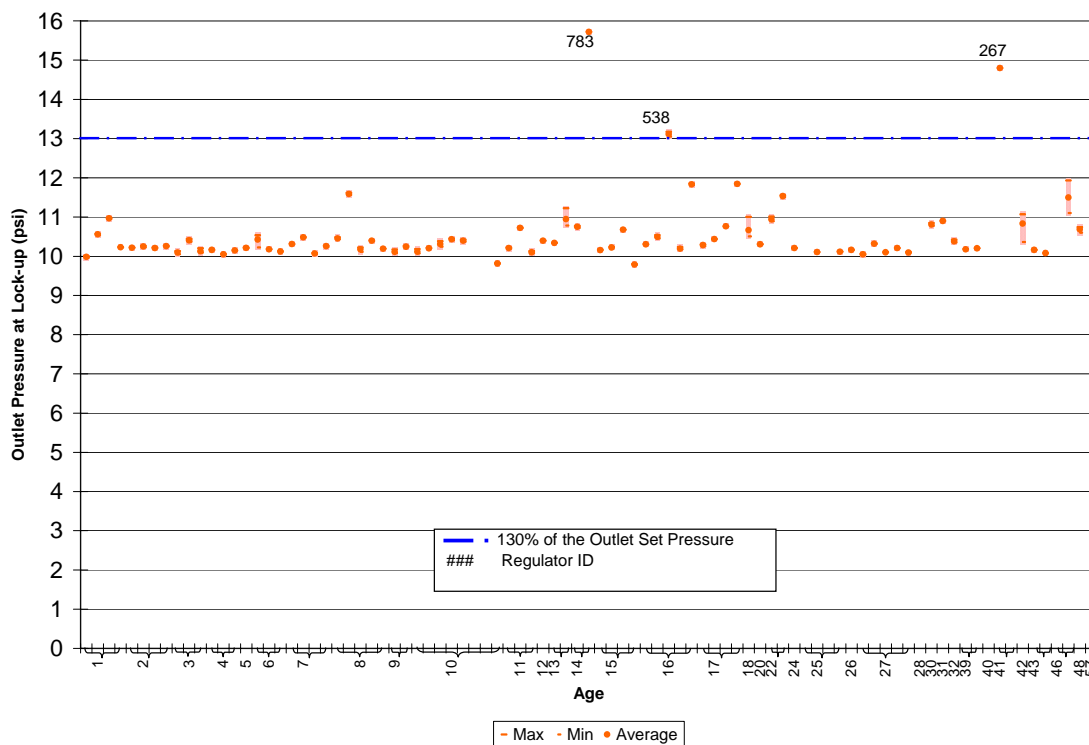

Figure 22. Lock-up pressures and age for 10 psi first-stage regulators at 100 psig inlet pressure.

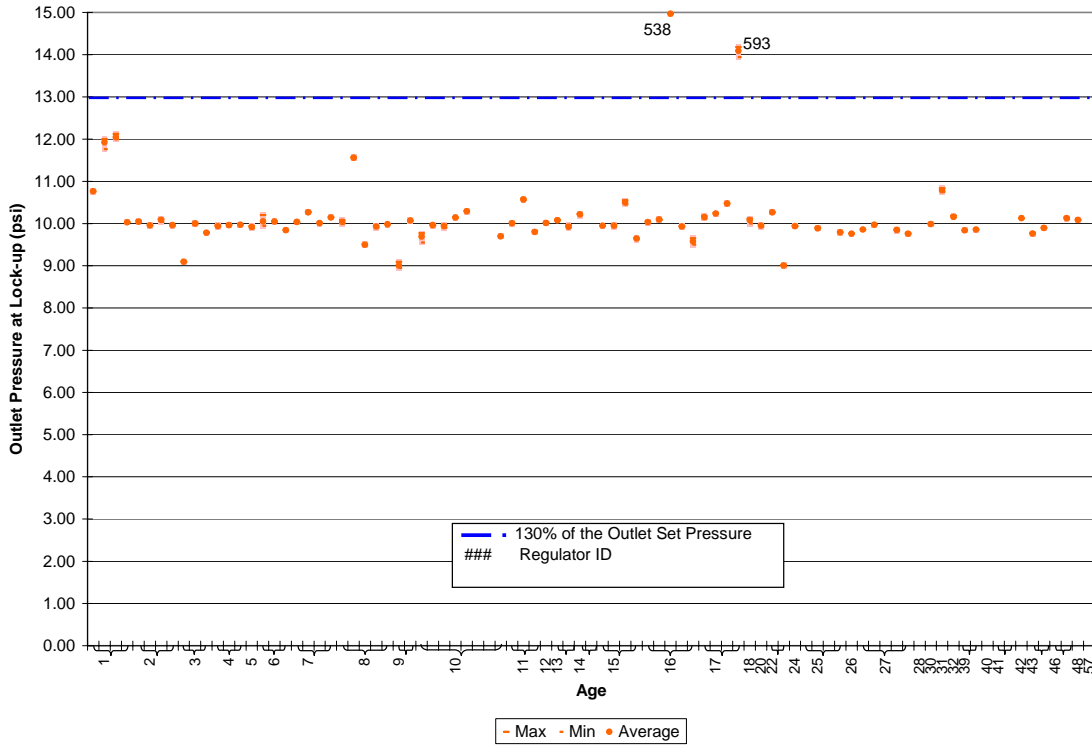

Figure 23. Lock-up pressures and age for 10 psi first-stage regulators at 25 psig inlet pressure.

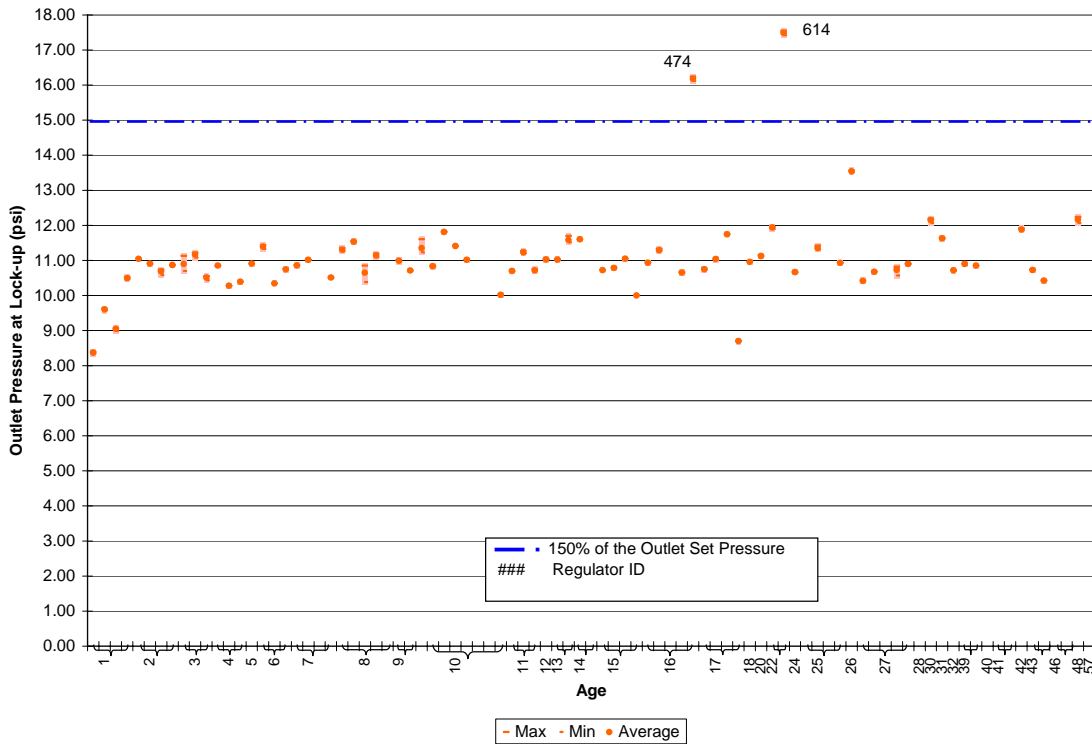

Figure 24. Lock-up pressures and age for 10 psi first-stage regulators at 250 psig inlet pressure.

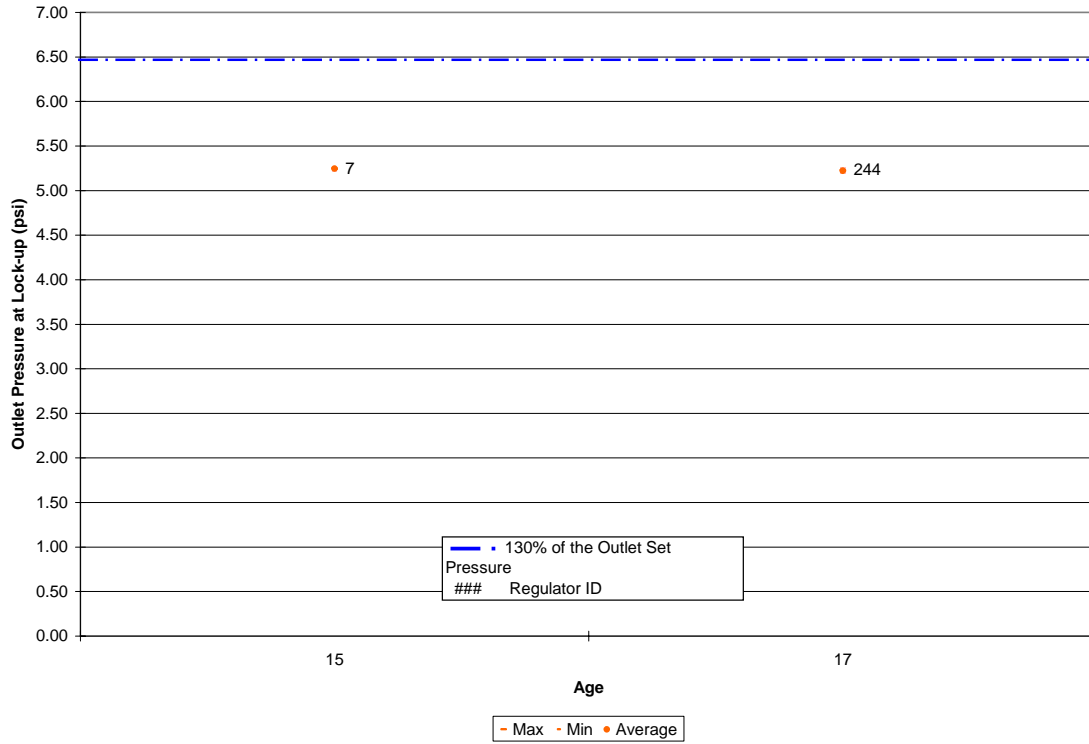

Figure 25. Lock-up pressures and age for 5 psi first-stage regulators at 100 psig inlet pressure.

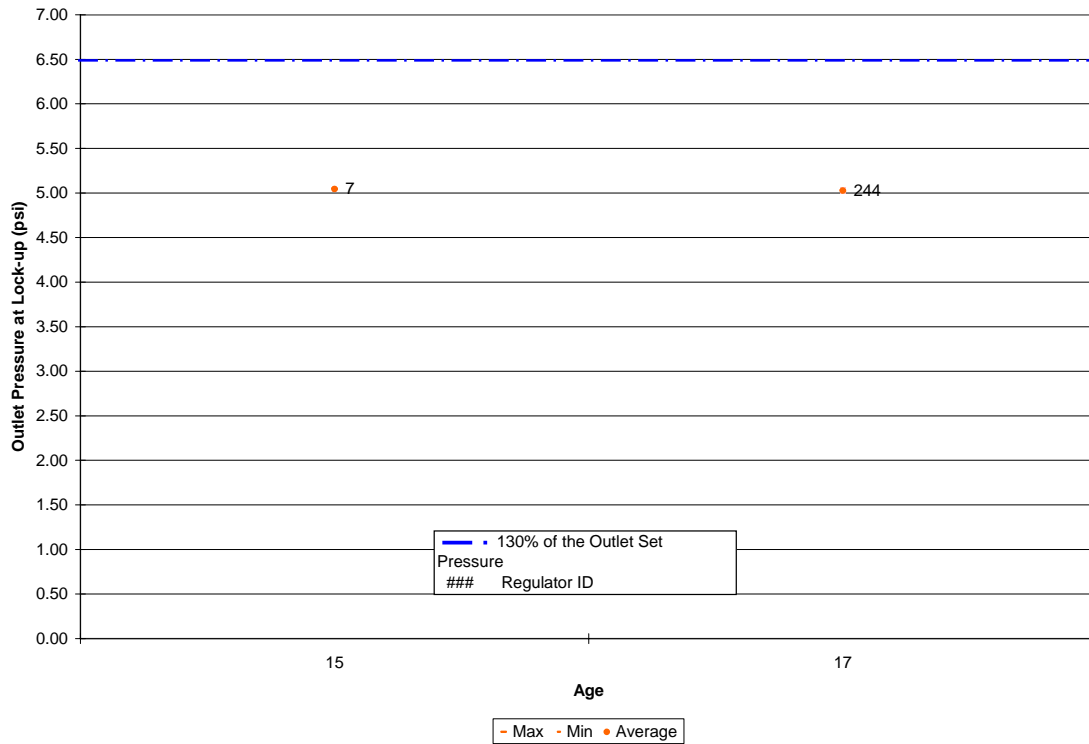

Figure 26. Lock-up pressures and age for 5 psi first-stage regulators at 25 psig inlet pressure.

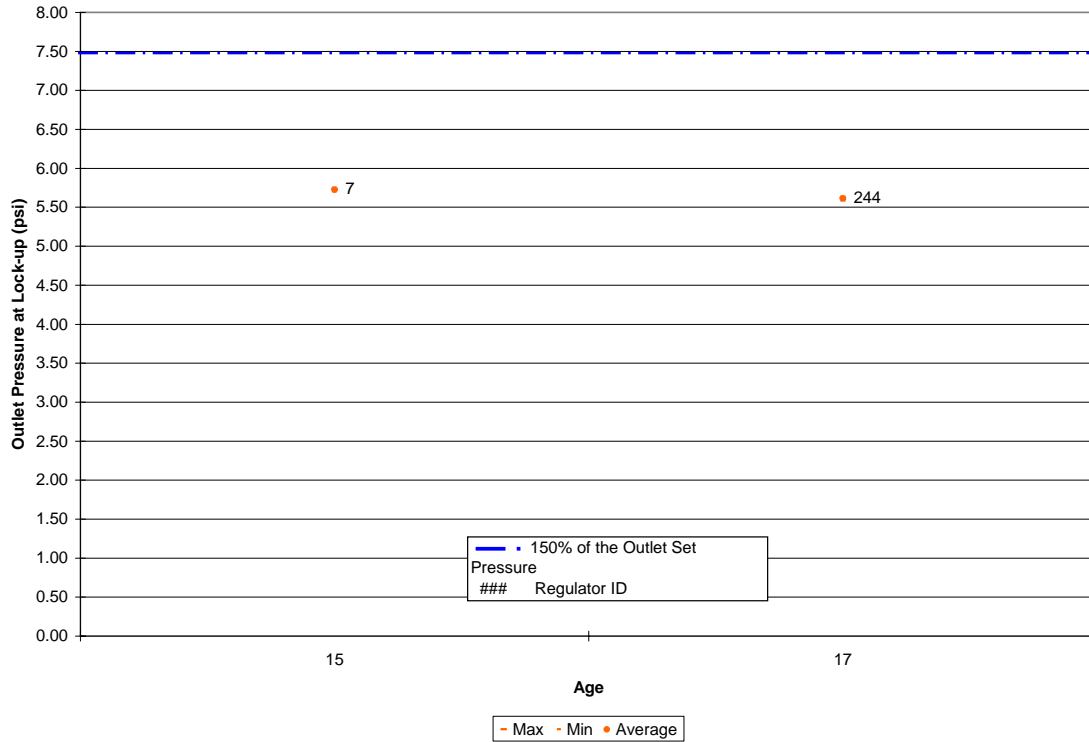

Figure 27. Lock-up pressures and age for 5 psi first-stage regulators at 250 psig inlet pressure.

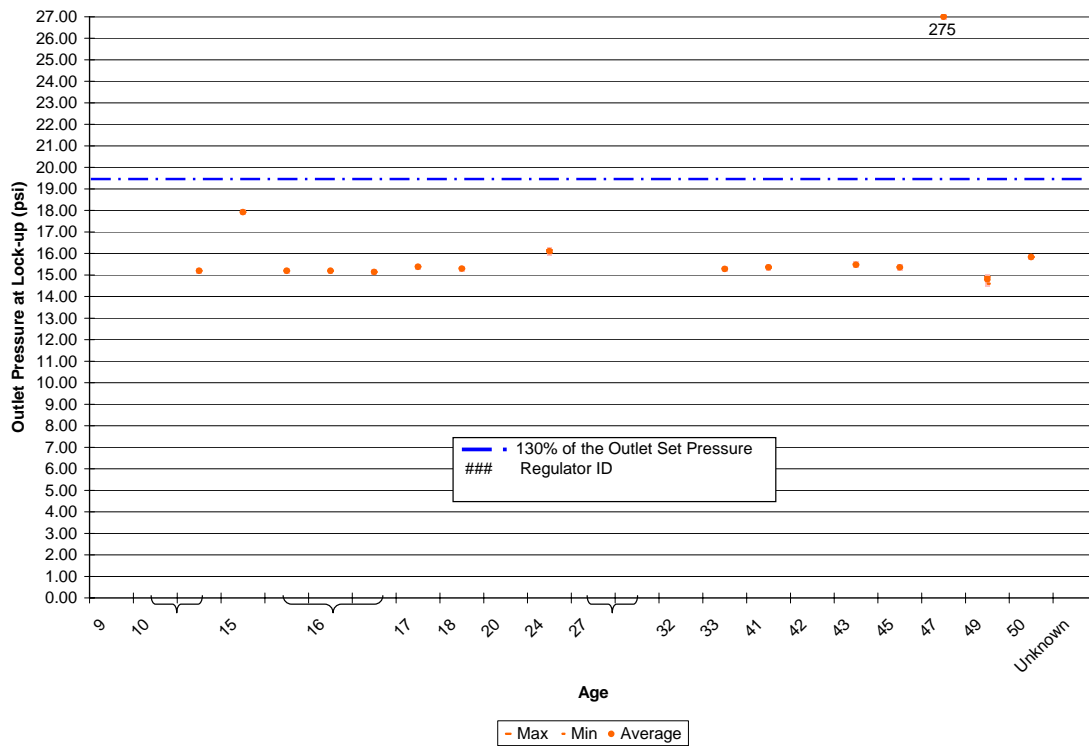

Figure 28. Lock-up pressures and age for 15 psi first-stage regulators at 100 psig inlet pressure.

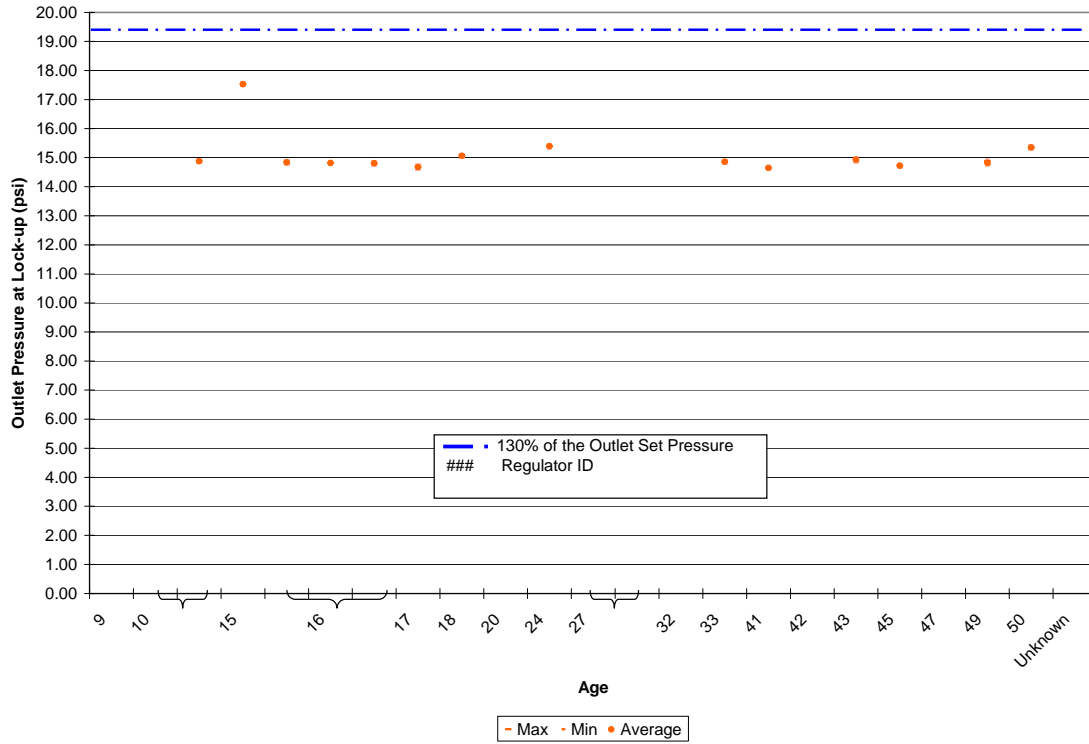

Figure 29. Lock-up pressures and age for 15 psi first-stage regulators at 25 psig inlet pressure.

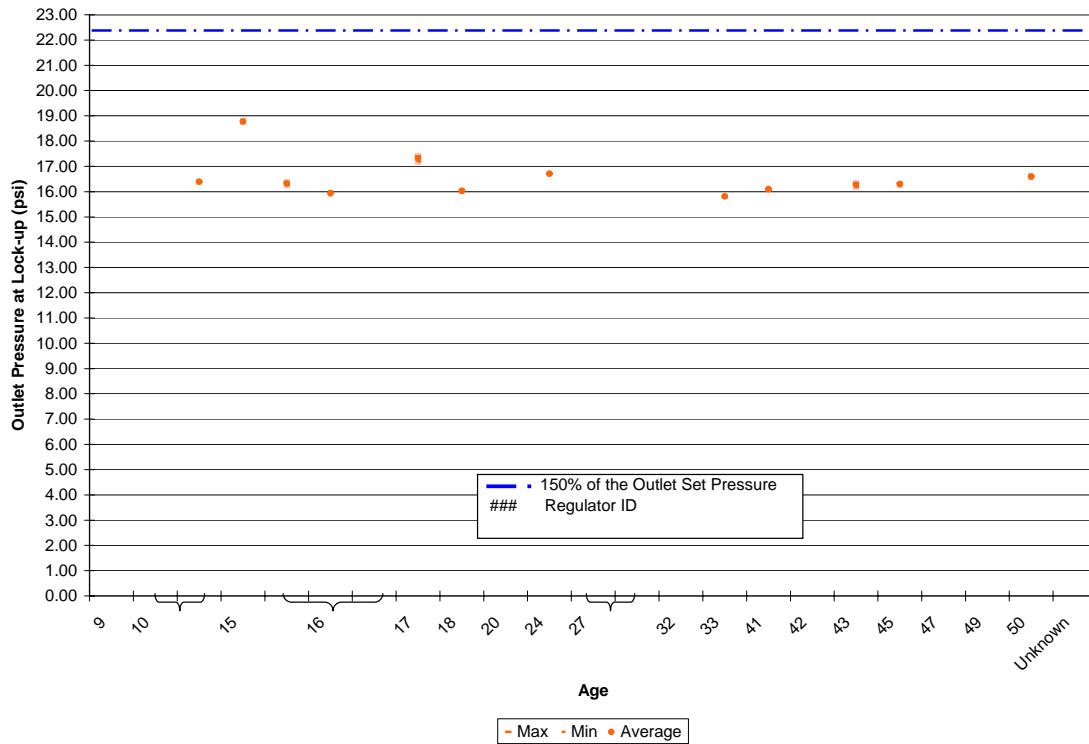

Figure 30. Lock-up pressures and age for 15 psi first-stage regulators at 250 psig inlet pressure.

Second-Stage Regulators

A general overview of all second-stage regulators tested in this program was provided in Table 4. Figures 31 through 33 compare the lock-up pressures to the test criteria and age for the second-stage regulators tested in this program. Note that regulators that failed to perform during adjustment are not included in these figures, but are addressed in Section 5.3.5.

The performance of second-stage regulators was more scattered than for the first-stage regulators, with the number of regulators not meeting the test criteria showing an increase past 35 years of age.

Ten second-stage regulators did not meet the UL 144 lock-up criteria for new regulators, tending to increase significantly past 35 years of age. Six regulators that did not meet the UL 144 criteria were from a cool, dry environment; however, this may be because a larger sample size from this environment was received for testing. Additionally, six of the regulators with lock-up that did not meet the UL 144 criteria were from Manufacturer B. Details for the regulators that did not meet the UL 144 criteria for new regulators are provided in Table 8.

Table 8. Second-stage regulators that did not meet the UL 144 lock-up criteria for new regulators.

Regulator ID	Manuf.	Age	Climate	State	Service Area	Reason for Removal	Reason for Not Meeting UL Criteria
42	B	16	Warm, Dry	IL	Suburban	End of manuf. recom. service life	High lock-up pressure
47	A	--	Cool, Dry	SD	Rural		High lock-up pressure; regulator chatters
68	B	13	Cool, Damp	OH	Suburban	Tank and regulator removed from service	High lock-up pressure; high PRD start-to-discharge pressure
90	B	46	Cool, Dry	SD	Rural	Tank and regulator removed from service	High lock-up pressure; pressure would not stabilize
100	D	44	Cool, Dry	PA	Suburban	Service work at customer location and found old regulator	Very rusty; high lock-up pressure
228	B	47	Cool, Dry	SD	Rural	Tank and regulator removed from service	High lock-up pressure; high PRD start-to-discharge pressure
256	B	40	Cool, Dry	IA	Rural	End of manuf. recom. service life	Dirty inside regulator; High lock-up pressure; Leak through regulator
257	B	36	Cool, Dry	IA	Rural	End of manuf. recom. service life	High lock-up pressure
345	A	4	Warm, Dry	KY	Rural	Other	High lock-up pressure; high PRD start-to-discharge pressure
534	A	25	Cool, Damp	PA	Suburban	End of manuf. recom. service life	High lock-up pressure

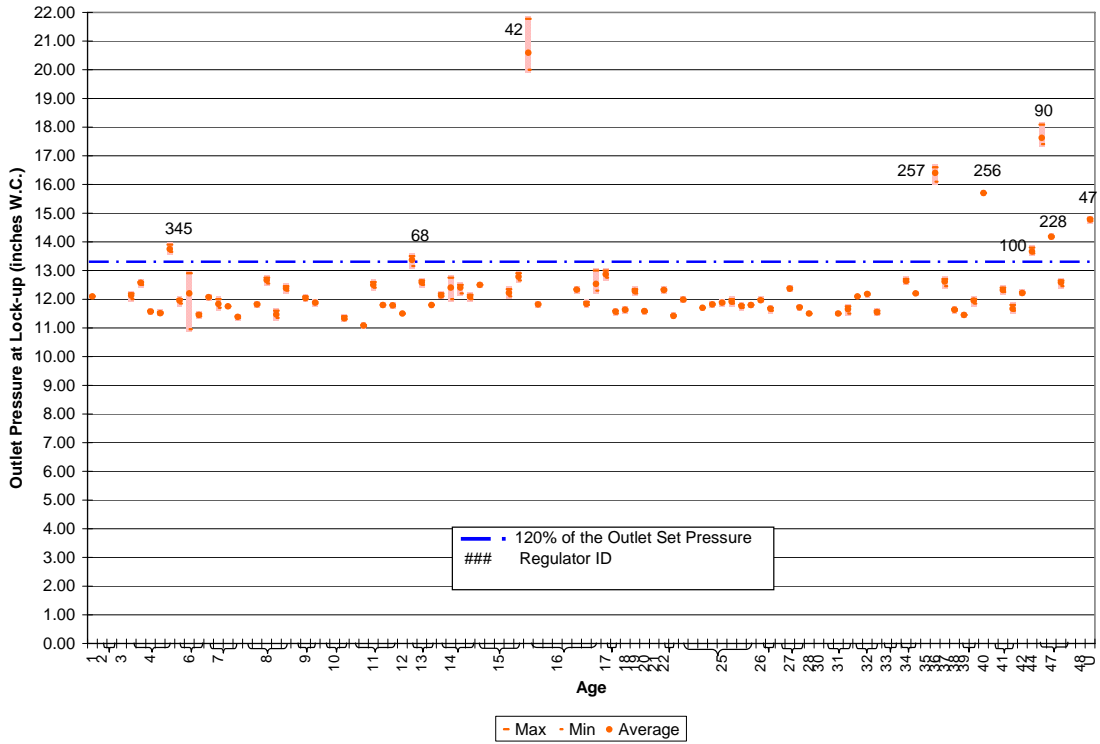

Figure 31. Lock-up pressures and age for second-stage regulators at 10 psig inlet pressure.

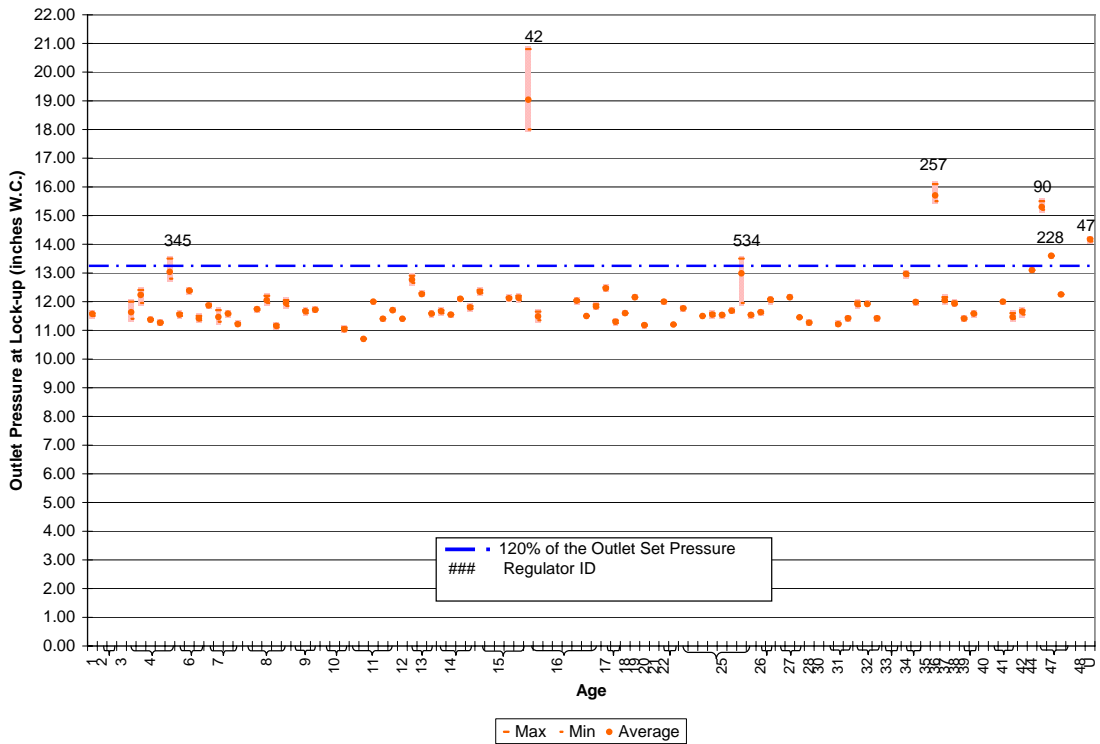

Figure 32. Lock-up pressures and age for second-stage regulators at 5 psig inlet pressure.

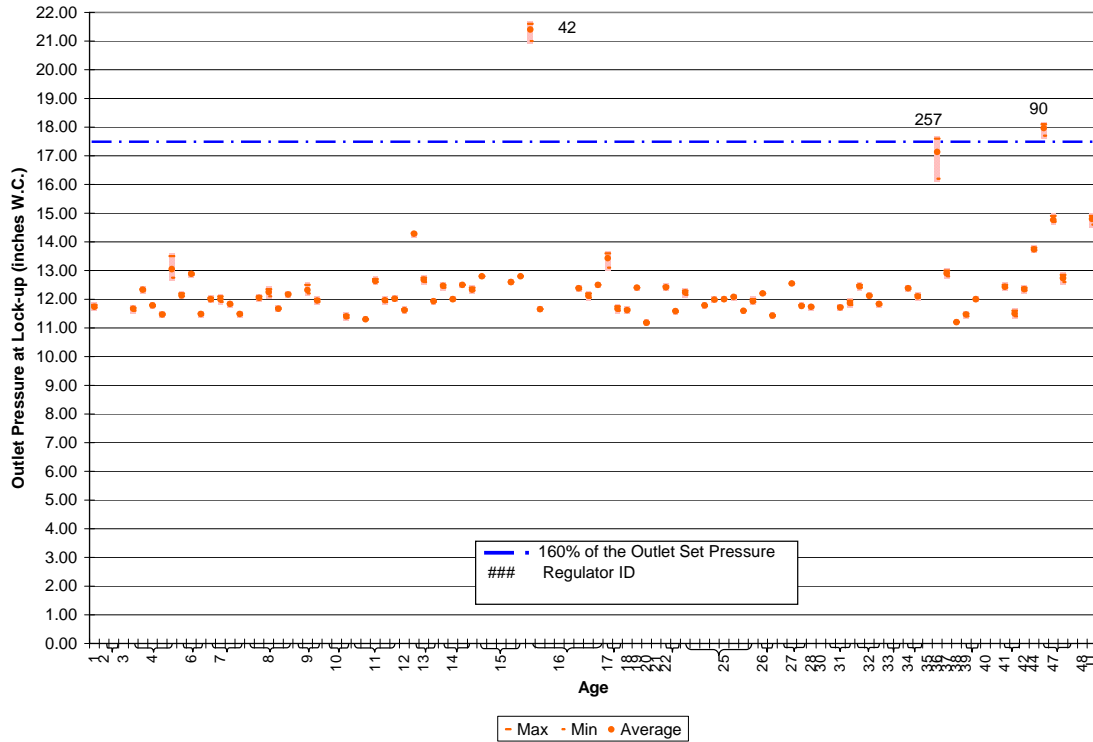

Figure 33. Lock-up pressures and age for second-stage regulators at 15 psig inlet pressure.

Integral Two-Stage Regulators

Figures 34 through 36 compare the lock-up pressures to the test criteria and age for the integral two-stage regulators tested in this program. The performance of the integral two-stage regulators from the small sample size received for this program was marginal. Of the 17 two-stage regulators to undergo lock-up testing five regulators during the 100 psig inlet pressure test did not meet the UL 144 criteria for new regulators. The percentage of two-stage regulators not meeting the UL 144 criteria for lock-up is significantly higher than that for both first- and second-stage regulators. Three of the five regulators that did not meet the lock-up test criteria were listed as faulty regulators by the marketer. There does not appear to be a trend in environmental location or manufacturers for the two-stage regulators that did not meet the test criteria. Details for the regulators that did not meet the test criteria are provided in Table 9.

It should be noted that Figures 34 through 36 do not show regulators that failed to perform during adjustment. These regulators are discussed further in Section 5.3.5. A general overview of integral two-stage regulator performance is provided in Table 5.

Table 9. Integral two-stage regulators that did not meet the UL 144 lock-up criteria for new regulators.

Regulator ID	Manuf.	Age	Climate	State	Service Area	Reason for Removal	Reason for Not Meeting UL Criteria
13	A	13	Warm, Damp	AL	Rural	Faulty regulator	High lock-up pressure
54	A	7	Warm, Dry	KS	Rural	Faulty regulator	High lock-up pressure; PRD did not relieve
107	B	13	Cool, Damp	AK	Rural	Faulty regulator	Leak through regulator
108	B	11	Cool, Damp	AK	Rural	Other: upgrade	High lock-up pressure
330	A	5	Cool, Dry	SD	Rural	Tank and regulator removed from service	High lock-up pressure

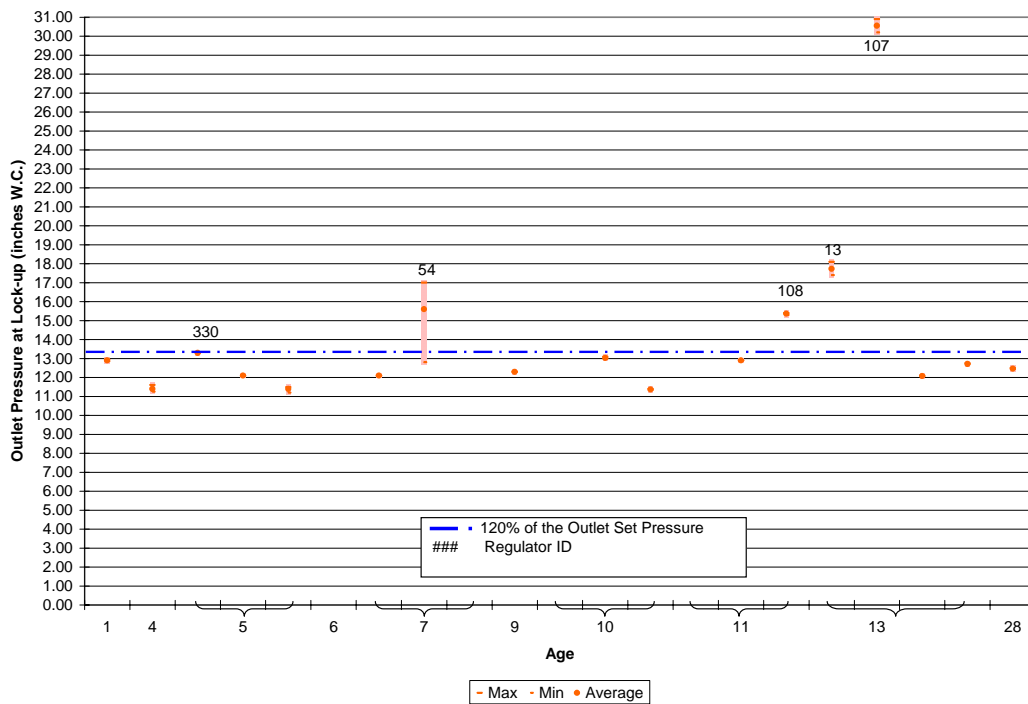

Figure 36. Lock-up pressures and age for integral two-stage regulators at 100 psig inlet pressure.

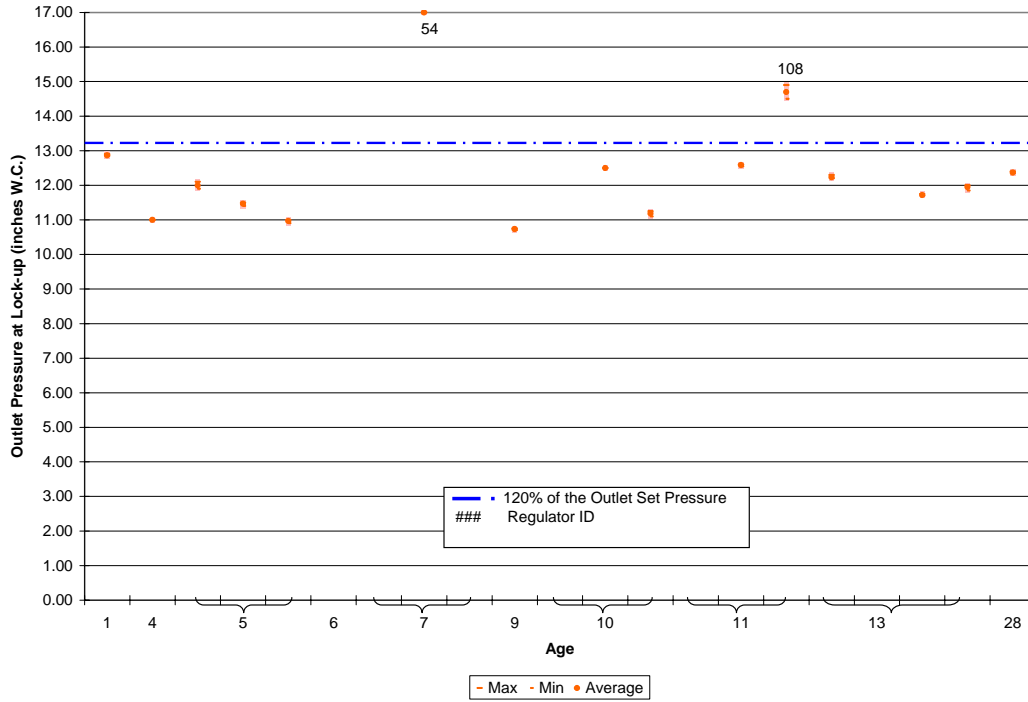

Figure 35. Lock-up pressures and age for integral two-stage regulators at 25 psig inlet pressure.

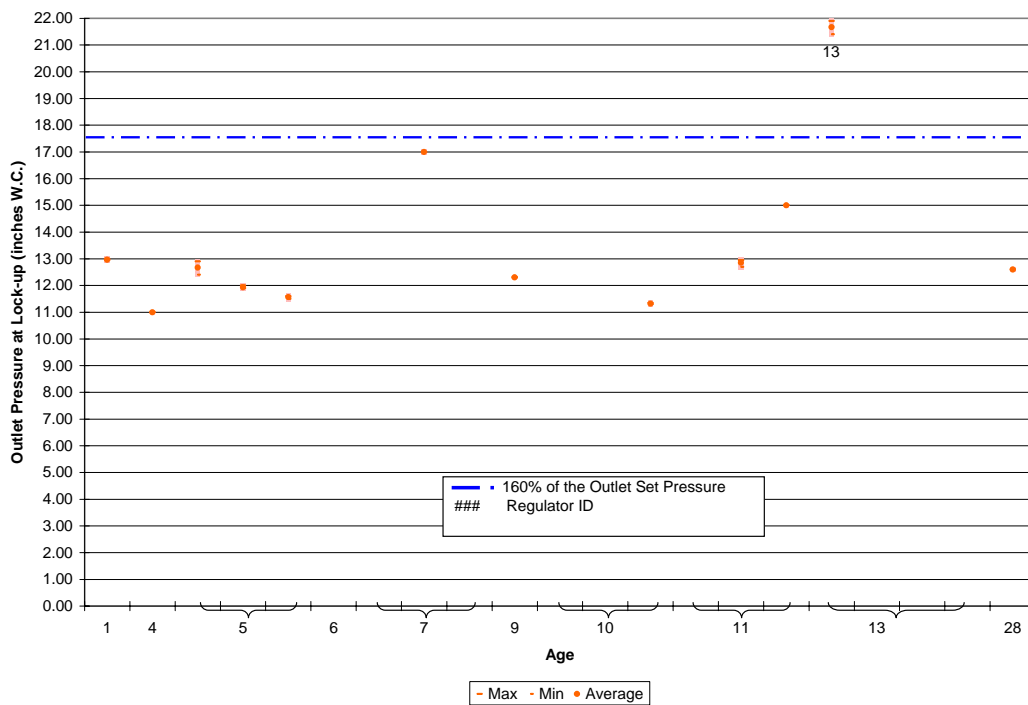

Figure 36. Lock-up pressures and age for integral two-stage regulators at 250 psig inlet pressure.

Single-Stage Regulators

Figures 37 through 39 compare the lock-up pressures to the test criteria and age for the single-stage regulators tested in this program. The performance of single-stage regulators during the lock-up testing was poor. Of the 23 single-stage regulators to undergo lock-up testing 17 regulators during the 100 psig inlet pressure test did not meet the UL 144 criteria for new regulators. The percentage of single-stage regulators that did not meet the test criteria far exceeded the lock-up tests for the other regulator types. There appears to be a trend in the deterioration of regulator performance as related to age; although single-stage regulators of all ages did not perform well. There does not appear to be a significant trend in regulator performance as related to environmental location or manufacturer for single-stage regulators. More regulators from Manufacturer A did not meet the test criteria; however a larger sample of regulators from this manufacturer were tested. Details for the single-stage regulators that did not meet the test criteria are provided in Table 10.

Initially, regulators for testing were selected from all types (first-stage, second-stage, single-stage, and integral two-stage) that were provided for this study. However, after approximately 30 single-stage regulators were tested, it was decided to remove these from the sample pool. Although single-stage regulators are still in service, they are no longer permitted for new installations per the 1995 Edition of NFPA 58. For this reason, it was decided to focus on test samples consisting only of first-stage, second-stage, or integral two-stage regulators. It is likely we would have received more single-stage regulators had we not focused on collection of regulators designed for two-stage systems.

It should be noted that Figures 37 through 39 do not show regulators that failed to perform during adjustment. These regulators are discussed further in Section 5.3.3. A general overview of single-stage regulator performance is provided in Table 6.

Table 10. Single-stage regulators that did not meet the UL 144 lock-up criteria for new regulators.

Regulator ID	Manuf.	Age	Climate	State	Service Area	Reason for Removal	Reason for Not Meeting UL Criteria
85	A	20	Cool, Dry	SD	Rural	Tank and regulator removed from service	High lock-up pressure; leak through PRD at high flowrates
92	A	16	Cool, Dry	SD	Rural	Tank and regulator removed from service	High lock-up pressure
97	A	11	Cool, Dry	SD	Rural		High lock-up pressure
98	A	18	Cool, Dry	SD	Rural	Tank and regulator removed from service	Missing bonnet cap; high lock-up pressure
150	A	13	Warm, Dry	MS	Rural	Changed from single to dual regulator system	High lock-up pressure
182	B	19	Warm, Damp	MS	Rural	Tank and regulator removed from service	Very rusty; high lock-up pressure
188	A	54	Warm, Damp	MS	Rural	Tank and regulator removed from service	Missing bonnet cap; high lock-up pressure
197	A	18	Warm, Dry	MS	Rural	End of manuf. recom. service life	High lock-up pressure; leaked through PRD
201	A	40	Warm, Dry	MS	Rural	End of manuf. recom. service life	Leak through regulator
226	A	11	Cool, Dry	SD	Rural	Tank and regulator removed from service	High lock-up pressure; missing vent screen
238	B	55	Cool, Dry	SD	Rural	Tank and regulator removed from service	Leak through regulator
313	A	16	Warm, Dry	MS	Rural	End of manuf. recom. service life	High lock-up pressure; high PRD start-to-discharge pressure
374	B	29	Cool, Dry	SD	Rural	Tank and regulator removed from service	High lock-up pressure
383	B	43	Cool, Dry	SD	Rural		High lock-up pressure; high PRD start-to-discharge pressure
397	A	23	Warm, Dry	AZ	Rural	Changed from single to dual regulator system	Outlet pressure would not stabilize
400	A	16	Warm, Dry	SC	Rural		Leak through PRD
407	A	12	Warm, Dry	SC	Rural	Tank and regulator removed from service	High lock-up pressure; high PRD start-to-discharge pressure

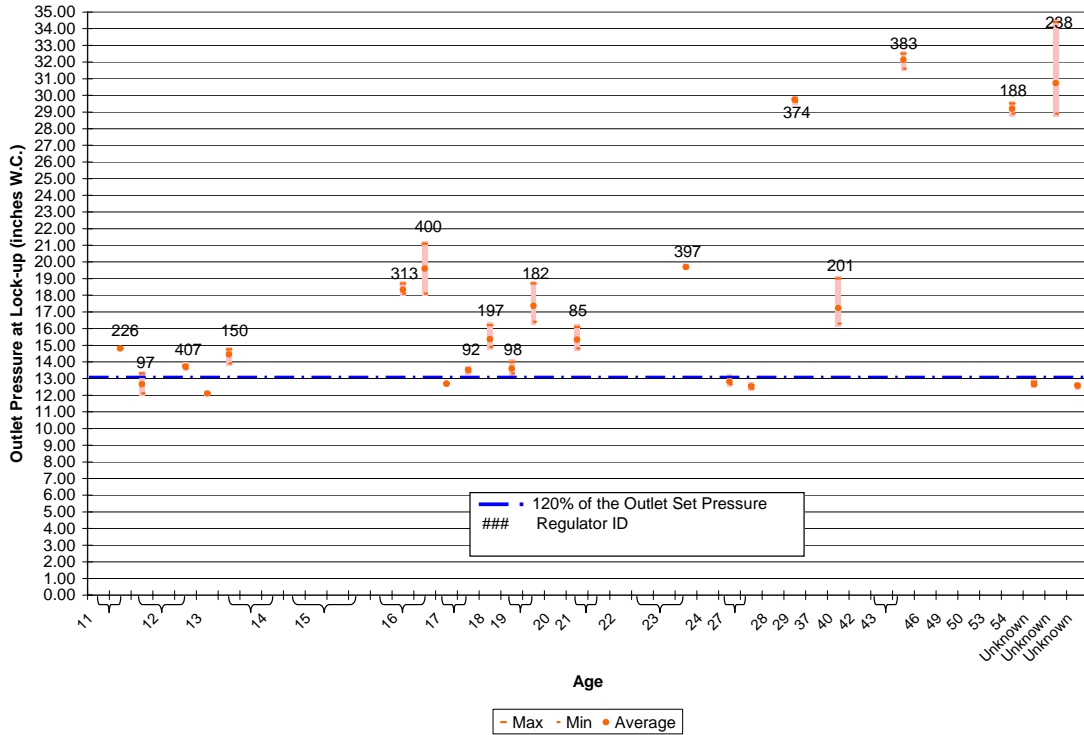

Figure 37. Lock-up pressures and age for single-stage regulators at 100 psig inlet pressure.

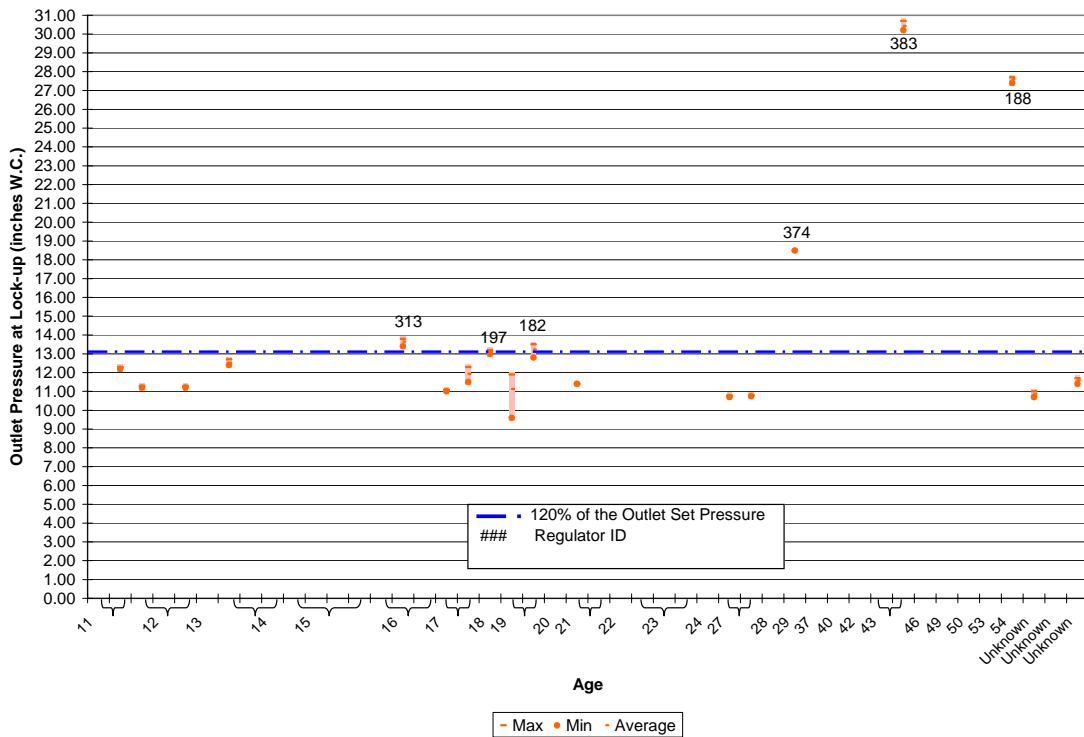

Figure 38. Lock-up pressures and age for single-stage regulators at 25 psig inlet pressure.

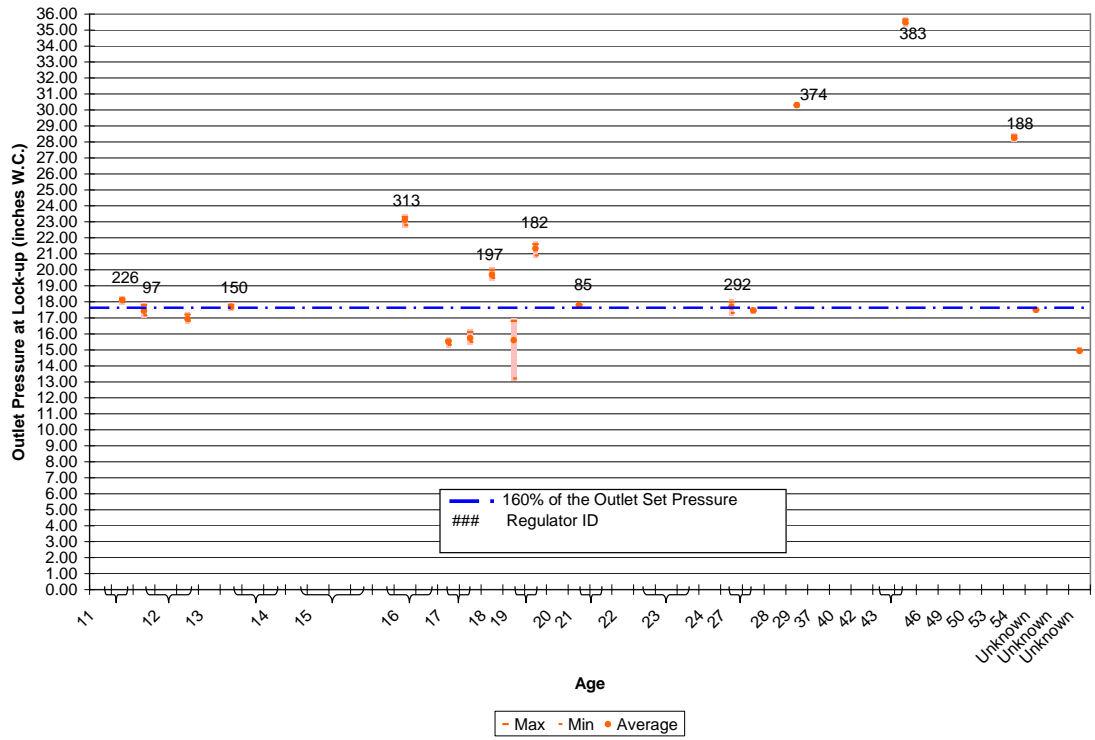

Figure 39. Lock-up pressures and age for single-stage regulators at 250 psig inlet pressure.

5.3.2 Summary of Pressure Relief Test Results

The pressure relief device start-to-discharge and reseal pressures of each regulator were measured and recorded in three successive trials for each test. In these tests, the start-to-discharge pressure was measured by slowly pressuring the regulator until the first indication of air escaping was observed using the flow meter. In many cases the relief device did not open fully until the pressure was increased further. Subsequently, the pressure in the regulator was reduced carefully until no air flow from the pressure relief device was observed. This was recorded as the reseal pressure. After the initial sequence, the start-to-discharge pressure and reseating pressure tests were repeated two more times. Figures 40 through 51 compare the start-to-discharge and reseal pressures to the test criteria and age for the regulators tested in this program.

First-Stage Regulators

Figures 40 through 45 compare the start-to-discharge and reseal pressures to the test criteria and age for the first-stage regulators tested in this program. The test results were fairly consistent with only five out of 50 first-stage regulators not meeting the pressure relief test criteria, all of which had start-to-discharge and/or reseating pressures that were too low. An additional 30 first-stage regulators did not have integral relief valves and therefore did not undergo these tests.

All regulators that did not meet the PRD test criteria were from Manufacturer B. Four out of the five regulators were under 15 years of age, one of which was listed as a faulty regulator by the

marketer. Additionally, these regulators were either from a cool, dry or warm, dry environment. This data does not reflect regulator pressure relief performance for regulators older than 25 years of age since many of these regulators were not equipped with integral relief devices. Details for the first-stage regulators that did not meet the PRD test criteria are provided in Table 11.

It should be noted that Figures 40 through 45 do not show regulators that failed to perform during adjustment. These regulators are discussed further in Section 5.3.5. A general overview of first-stage regulator performance is provided in Table 3.

Table 11. First-stage regulators that did not meet the UL 144 PRD criteria for new regulators.

Regulator ID	Manuf.	Age	Climate	State	Service Area	Reason for Removal	Reason for Not Meeting UL Criteria
247	B	8	Cool, Dry	SD	Rural	Tank and regulator removed from service	PRD reseating pressure too low
361	B	27	Warm, Dry	CA	Urban	Tank and regulator removed from service	PRD start-to-discharge and reseating pressures too low; dirty exterior; clean interior; could not adjust
440	B	6	Warm, Dry	SC	Rural	Other	PRD reseating pressure too low; no adjustment
617	B	10	Cool, Dry	IA	Rural	Faulty regulator: Leaked	PRD start-to-discharge and reseating pressures too low
656	B	4	Cool, Dry	NY	Urban	Other: Relocated tank; changed regs.	PRD start-to-discharge and reseating pressures too low

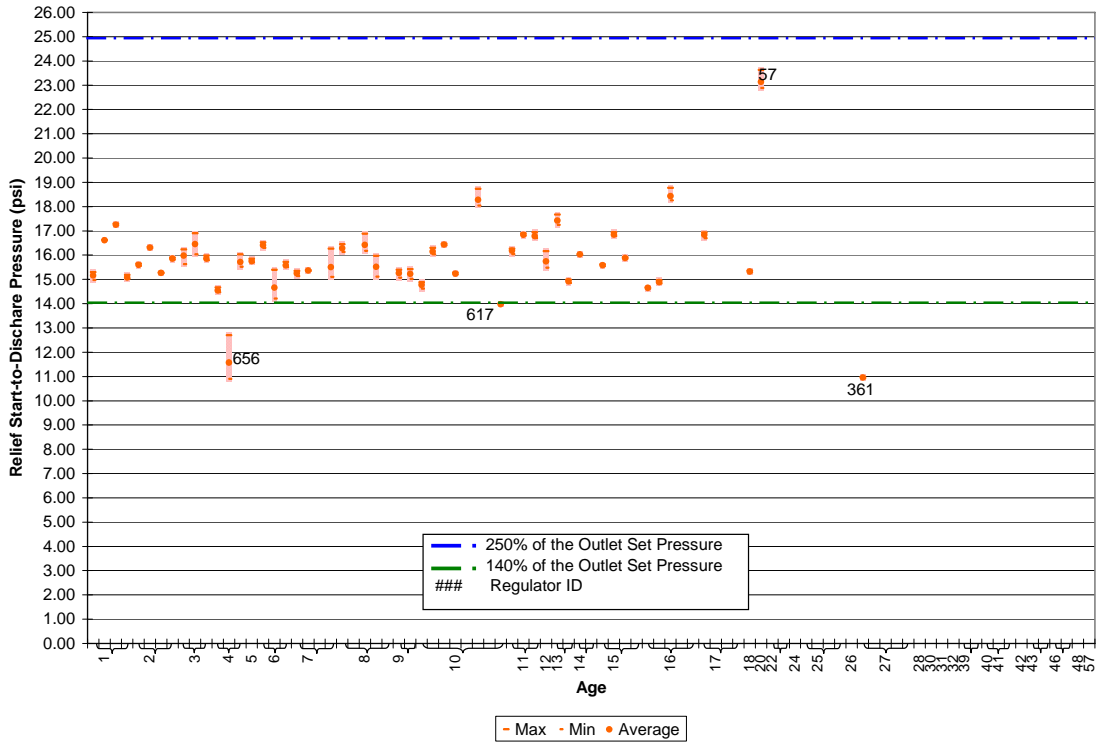

Figure 40. Start-to-discharge pressures and age for 10 psi first-stage regulators.

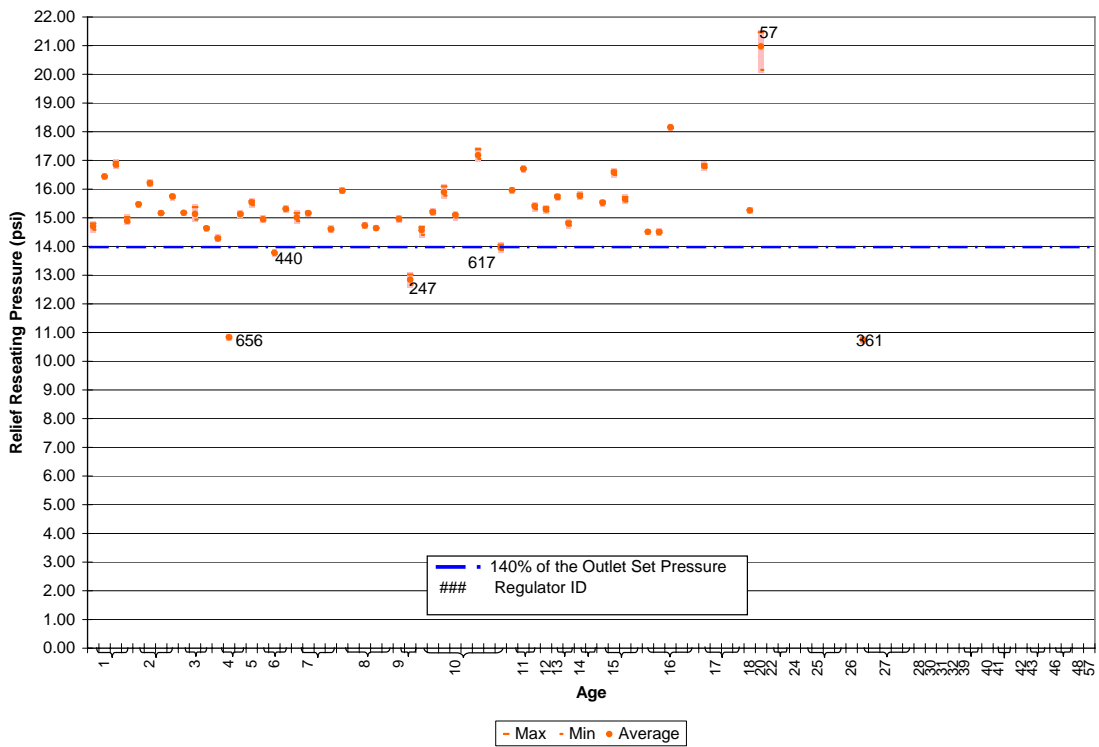

Figure 41. Reseat pressures and age for 10 psi first-stage regulators.

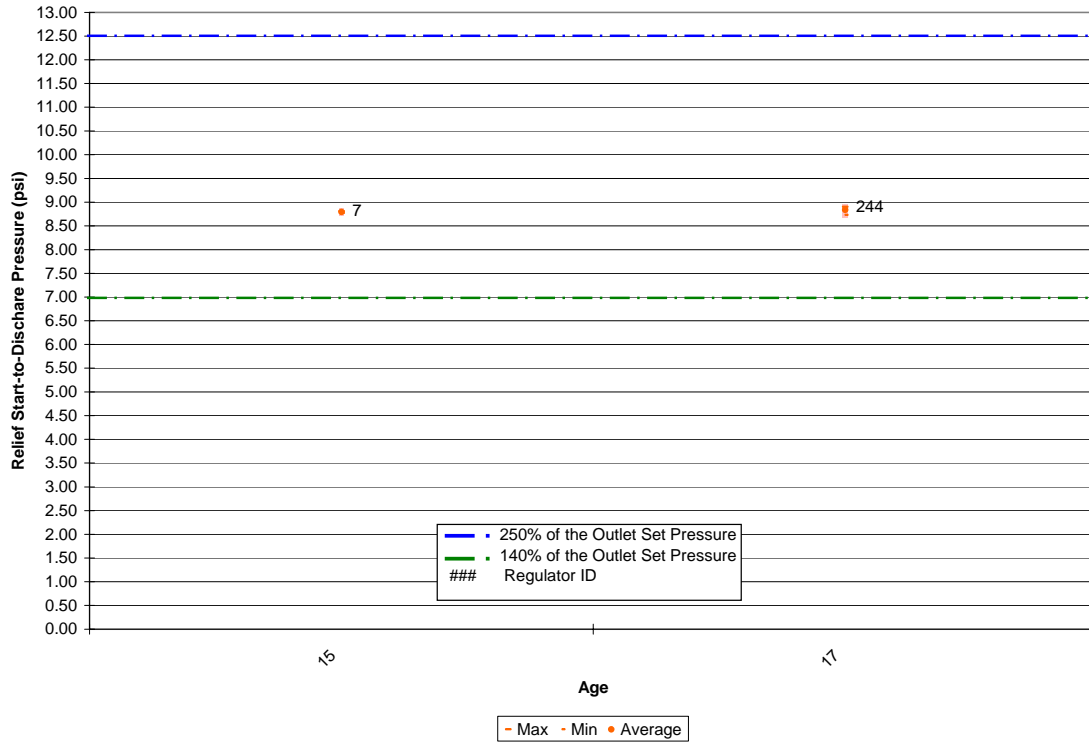

Figure 42. Start-to-discharge pressures and age for 5 psi first-stage regulators.

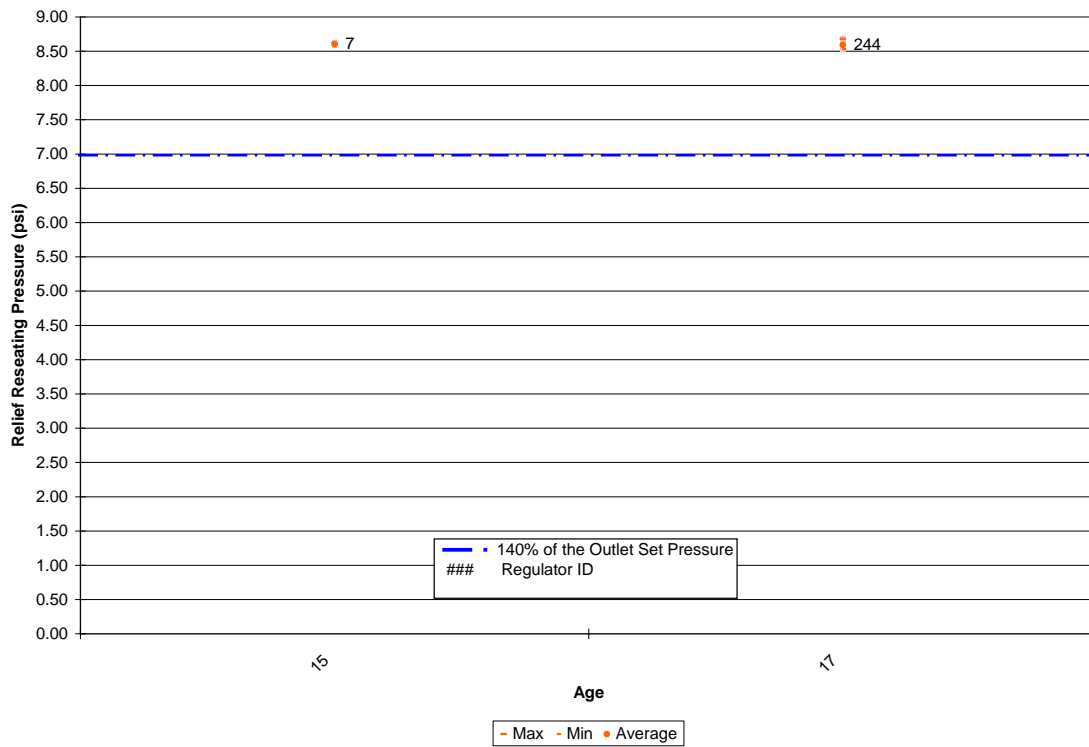

Figure 43. Reseat pressures and age for 5 psi first-stage regulators.

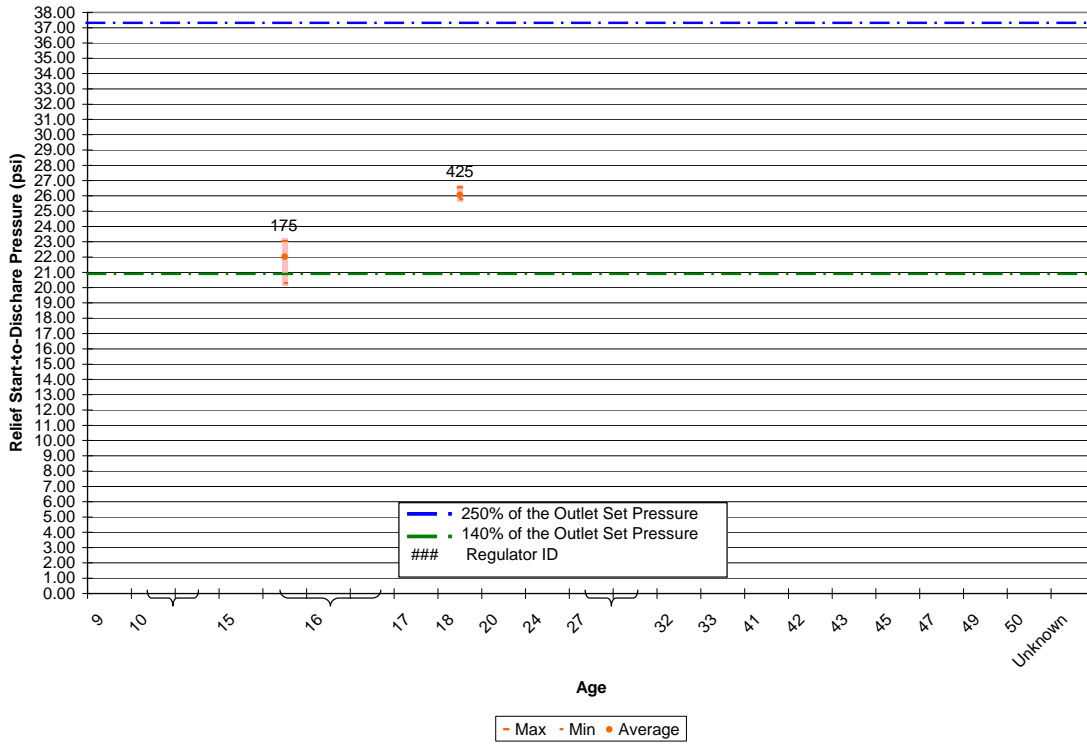

Figure 44. Start-to-discharge pressures and age for 15 psi first-stage regulators.

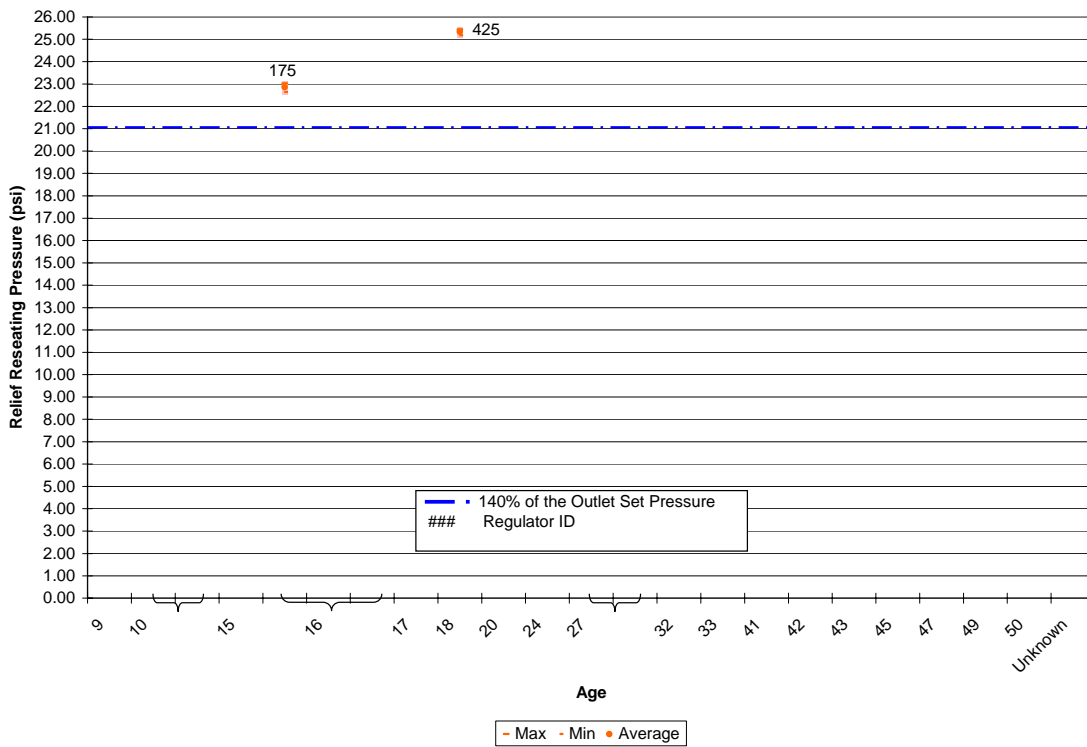

Figure 45. Reseat pressures and age for 15 psi first-stage regulators.

Second-Stage Regulators

Figures 46 through 47 compare the start-to-discharge and reseal pressures to the test criteria and age for the second-stage regulators tested in this program. The test results were widely scattered for resealing pressures regardless of regulator age. However, there does appear to be a slight age affect for the start-to-discharge pressures. More regulators older than 15 years tended to exceed the PRD test criteria than regulators less than 15 years in age. Of the 78 second-stage regulators that underwent the pressure relief tests 27 regulators did not meet the test criteria. Most of these regulators had start-to-discharge pressures that were too high ranging from 33.2 inches of water to 60.1 inches of water. One regulator still did not relieve after reaching 65 inches of water.

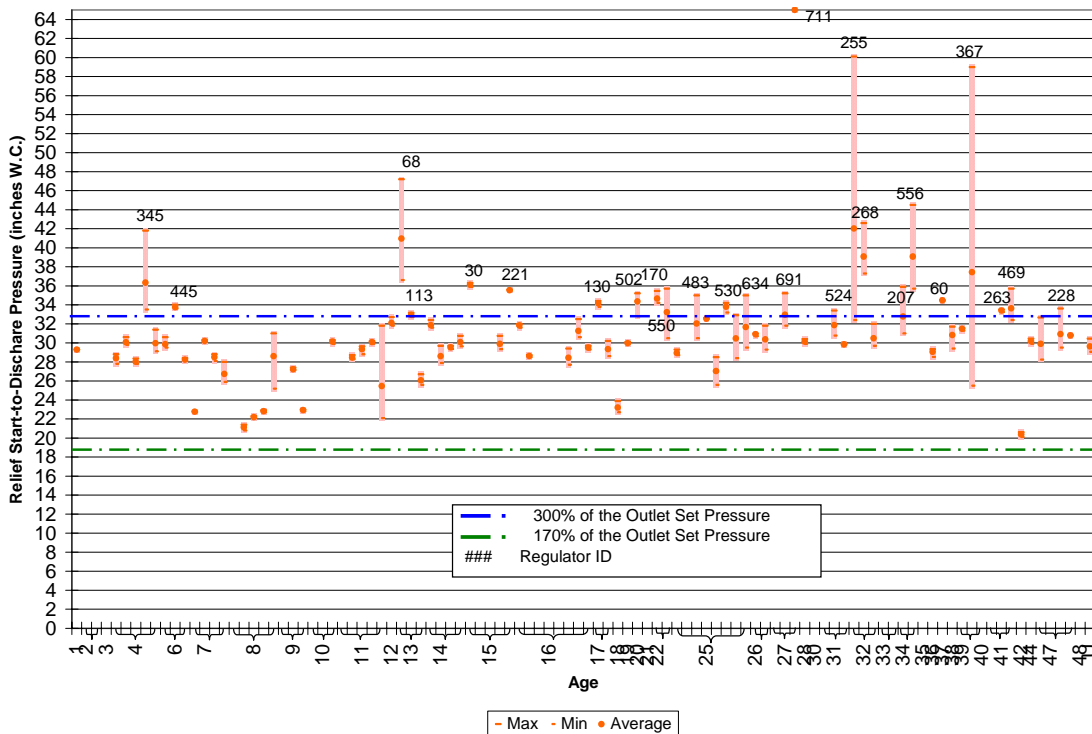

Figure 46. Start-to-discharge pressures and age for second-stage regulators.

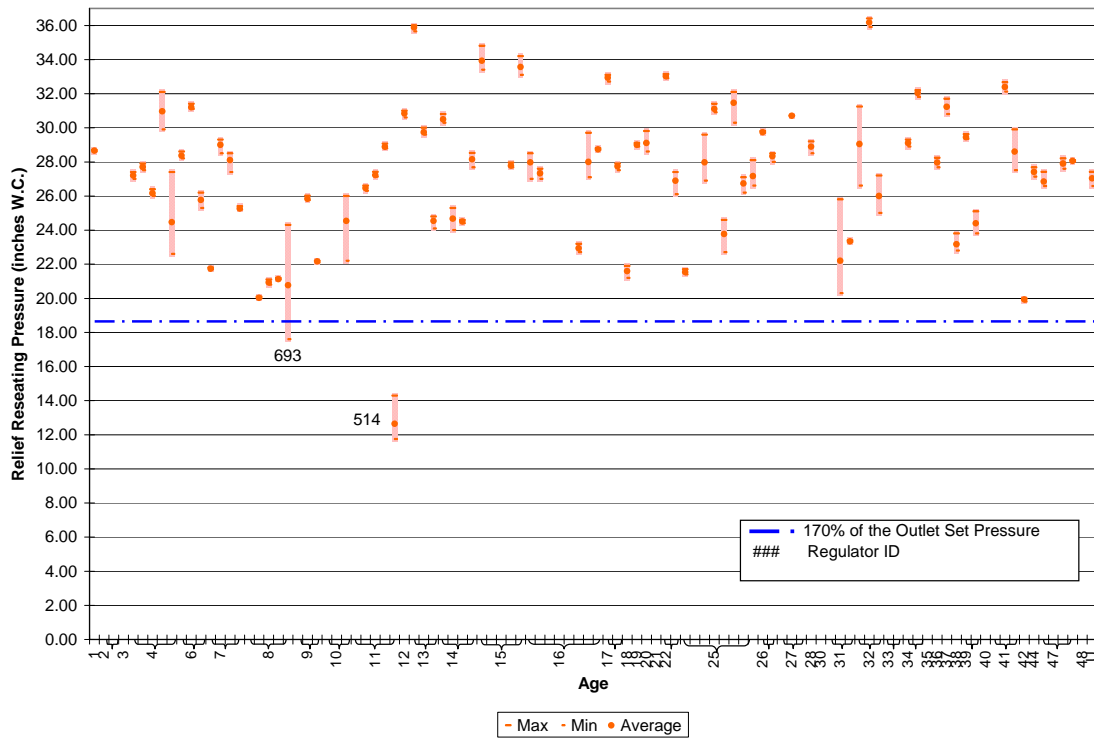

Figure 47. Reseat pressures and age for second-stage regulators.

There does not appear to be a correlation between second-stage regulator relief performance and different environments and/or manufacturers. Details for the second-stage regulators that did not meet the PRD test criteria are provided in Table 12.

It should be noted that Figures 46 through 47 do not show regulators that failed to perform during adjustment. These regulators are discussed further in Section 5.3.5. A general overview of second-stage regulator performance is provided in Table 4.

Table 12. Second-stage regulators that did not meet the UL 144 PRD criteria for new regulators.

Reg. ID	Manuf.	Age	Climate	State	Service Area	Reason for Removal	Reason for Not Meeting UL Criteria
30	B	15	Cool, Dry	IA	Rural	End of manuf. rec.om. service life	PRD start-to-discharge pressure too high
60	A	37	Warm, Dry	MS	Rural	Tank and regulator removed from service	PRD start-to-discharge pressure too high
68	B	13	Cool, Damp	OH	Suburban	Tank and regulator removed from service	PRD start-to-discharge pressure too high
113	A	13	Cool, Dry	NH	Rural	Other	PRD start-to-discharge pressure too high for first trial
130	B	17	Warm, Damp	NC	Suburban	End of manuf. recom. service life	PRD start-to-discharge pressure too high; fittings rusty, difficult to remove
170	A	22	Warm, Dry	KY	Suburban	End of manuf. recom. service life	PRD start-to-discharge pressure too high; fittings rusty, difficult to remove
207	A	34	Cool, Damp	ME	Rural	Tank and regulator removed from service	PRD start-to-discharge pressure too high for first trial
221	A	15	Cool, Damp	MI	Rural	End of manuf. recom. service life	PRD start-to-discharge pressure too high; fittings rusty, difficult to remove
228	B	47	Cool, Dry	SD	Rural	Tank and regulator removed from service	PRD start-to-discharge pressure too high for first trial; high lock-up pressure
255	B	32	Cool, Dry	IA	Rural	End of manuf. recom. service life	PRD start-to-discharge pressure too high
263	A	41	Cool, Dry	IA	Rural	End of manuf. recom. service life	PRD start-to-discharge pressure too high
268	A	32	Cool, Dry	IA	Rural	End of manuf. recom. service life	PRD start-to-discharge pressure too high; bolts in regulator are rusty
345	A	4	Warm, Dry	KY	Rural	Other	PRD start-to-discharge pressure too high for first trial; high lock-up
367	B	39	Warm, Damp	WA	Urban	Tank and regulator removed from service	PRD start-to-discharge pressure too high
445	B	6	Warm, Dry	SC	Rural	Tank and regulator removed from service	PRD start-to-discharge pressure too high
469	A	41	Cool, Dry	WI	Urban	End of manuf. recom. service life	PRD start-to-discharge pressure too high for first trial
483	A	25	Cool, Damp	IN	Rural	End of manuf. recom. service life	PRD start-to-discharge pressure too high for first trial
502	B	20	Cool, Dry	IA	Rural	End of manuf. recom. service life	PRD start-to-discharge pressure too high
514	A	11	Warm, Damp	VA	Rural	Tank and regulator removed from service	PRD reseating pressure too low
524	B	31	Cool, Damp	PA	Suburban	End of manuf. recom. service life	PRD start-to-discharge pressure too high for first trial
530	B	25	Cool, Damp	PA	Suburban	End of manuf. recom. service life	PRD start-to-discharge pressure too high
550	B	22	Cool, Damp	IN	Rural	End of manuf. recom. service life	Very rusty; PRD start-to-discharge pressure too high
556	A	34	Cool, Damp	IN	Rural	End of manuf. recom. service life	PRD start-to-discharge pressure too high
634	A	25	Warm, Dry	NJ	Suburban	End of manuf. recom. service life	PRD start-to-discharge pressure too high for first trial
691	B	27	Cool, Dry	SD	Urban	End of manuf. recom. service life	PRD start-to-discharge pressure too high for first trial
693	B	8	Cool, Dry	SD	Rural	Tank and regulator removed from service	PRD reseating pressure too low
711	A	27	Cool, Dry	SD	Rural	End of manuf. recom. service life	PRD did not relieve after reaching 65" W.C.

Integral Two-Stage Regulators

Figures 48 through 49 compare the start-to-discharge and reseal pressures to the test criteria and age for the integral two-stage regulators tested in this program. The test results were widely scattered regardless of regulator age. Of the 11 integral two-stage regulators that underwent the pressure relief tests four regulators did not meet the test criteria. Most of these regulators had start-to-discharge pressures that were too high ranging from 33.7 inches of water to 36.7 inches of water and ranged in age from 1 to 28 years. Additionally, two of the regulators that did not meet the test criteria were listed as “faulty regulators” by the marketer.

All regulators that did not meet the pressure relief test criteria were from Manufacturer B and came from two specific locations. Such a small sample size makes it difficult to determine any trends between age, environmental conditions, and manufacturers and regulator performance. Details for the integral two-stage regulators that did not meet the PRD test criteria are provided in Table 13.

It should be noted that Figures 48 through 49 do not show regulators that failed to perform during adjustment. These regulators are discussed further in Section 5.3.5. A general overview of integral two-stage regulator performance is provided in Table 5.

Table 13. Integral two-stage regulators that did not meet the UL 144 PRD criteria for new regulators.

Regulator ID	Manuf.	Age	Climate	State	Service Area	Reason for Removal	Reason for Not Meeting UL Criteria
106	B	11	Cool, Damp	AK	Rural	Faulty Regulator	PRD start-to-discharge pressure too high
348	B	1	Cool, Damp	AK	Rural	Other	PRD start-to-discharge pressure too high
477	B	9	Warm, Dry	NJ	Suburban	Tank and regulator removed from service	PRD reseating pressure too low
637	B	28	Warm, Dry	NJ	Rural	Faulty Regulator: Leaks	PRD start-to-discharge pressure too high

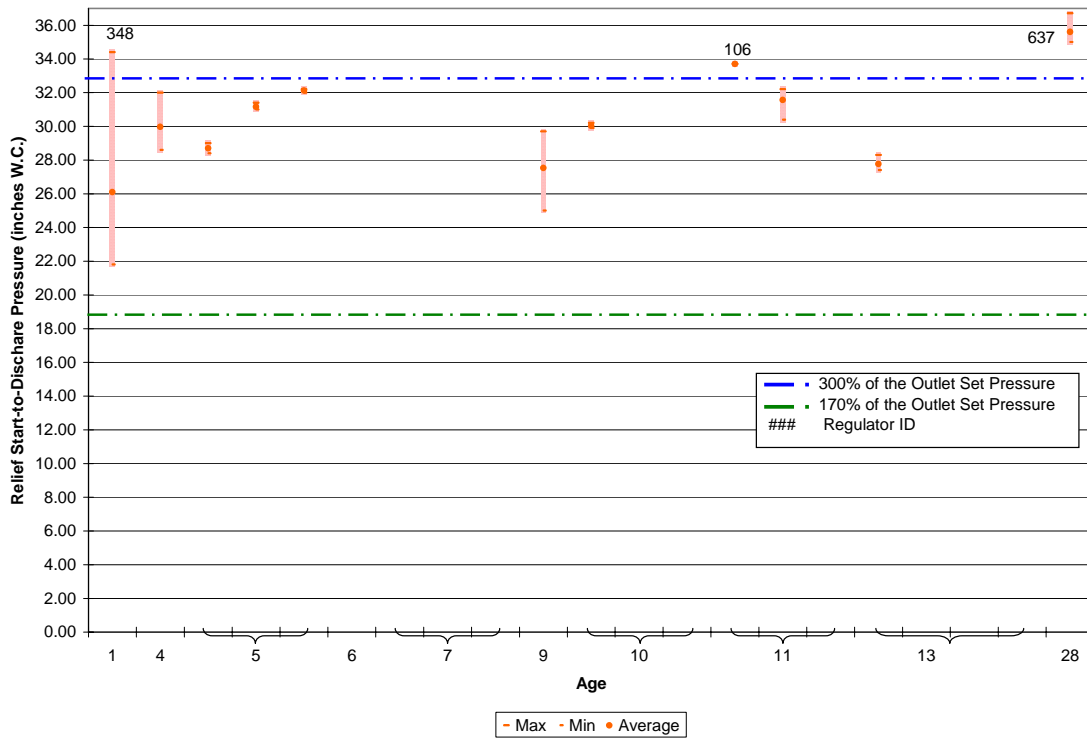

Figure 48. Start-to-discharge pressures and age for integral two-stage regulators.

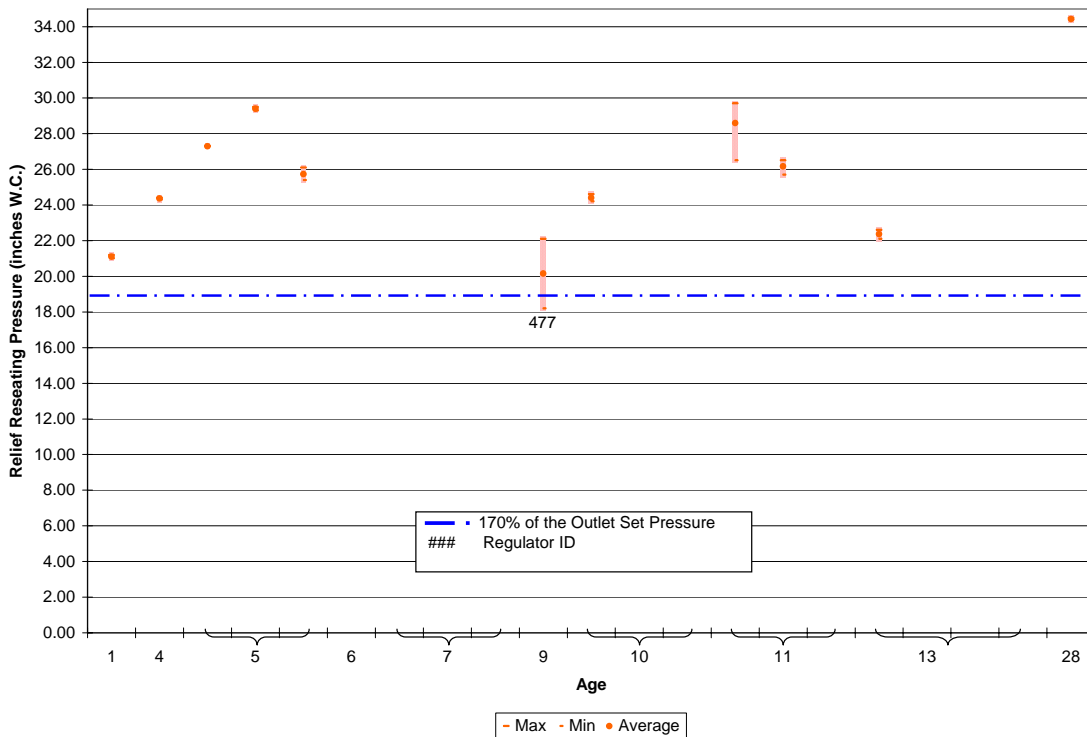

Figure 49. Reseat pressures and age for integral two-stage regulators.

Single-Stage Regulators

Figures 50 through 51 compare the start-to-discharge and reseal pressures to the test criteria and age for the single-stage regulators tested in this program. The test results were widely scattered regardless of regulator age. Of the 17 single-stage regulators that underwent the pressure relief tests nearly half of the regulators (8) did not meet the test criteria. Most of these regulators had start-to-discharge pressures that were too high ranging from 33.5 inches of water to 43 inches of water and ranged in age from 12 to 43 years.

Most regulators that did not meet the pressure relief test criteria were from Manufacturer A however more than two-thirds of the single-stage regulators received were from Manufacturer A. Most of the regulators that did not meet the test criteria were from a cool, dry or a warm, dry environment. Details for the single-stage regulators that did not meet the PRD test criteria are provided in Table 14.

It should be noted that Figures 50 through 51 do not show regulators that failed to perform during adjustment. These regulators are discussed further in Section 5.3.5. A general overview of single-stage regulator performance is provided in Table 6.

Table 14. Single-stage regulators that did not meet the UL 144 PRD criteria for new regulators.

Regulator ID	Manuf.	Age	Climate	State	Service Area	Reason for Removal	Reason for Not Meeting UL Criteria
67	A	27	Cool, Damp	OH	Rural	Tank and regulator removed from service	PRD start-to-discharge pressure too high
91	A	16	Cool, Dry	SD	Rural	Tank and regulator removed from service	Stiff adjusting spring; PRD start-to-discharge pressure too high
197	A	18	Warm, Dry	MS	Rural	End of manuf. recom. service life	High lock-up; Leak through PRD; PRD start-to-discharge pressure too high
231	A	22	Cool, Dry	SD	Rural	Tank and regulator removed from service	PRD start-to-discharge pressure too high in first trial
292	A	27	Cool, Dry	SD	Rural	Tank and regulator removed from service	PRD start-to-discharge pressure too high; high lock-up; PRD screen missing
313	A	16	Warm, Dry	MS	Rural	End of manuf. recom. service life	PRD start-to-discharge pressure too high; high lock-up
383	B	43	Cool, Dry	SD	Rural		PRD start-to-discharge pressure too high in first trial; high lock-up
407	A	12	Warm, Dry	SC	Urban	Tank and regulator removed from service	PRD start-to-discharge pressure too high; high lock-up

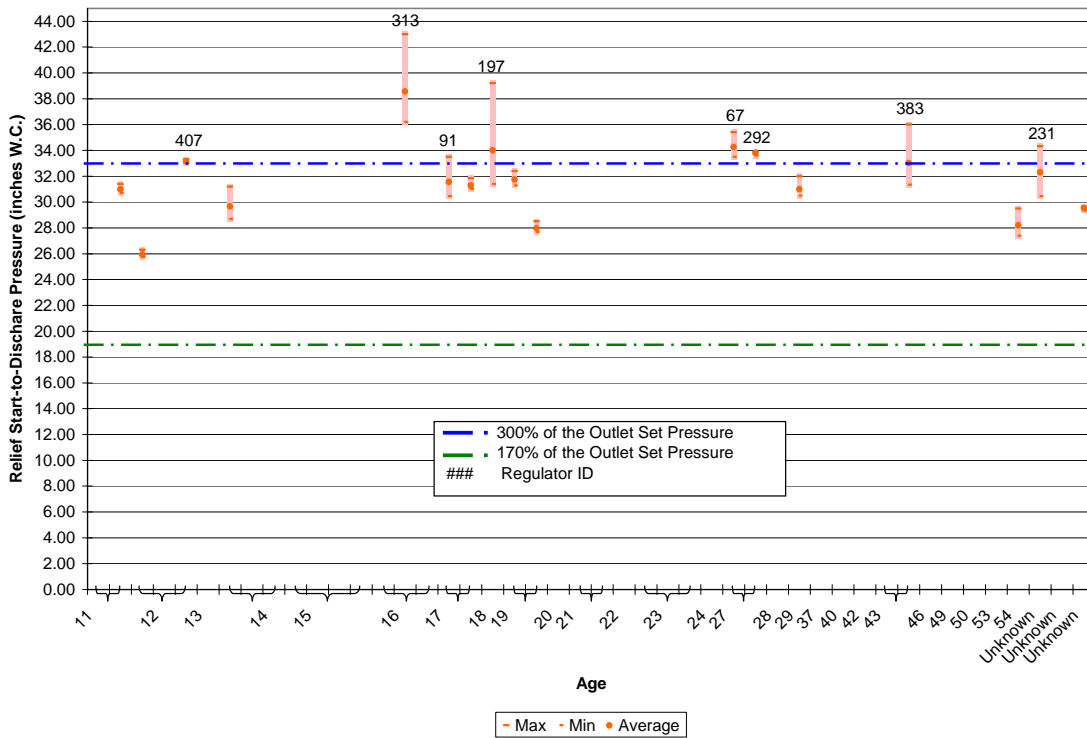

Figure 50. Start-to-discharge pressures and age for single-stage regulators.

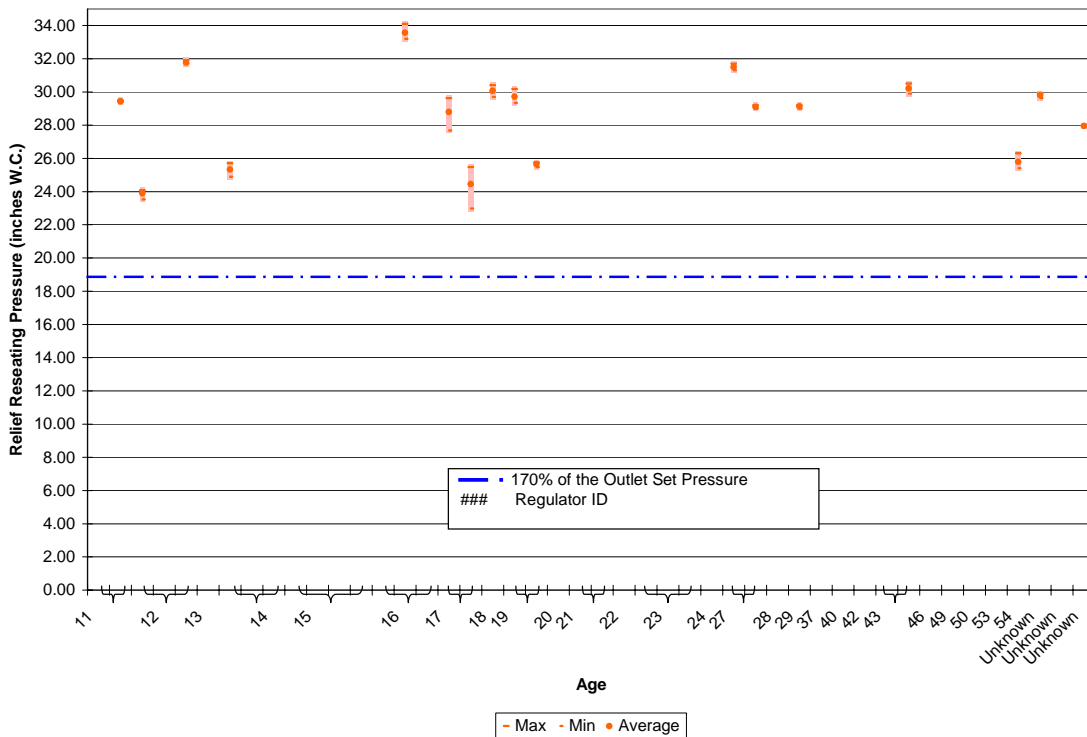

Figure 51. Reseat pressures and age for single-stage regulators.

5.3.3 Effects of Manufacturer on Regulator Performance

As previously mentioned, the numbers of regulators tested were fairly evenly distributed between two manufacturers, “A” and “B”, with over 125 of each manufacturer’s units tested. Figures 52 through 54 show the lockup pressures, relief start-to-discharge pressures, and relief reseal pressures for first-stage regulators, sorted by manufacturer. As the other previously discussed charts, the vertical axis is the parameter tested (lockup, etc.). The horizontal axis is an indication of the number of regulators tested. If there were significant differences between the manufacturers, there would be a noticeable variation of the vertical spread of the data points taken as a group (considering all regulators tested of one manufacturer). Another difference would be the variability of a particular regulator, displayed as vertically stacked points. On these charts, if one manufacturer’s units were more or less repeatable, it would be noticeable on these charts. These figures show neither of these variabilities, indicating that there is no significant difference in the data between the manufacturers. Similarly, Figures 55 through 56 show the lockup pressures, relief start-to-discharge pressure, and relief reseal pressure for second-stage regulators, sorted by brand, and Figures 58 through 60 show the lockup pressures, relief start-to-discharge pressure, and relief reseal pressure for single-stage regulators, sorted by brand. For these second-stage and single-stage regulators, there is also no significant difference in the data between the manufacturers.

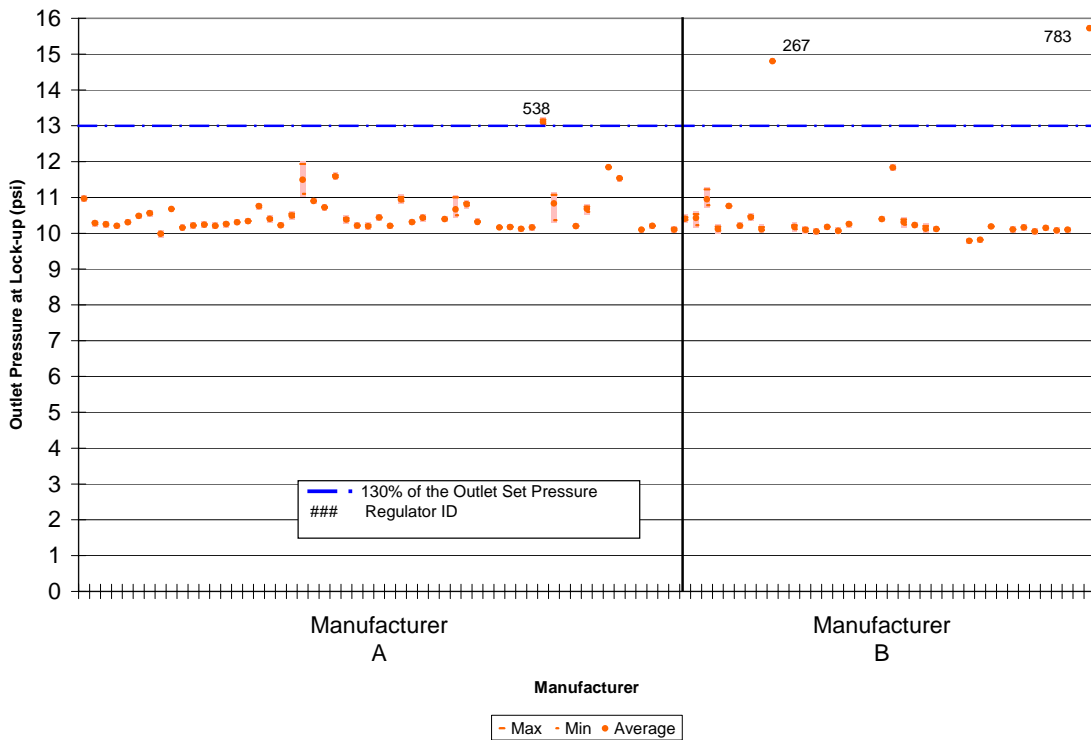

Figure 52. Lock-up pressures and manufacturer for 10 psi first-stage regulators at 100 psig inlet pressure.

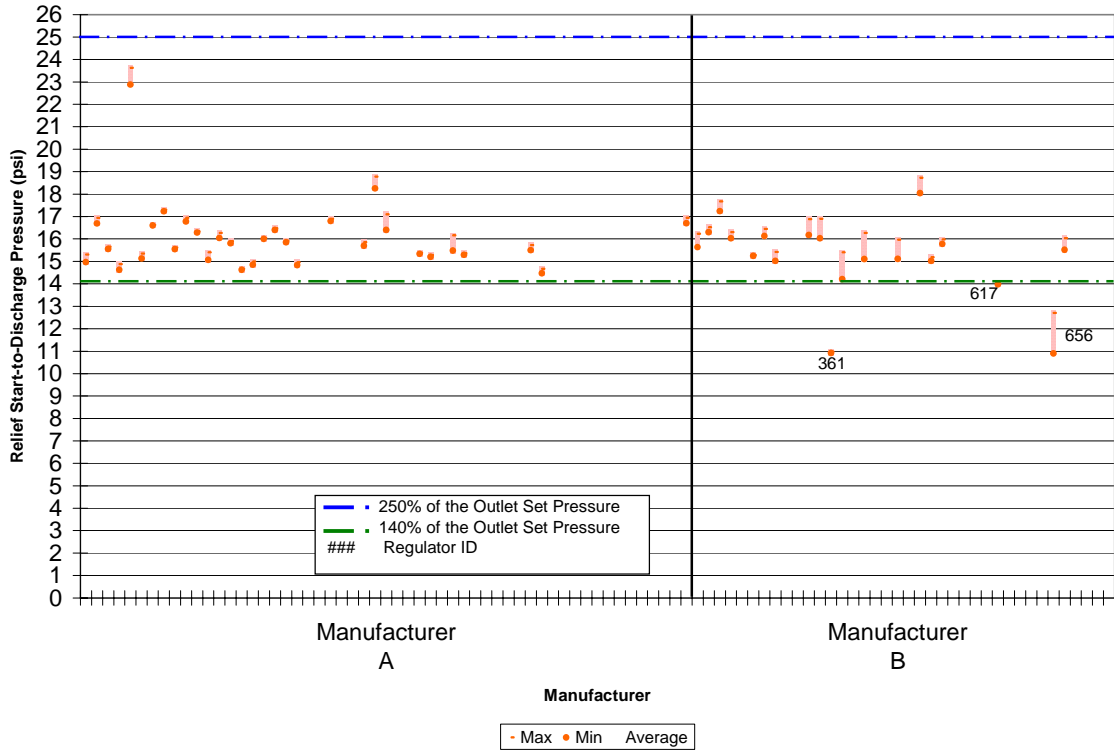

Figure 53. Start-to-discharge pressures and manufacturer for 10 psi first-stage regulators.

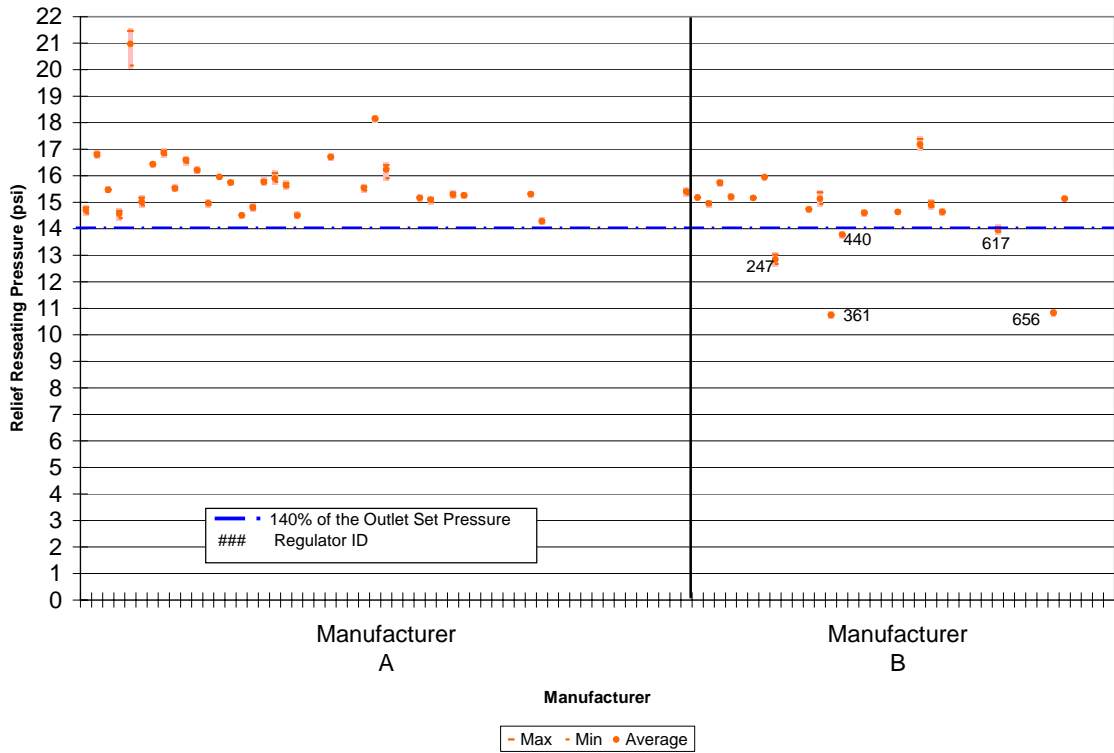

Figure 54. Reseat pressures and manufacturer for 10 psi first-stage regulators.

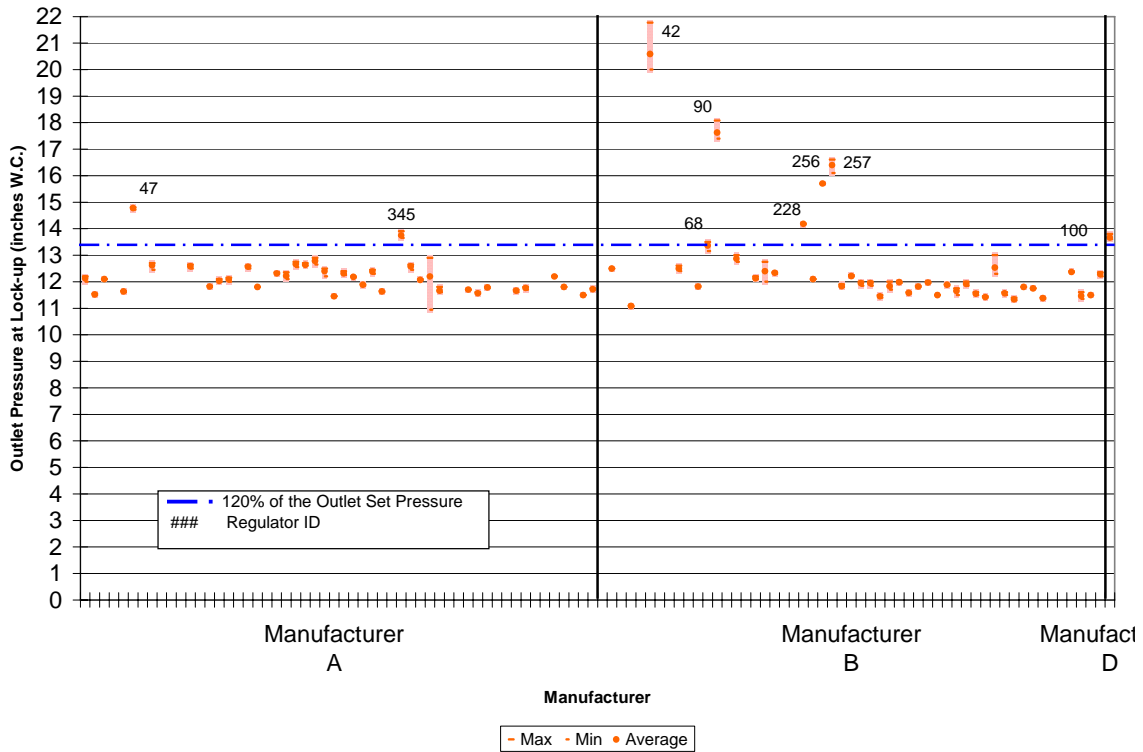

Figure 55. Lock-up pressures and manufacturer for second-stage regulators at 10 psig inlet pressure.

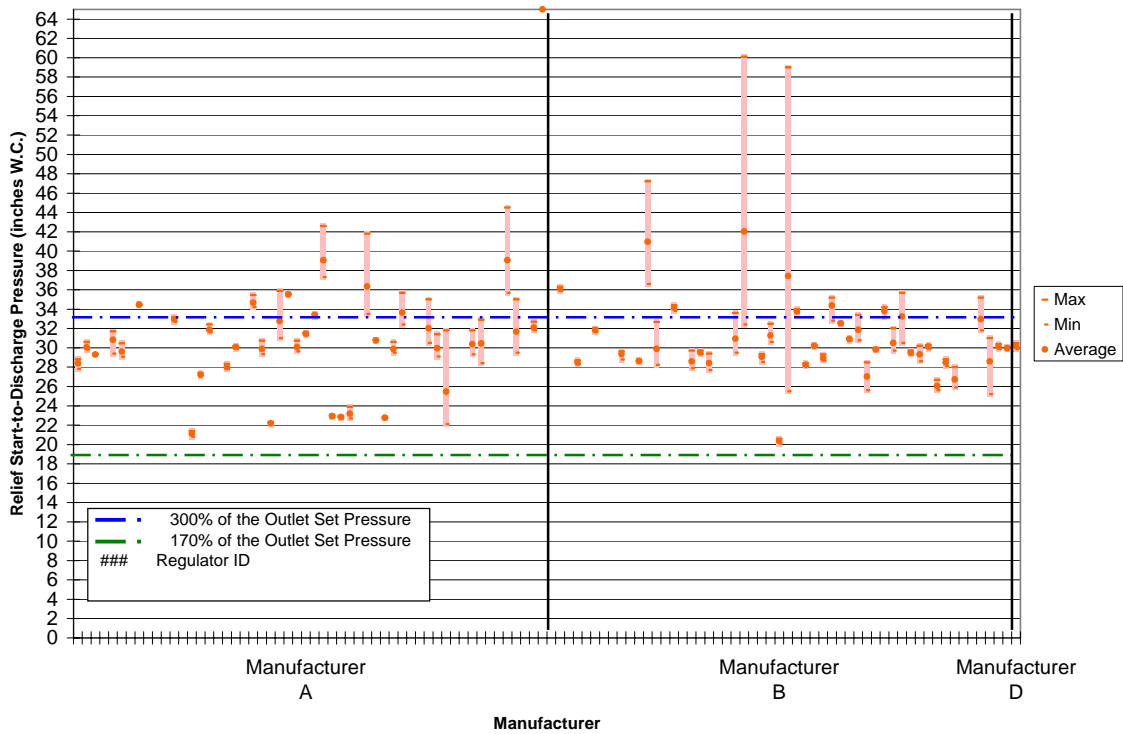

Figure 56. Start-to-discharge pressures and manufacturer for second-stage regulators.

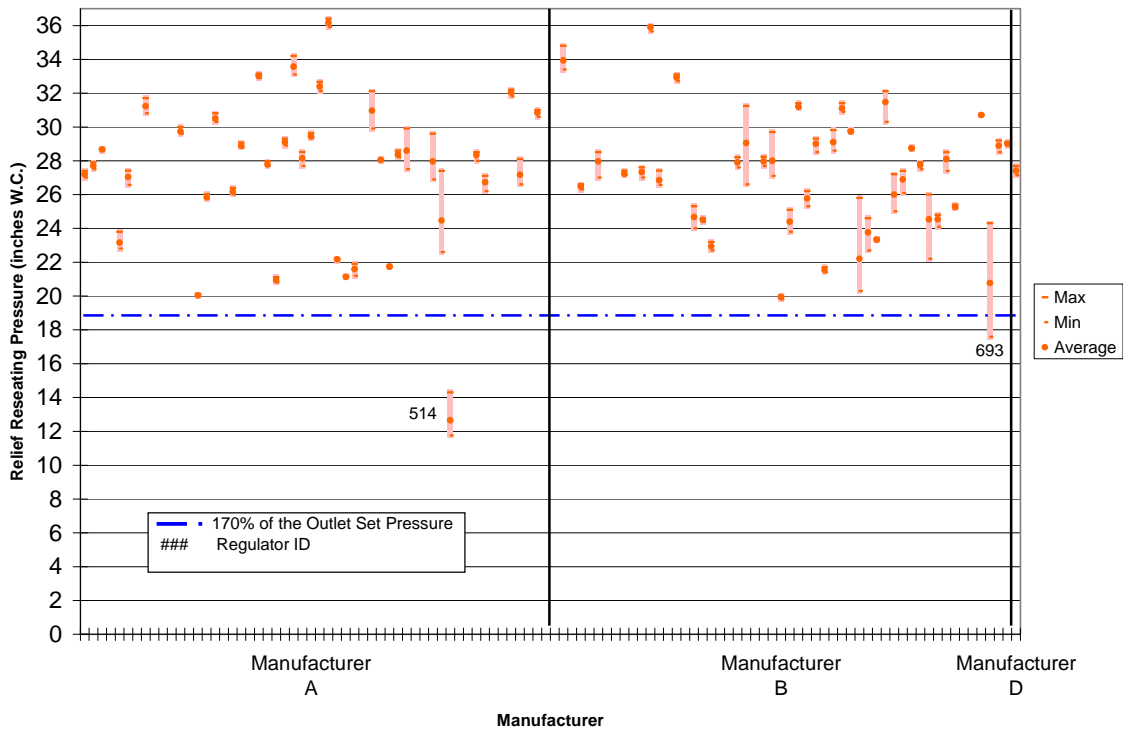

Figure 57. Reseat pressures and manufacturer for second-stage regulators.

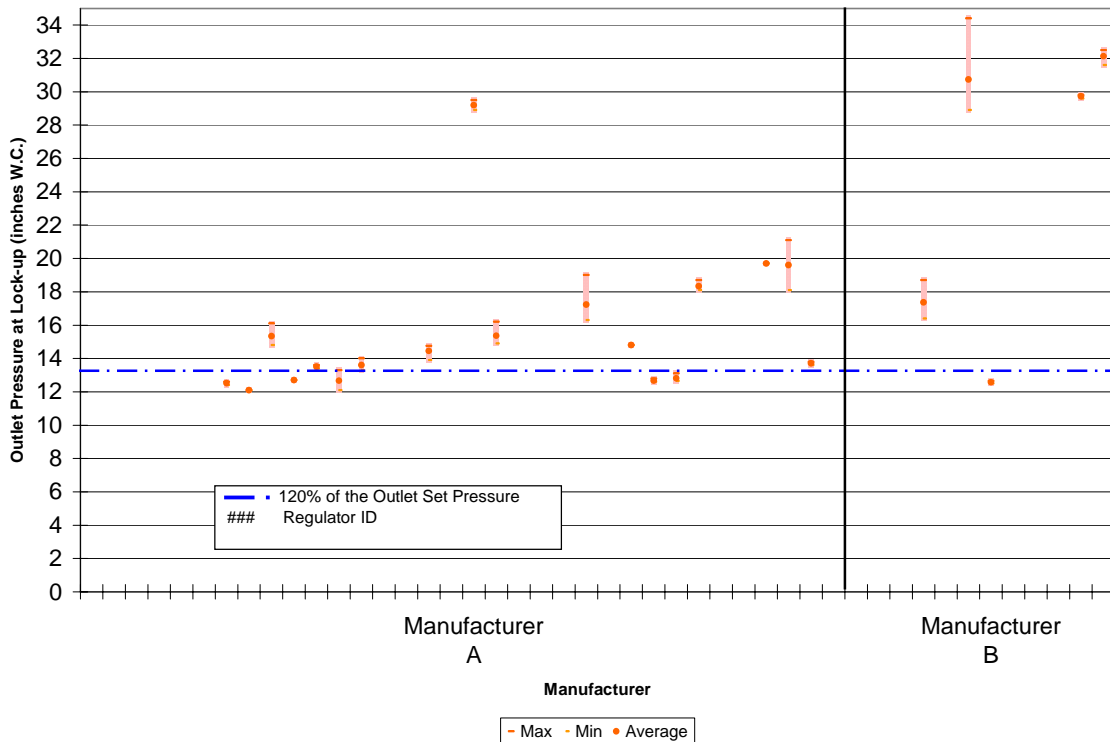

Figure 58. Lock-up pressures and manufacturer for single-stage regulators at 100 psig inlet pressure.

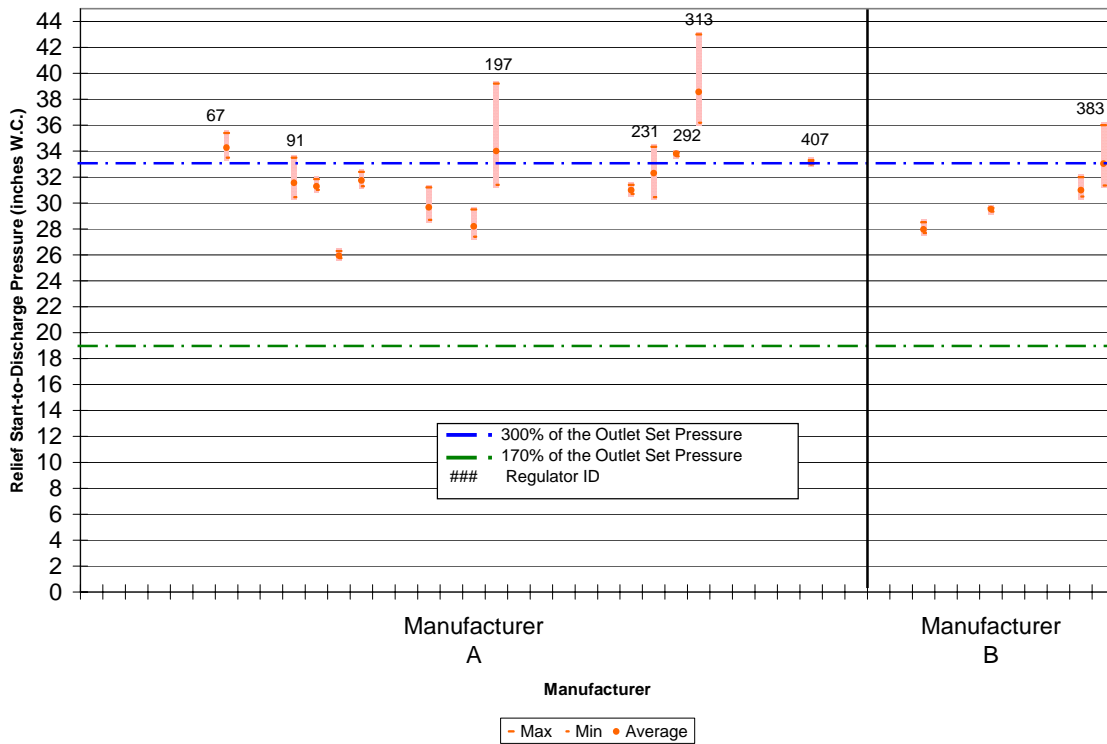

Figure 59. Start-to-discharge pressures and manufacturer for single-stage regulators.

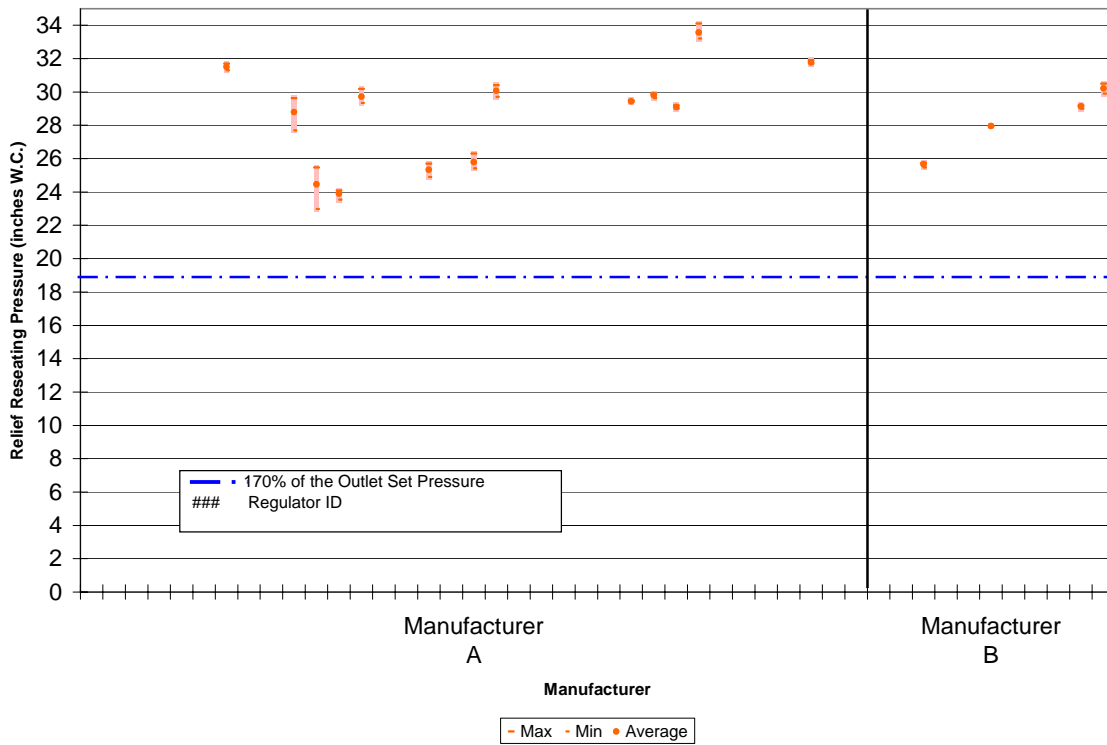

Figure 60. Reseat pressures and age for single-stage regulators.

Figure 61 shows a summary of the failed regulators. More regulators from Manufacturer A and B were tested than the other manufacturers as shown by Figure 11. Roughly 53 percent of the regulators tested were from Manufacturer A and approximately 47 percent were from Manufacturer B. Each of these showed similar range of results for lock-up, start-to-discharge, and reseal pressures. While the overall range was similar, more of the Manufacturer A regulators met the test criteria.

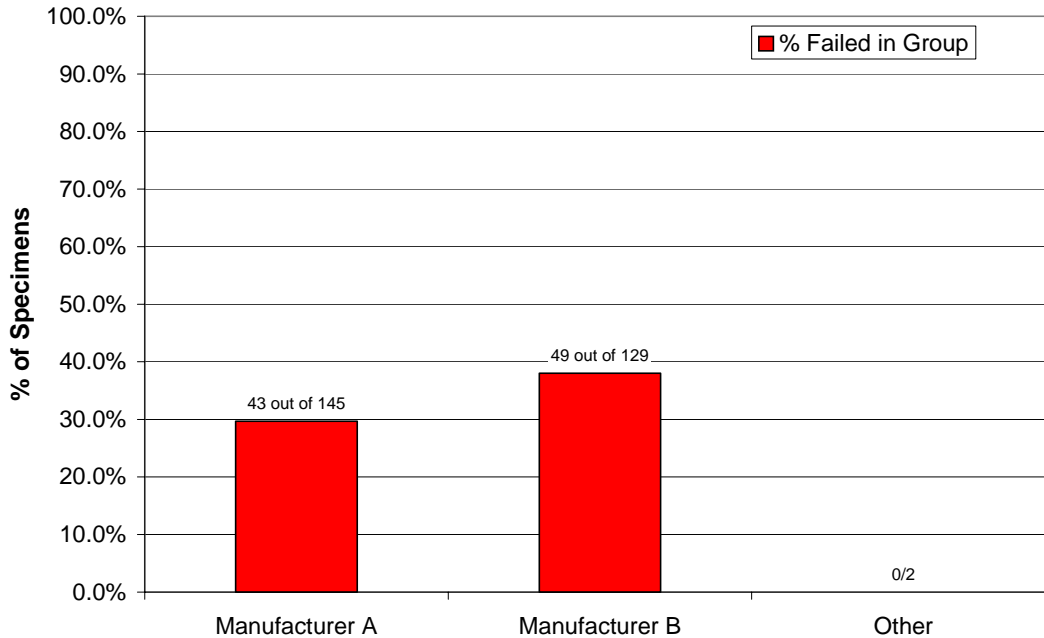

Figure 61. Regulator failures by regulator manufacturer.

5.3.4 Effects of Environment on Regulator Performance

The test data were replotted from the perspective of the four environmental regions, as shown in Figures 6 and 8:

- Warm; dry ($\geq 53^{\circ}\text{F}$; $< 73\%$ humidity),
- Warm; damp ($\geq 53^{\circ}\text{F}$; $\geq 73\%$ humidity),
- Cool; dry ($< 53^{\circ}\text{F}$; $< 73\%$ humidity), and
- Cool; damp ($< 53^{\circ}\text{F}$; $\geq 73\%$ humidity).

The source environment comparison in Figures 62 through 70 shows fairly consistent behavior in pressure tests of lock-up, PRD start-to-discharge, and PRD reseal across each environment. Each environment shows similar scatter and range for these tests. Any of the apparent differences in scatter that the data might suggest are more likely to be the result of differences in the number of specimens from each environment. These plots do not suggest major differences in pressure test

performance that are a result of source environment. However, Figure 71, which shows the number of failed regulators for the four environmental conditions, shows a higher percentage of failures from a warm, dry environment. With the number of samples being reasonably significant (much greater than ten units), the fact that nearly half of the warm, dry regulators failed to meet the test criteria is also significant. While internal and external corrosion may be considered a significant failure mechanism, perhaps the drying effects on elastomeric components such as seals and the diaphragm may be more significant.

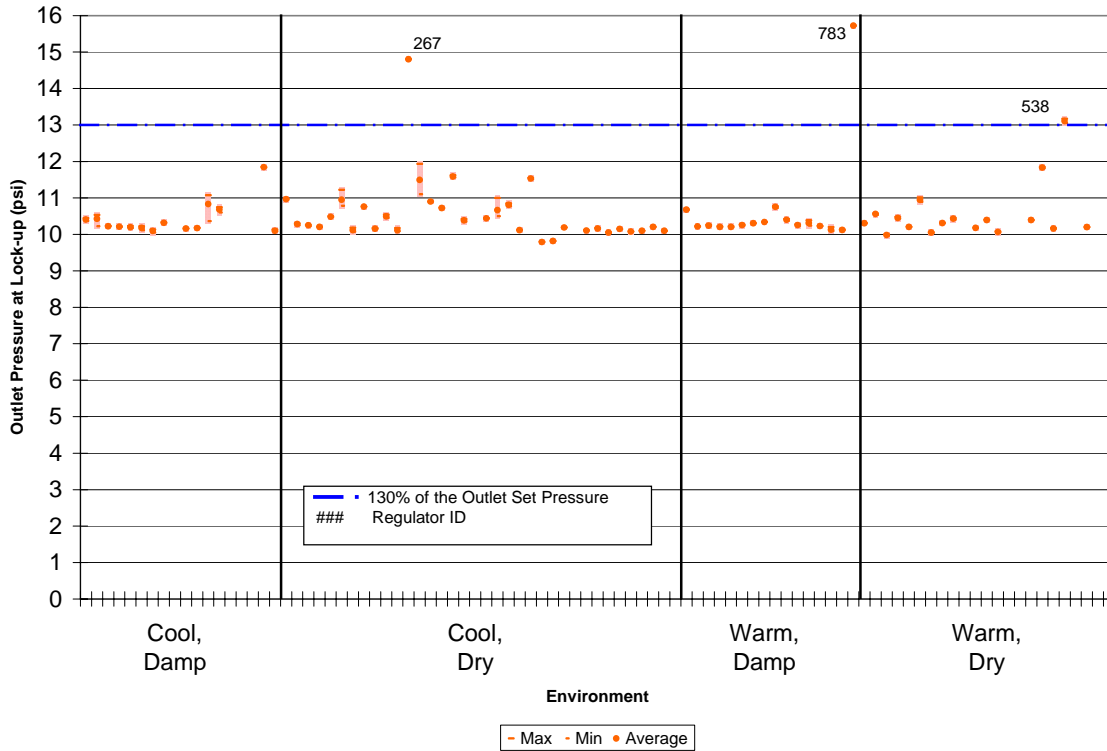

Figure 62. Lock-up pressures and environment for 10 psi first-stage regulators at 100 psig inlet pressure.

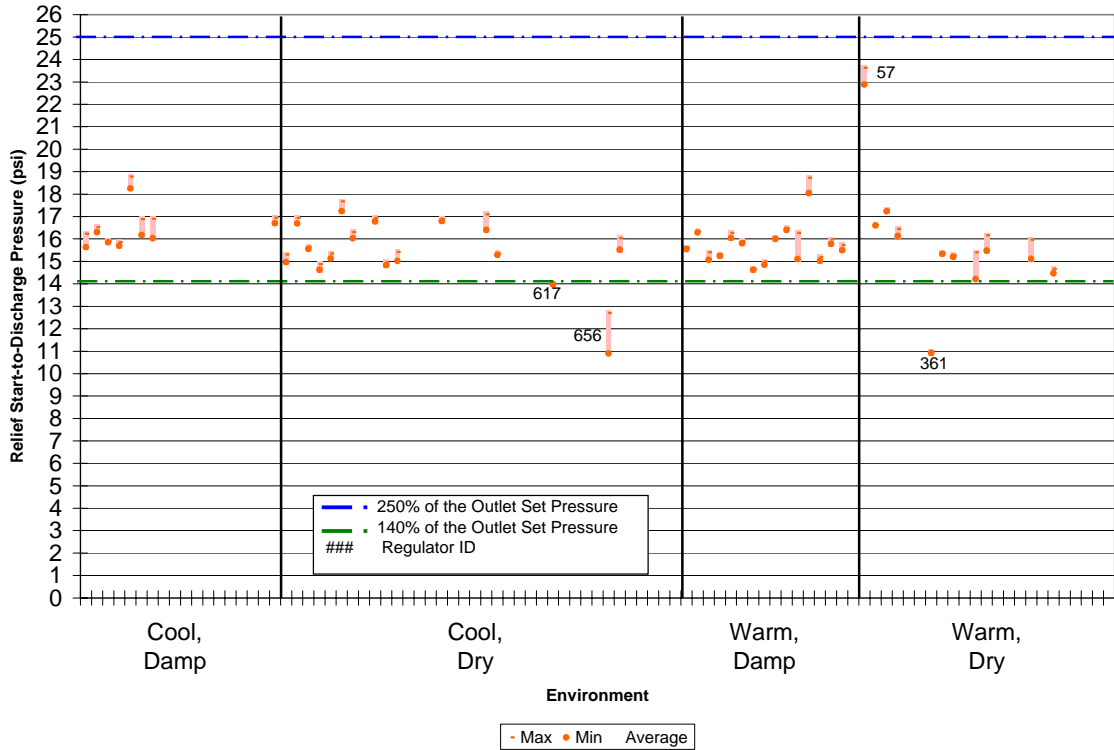

Figure 63. Start-to-discharge pressures and environment for 10 psi first-stage regulators.

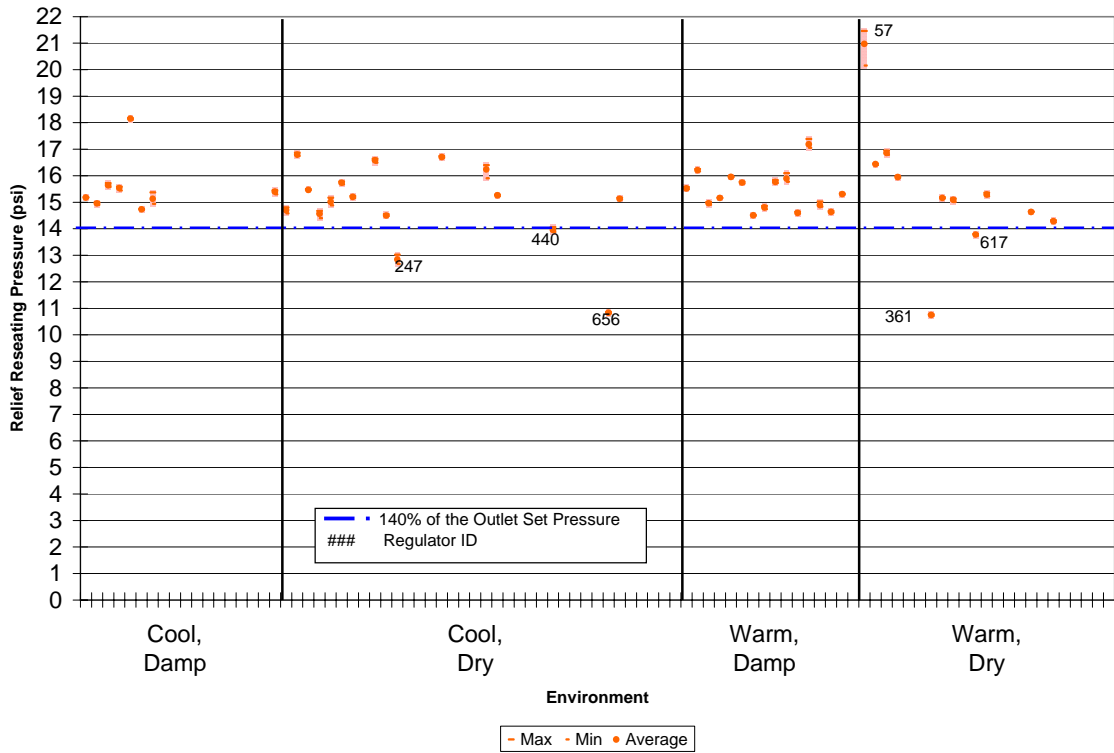

Figure 64. Reseat pressures and environment for 10 psi first-stage regulators.

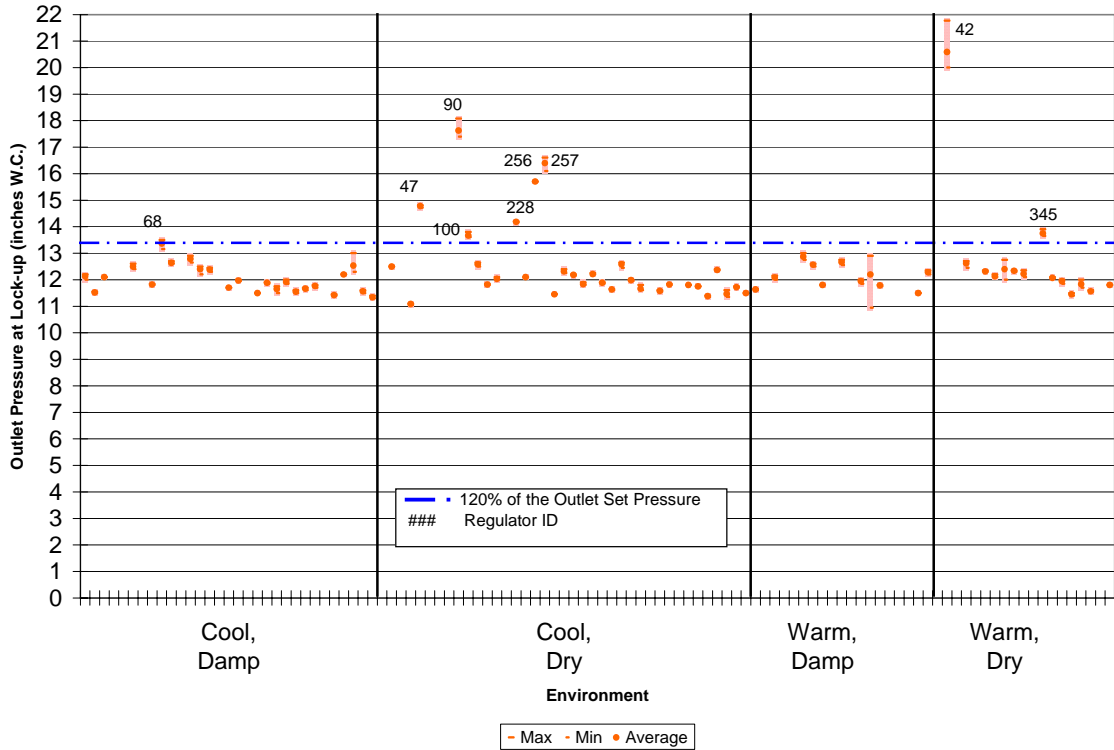

Figure 65. Lock-up pressures and environment for second-stage regulators at 10 psig inlet pressure.

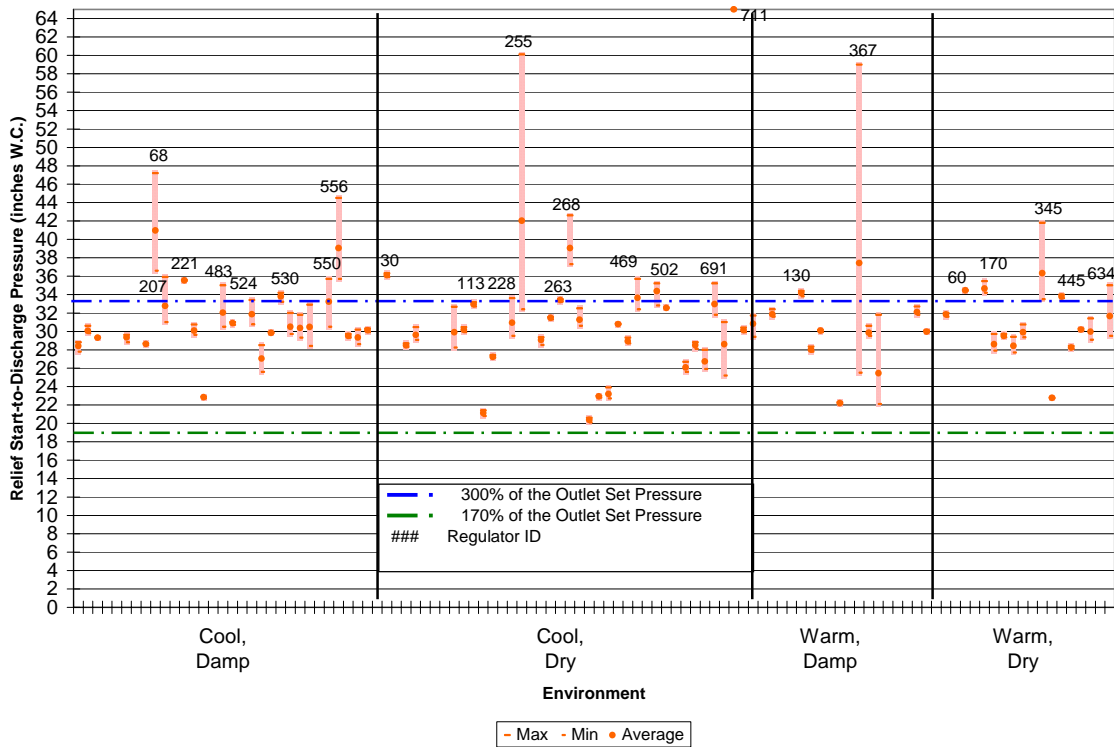

Figure 66. Start-to-discharge pressures and environment for second-stage regulators.

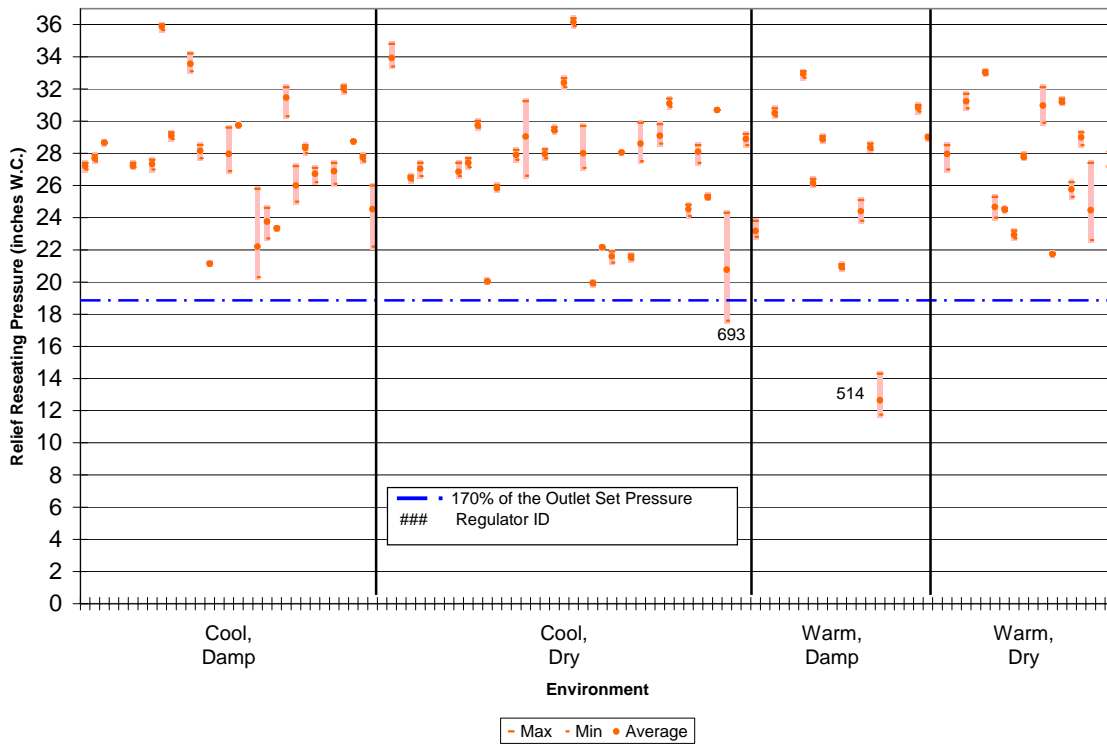

Figure 67. Reseat pressures and environment for second-stage regulators.

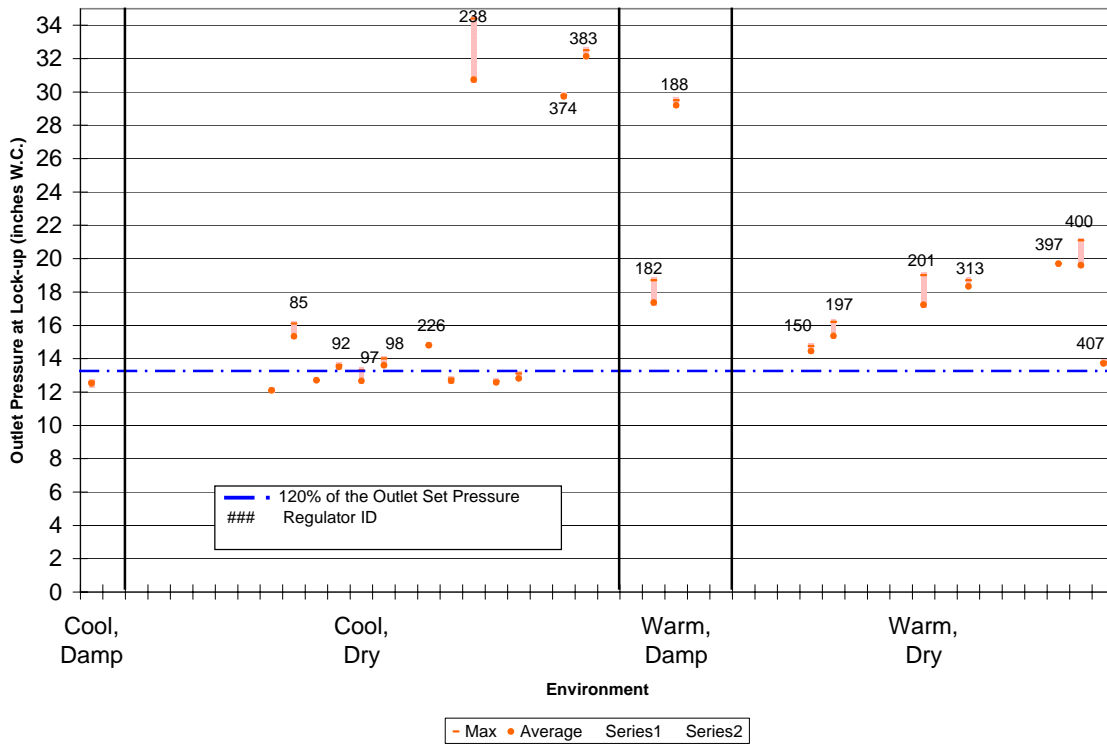

Figure 68. Lock-up pressures and environment for single-stage regulators at 100 psig inlet pressure.

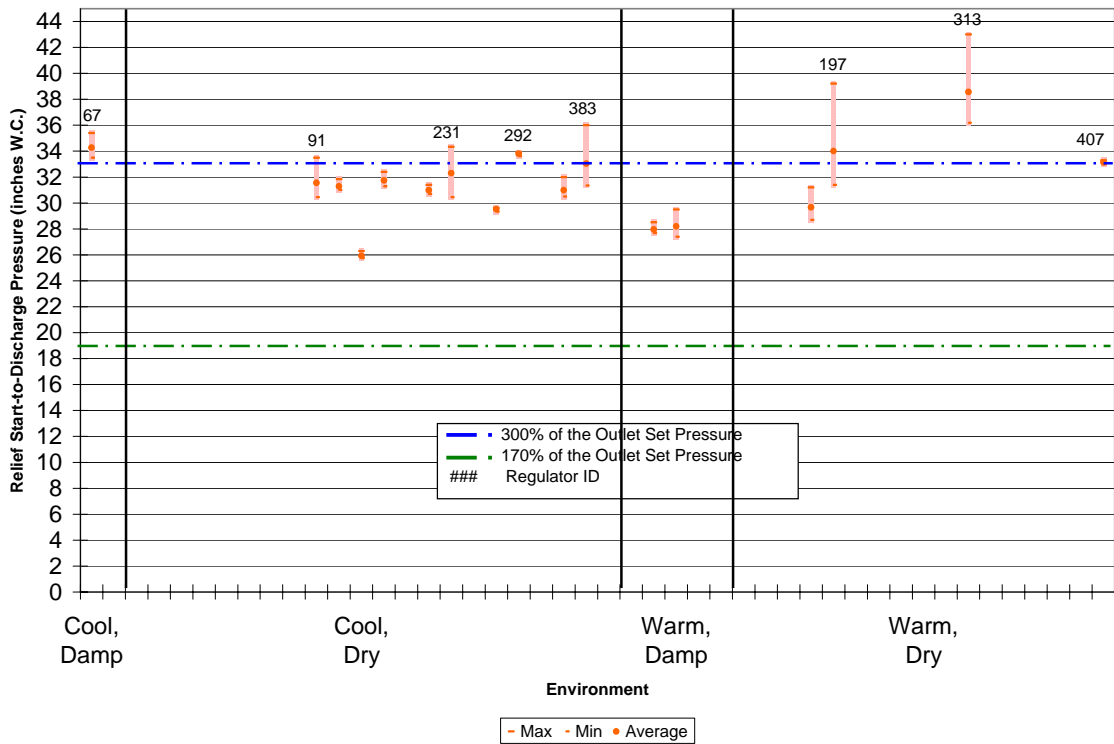

Figure 69. Start-to-discharge pressures and environment for single-stage regulators.

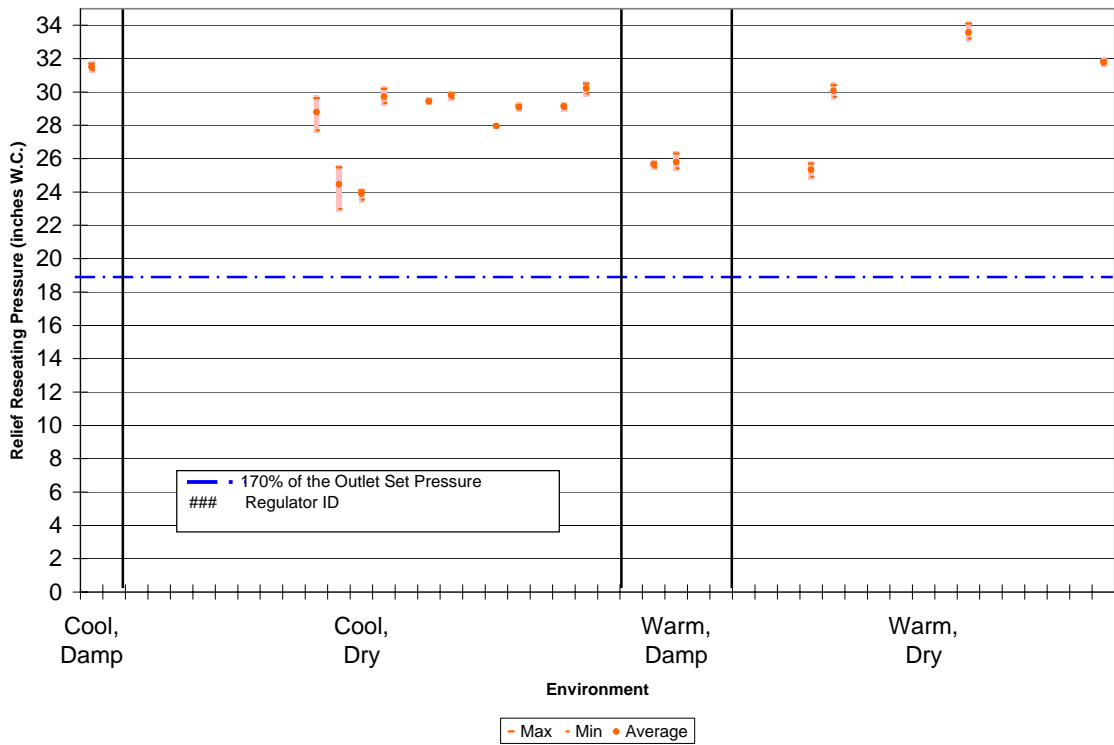

Figure 70. Reseat pressures and age for single-stage regulators.

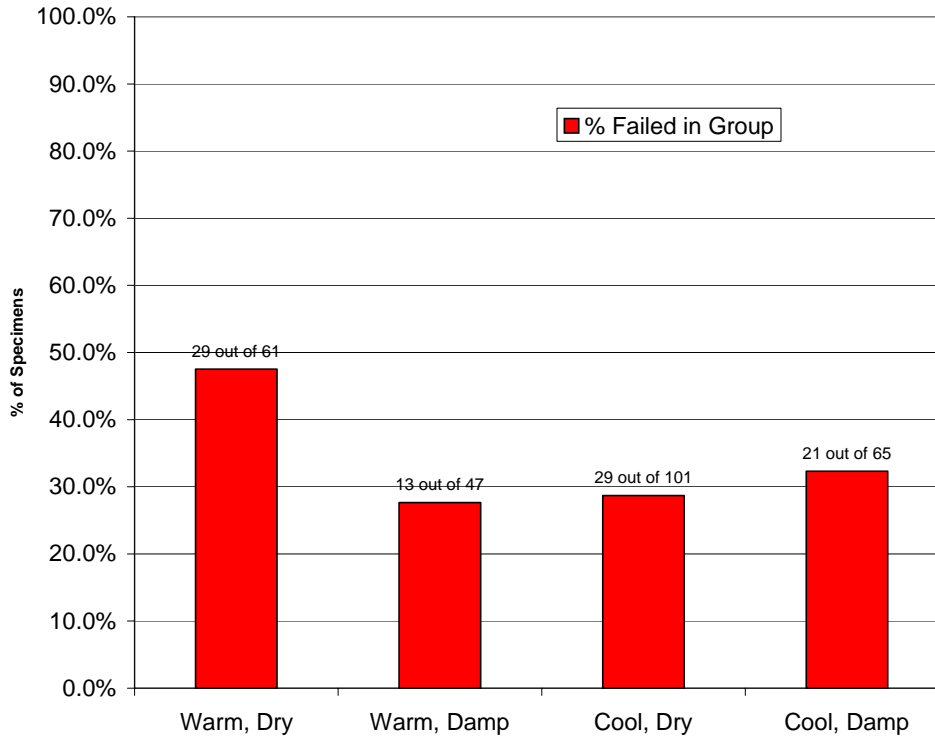

Figure 71. Regulator failures by regulator environment.

5.3.5 Causes of Regulator “Failures”

Identification of regulator failures was based on potential safety concerns related to system overpressurization and/or leaking gas. As such, the main causes of regulator failure identified in this test program include:

- Regulator chatters and leaks through the pressure relief device (PRD);
- Leak in regulator body;
- PRD start-to discharge and/or reseal pressure too low;
- PRD start-to discharge pressure above the UL 144 specification;
- Regulator discharge pressure will not stabilize; or
- PRD did not relieve.

Additionally, a total of 5 regulators selected for testing were missing the bonnet cap. The bonnet cap protects the regulator from contaminants entering the regulator and damaging the diaphragm and/or creating corrosion problems. Since there was not a means to determine if problems associated with these regulators were due to the regulator itself or damage caused from the missing bonnet cap it was decided not to include test results for these regulators.

Some regulators also exhibited lock-up pressures beyond the limits specified in UL 144 as shown in Section 5.3.1; however this result was not considered as a regulator failure. The belief is that even though the regulator is not functioning within the limits of a new regulator it may still be fit for service. Over time, the elastomer material in the seat disc is likely to permanently indent/deform from repeated opening and closing of the regulator. This permanent deformation of the seat disc may lead to a larger range in the regulator pressure performance curve but is not likely to lead to significant operational or safety issues. These regulators have been noted as such in the test results documentation. However, if the seat disc is permanently deformed to the point that it will not close, the regulator will exhibit very high lockup or may not lockup at all. In this circumstance, the relief device may open to prevent overpressurization in the regulator outlet. If this occurs on two or three of the lockup tests, the regulator would be marked as “failed”.

Additionally, regulators that did not meet the UL 144 pressure relief criteria (for new regulators) in only one of three trials were not considered a failure. Often, for the older regulators, the start-to-discharge pressure in the initial trial was significantly higher than the subsequent trials indicating that the relief valve seat was stuck in place. The sticking of the relieve valve on older units was observed in a previous project on cylinder relief valves¹. Once the pressure was high enough to overcome the adhesion force, the relief valve opened. As such, the remaining two trials relieved at much lower pressures because the relief valve seat was no longer stuck in place. These regulators were documented in the results tables but were not included in the “failure” tally. A summary of the test results for these failed regulators is shown in Table 15. Figures 72 through 75 provide the distribution of regulator failures (based on the causes listed above) compared to the number of regulators tested for the various regulator types, manufacturers, ages, and environmental conditions. Exact numbers are provided in Tables 16 through 19.

¹ Stephens, D.R., Gifford, D.R., Francini R.B., Mooney, D.D., CG-7 Pressure Relief Valve and Propane Cylinder Performance, NPGA, January 2003.

This page intentionally left blank.

This page intentionally left blank.

Table 16. Regulator failures by type.

Reason for Failure	1st Stage	2nd Stage	Integral Two-Stage	Single-stage	Total
Chatters and leaks through regulator PRD	9	10	8	10	37
Leak in regulator body	2	1			3
PRD start-to discharge and/or reseal pressure too low	5	1			6
PRD start-to discharge pressure too high		16	2	4	22
Outlet pressure will not stabilize	9	1		7	17
PRD did not relieve		1	1		2
Total	25	30	11	21	87
Total Tested	111	102	21	32	266
% Failed in Group	22.5%	29.4%	52.4%	65.6%	

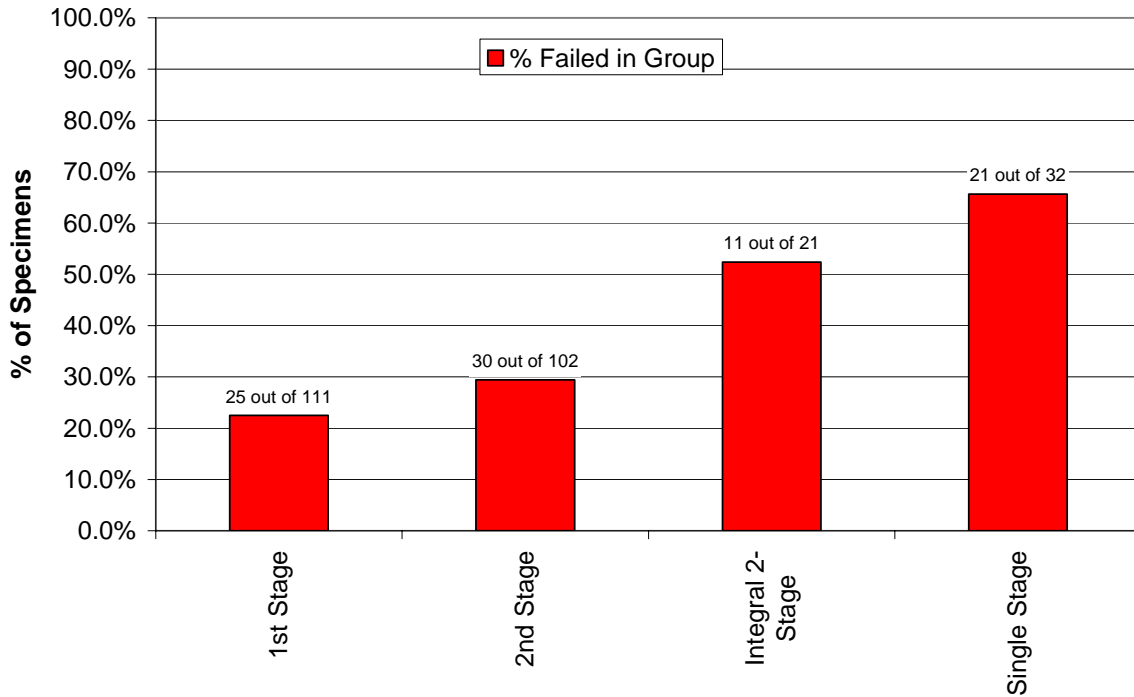

Figure 73. Regulator "failures" by type of regulator.

Table 17. Regulator failures by manufacturer.

Reason for Failure	Manuf. A	Manuf. B	Other	Total
Chatters and leaks through regulator PRD	17	20		37
Leak in regulator body	1	2		3
PRD start-to discharge and/or reseal pressure too low	1	5		6
PRD start-to discharge pressure too high	11	11		22
Outlet pressure will not stabilize	8	9		17
PRD did not relieve	2	0		2
Total	40	47	0	87
Total Tested	139	127	0	266
% Failed in Group	28.8%	37.0%	0%	

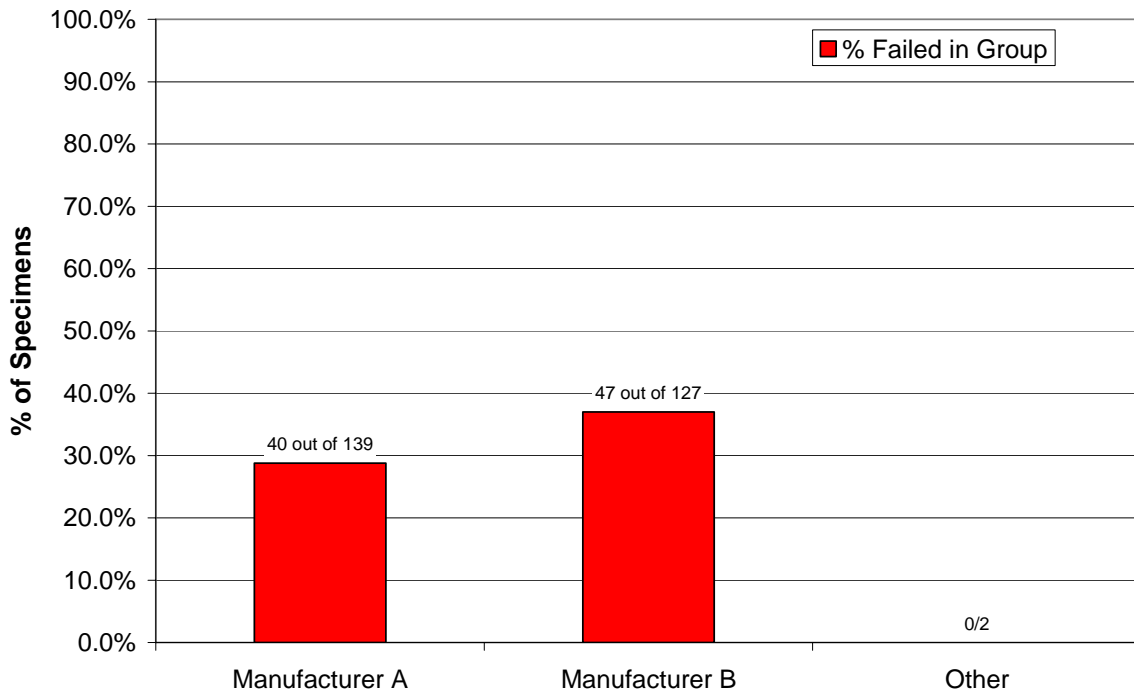

Figure 73. Regulator "failures" by regulator manufacturer.

Table 18. Regulator failures by age.

Reason for Failure	0-5	6-10	11-15	16-20	21-25	26-30	31-35	36-40	41-45	46-50	51-55	56-60	Total
Chatters and leaks through regulator PRD	1	9	7	8		3		2	1	5	1		37
Leak in regulator body	1	1	1										3
PRD start-to discharge and/or reseal pressure too low	1	3	1			1							6
PRD start-to discharge pressure too high	1	1	5	3	3	3	3	2	1				22
Outlet pressure will not stabilize			5		3	2	1	1	3	1		1	17
PRD did not relieve		1				1							2
Total	4	15	19	11	6	10	4	5	5	6	1	1	87
Total Tested	29	49	50	37	20	23	15	11	15	12	2	1	266*
% Failed in Group	13.8	30.6	38.0	29.7	30.0	43.5	26.7	45.5	33.3	50.0	50.0	100	

*Two regulators of unknown age in the test sample; however, neither failed the test criteria.

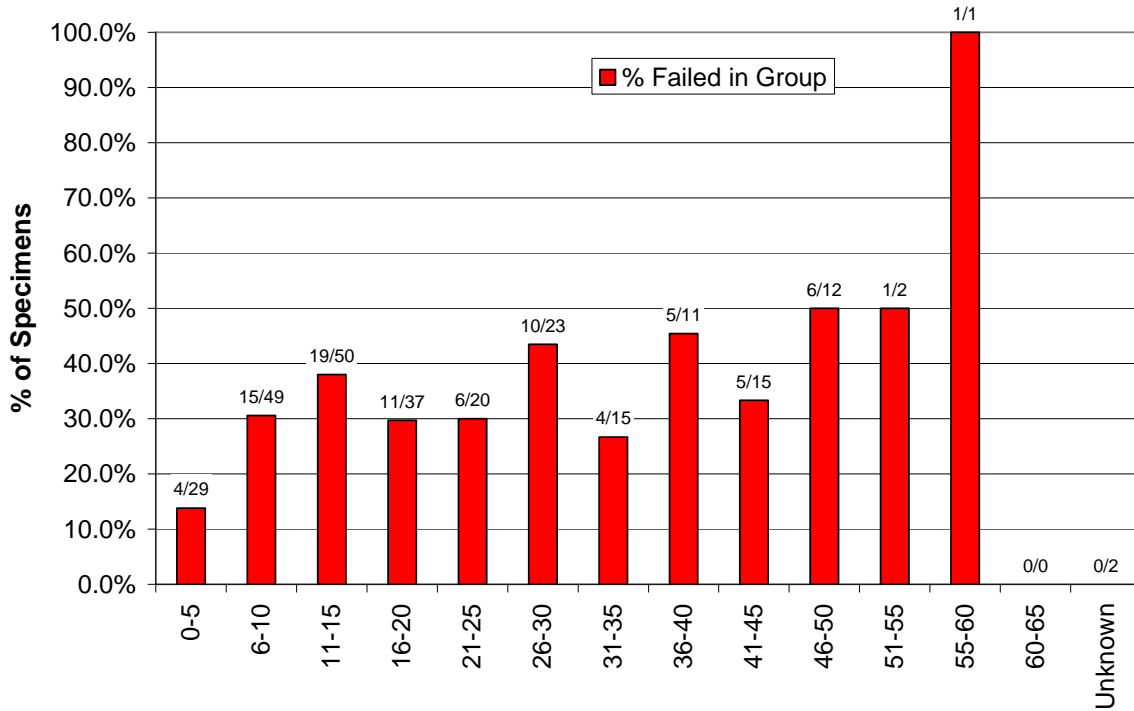

Figure 74. Regulator "failures" by regulator age.

Table 19. Regulator failures by environmental condition.

Reason for Failure	Warm, Dry	Warm, Damp	Cool, Dry	Cool, Damp	Total
Chatters and leaks through regulator PRD	12	6	10	9	37
Leak in regulator body			2	1	3
PRD start-to discharge and/or reseal pressure too low	2	1	3		6
PRD start-to discharge pressure too high	7	2	6	7	22
Outlet pressure will not stabilize	5	3	6	3	17
PRD did not relieve	1		1		2
Total	27	12	28	20	87
Total Tested	59	46	98	63	266
% Failed in Group	45.8%	26.1%	28.6%	31.7%	

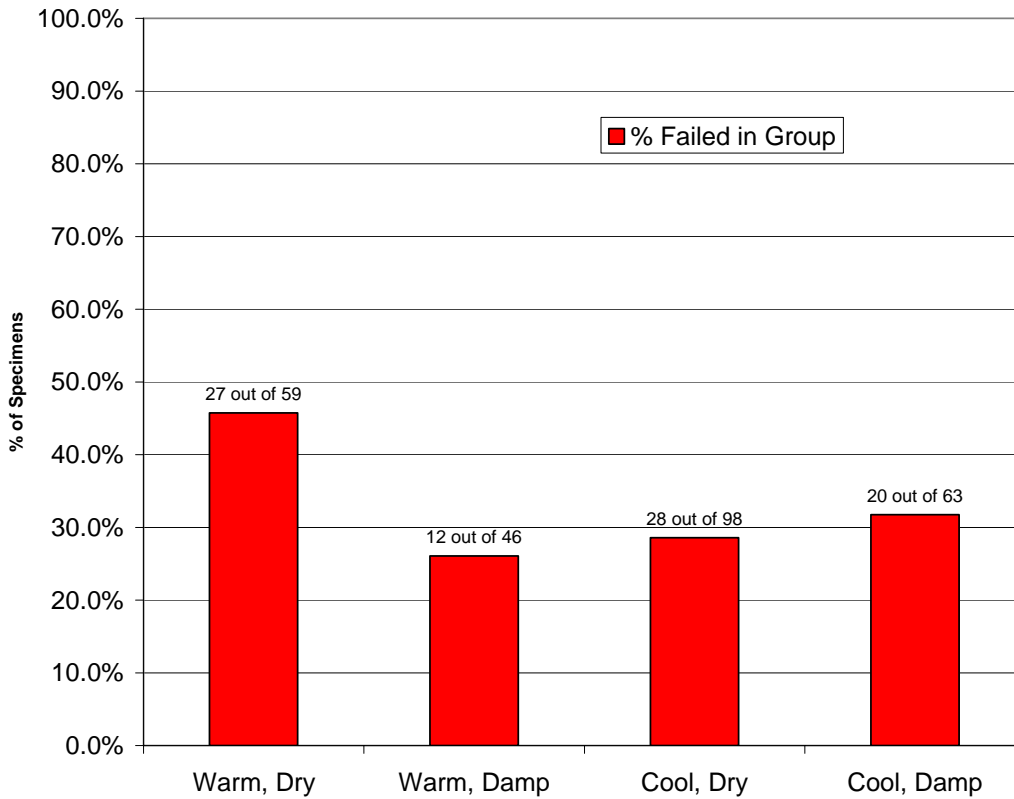

Figure 75. Regulator "failures" by type of environment.

The percentage of failures for all categories ranged from a low of 14% in the 0 to 5-year age range to a high of 100% in the 55 to 60-year age range. A majority of the categories had failure rates around 30% with regulators from warm, dry regions and regulators above the age of 45 having approximately a 50% failure rate. Integral two-stage regulators had failure rates over 50% and single-stage regulators had failure rates near 65%.

The largest cause of regulator failure, with 37 regulators that failed, was regulators that chattered and leaked through the PRD. The second largest cause of regulator failure, with 22 regulators that failed, was regulators with PRD start-to-discharge pressures that were too high. Both these failure mechanisms possibly indicate that the conditions under which the regulators were tested may have been more severe than what is typically seen out in the field. A flowrate of 80 cfh is higher than a normal household application, and this high flowrate may have contributed to the failures identified in this study. Additionally, tank pressures of 250 psig, which would be the inlet pressure for first-stage, single-stage, and integral two-stage regulators, are not likely to occur and may have also stressed these regulators beyond the limits of normal operation. While these parameters were higher than would be experienced in normal operation, these maximums are not beyond the design specifications of new regulators.

This page intentionally left blank.

6.0 INSPECTIONS OF “FAILED” REGULATORS (TASK 3)

Several of the regulators identified as “failures” were selected for detailed failure analysis to determine possible failure mechanisms and environmental variables that contributed to the failure. The failure analysis selection process was not intended to be statistically-based as was the testing selection process. The selection was subjective, and an attempt was made to select samples that had a range of reasons for not meeting the UL 144 performance requirements, a range of environmental conditions, a range of ages, and a balance of the two predominant manufacturers. The regulators selected for failure analysis are presented in Table 20 with detailed analyses provided in Appendix C.

Table 20. Regulators selected for failure analysis.

Regulator ID	Manuf.	Age	Climate	State	Service Area	Reason for Removal	Reason for Not Meeting UL Criteria
13 (2-stage)	A	13	Warm, Damp	AL	Rural	Faulty regulator; no pressure at regulator outlet	High lock-up pressure
42 (second)	B	16	Warm, Dry	IL	Suburban	End of manuf. recom. service life	High lock-up pressure
72 (second)	A	16	Cool, Dry	CO	Rural	Tank and regulator removed from service	Chatters and leaks through PRD at 10 psig inlet pressure and 30 cfh.
353 (single)	A	15	Warm, Damp	MS	Rural	End of manuf. recom. service life	Chatters and leaks through PRD at 100 psig inlet pressure and 30 cfh.
361 (first)	B	27	Warm, Dry	CA	Urban	Tank and regulator removed from service	PRD start-to-discharge and reseating pressures too low; dirty exterior; clean interior; could not adjust
383 (single)	B	43	Cool, Dry	SD	Rural		PRD start-to-discharge pressure too high in first trial; high lock-up
490 (2-stage)	B	6	Warm, Damp	FL	Suburban	Changed from single to dual regulator system	Chatters and leaks through PRD at 100 psig inlet pressure and 30 cfh.
538 (first)	A	16	Warm, Dry	PA	Suburban	Tank and regulator removed from service	Leak through PRD at 25 psi inlet pressure and 0 cfh; high lock-up pressure
571 (first)	B	10	Cool, Damp	MI	Rural	Faulty regulator	Leaked through PRD during adjustment
711 (second)	A	27	Cool, Dry	SD	Rural	End of manuf. recom. service life	PRD did not relieve after reaching 65" W.C.

Findings from the failure analysis indicate a few possible trends as to why some regulators did not meet the test criteria. In particular, the second-stage regulator 711 did not relieve because of excessive dirt and spider webs blocking the relief opening (Figure 76). This is not a manufacturing issue but rather a maintenance or installation issue and would not be indicative of

any problems related to regulator age, environment, or manufacturer. This problem is not expected for regulators that are properly inspected and maintained.



Figure 76. Regulator 711 — blocked pressure relief.

For the regulators that were disassembled and analyzed, debris within the regulator body was the single most common potential cause for high regulator lock-up and/or leaks through the PRD (regulators 13, 72, 353, and 571). Some of the debris found appears to be corrosion products (from piping or containers), but other debris appears to be related to regulator manufacturing. For example, first-stage regulator 571 contained machining turnings inside the body of a regulator, with some pieces stuck on the control disk seat (Figure 77, circled). This debris was too large to get through the inlet screen of the regulator and appeared to be from the regulator manufacturing process.



Figure 77. Regulator 571 — machining turnings found inside regulator.

Other regulators (42 and 383) showed some damage to the regulator seat disc which could have led to high lock-up pressures. For example, single-stage regulator 383 appeared to be in good condition during initial external and internal (visual through the bonnet opening) examinations. However, when examined more closely significant degradation of the seat disc was found (Figure 78). The seat disc appeared to have material losses more significant than what would be expected solely from the compression set. Compression set is the permanent deformation of an elastomer after it has been compressed for an extended period of time. In addition, a significant amount of debris was found between the orifice and seat disc which could be attributed to the material lost from the seat disc. While this degradation is significant, this regulator was 43 years old when removed from service. This unit was in service well beyond the recommended service life of either the 15-year period or the more recent periods of 20 or 25 years.



Figure 78. Regulator 383 — seat disc.

For several other regulators (361, 490, and 538) no specific cause for the regulator “failure” could be determined. Possible causes included a slash on the diaphragm and a scratch on the regulator shaft that mates with the o-ring seal, however all other locations within the regulator body appeared to be in working order and free from significant debris.

This page intentionally left blank.

7.0 CONCLUSIONS

The objective of this program was to determine if there were bases for a recommended service life of 15 years for propane regulators. The program considered information gathered from the technical or manufacturers' literature and from tests performed on a sample of regulators removed from service. Seven hundred seventy-three regulators were received from marketers across the United States, varying in age from less than one year to more than sixty years. A sample of 266 regulators was selected from the overall population received, and these 266 were tested to a protocol that was developed based on UL 144, Pressure-Regulating Valves for LP-Gas. Outlet pressures for two gas flow rates, lock-up pressures, PRD start-to-discharge pressures and PRD reseat pressures were measured on the tested regulators.

7.1 Literature Survey

A review of U.S. manufacturers' literature found that three manufacturers have recently increased the recommended service life of their regulators from 15 years to 20 or 25 years (depending on the specific manufacturer). The manufacturers' literature did not explicitly cite the reason for the increase in recommended service life, but the literature identified design features that influence service life, include corrosion resistant relief valve seats, stainless steel relief valve springs and retainers, and painted, heavy-duty zinc bodies and bonnets.

One technical paper was found that directly considered aging effects on propane vapor regulators. The paper discussed a study of regulators in Korea, which showed that in general the safety devices of the low pressure regulators deviated from normal operation after a year of service and deviated from the discharge start and reset pressures of the new regulators. Testing of diaphragms from the propane regulators in the field found a loss of tensile strength and decreased range of motion after five years of service. Researchers suspect a hardening of the diaphragms due to leaching of plasticizers from rubber materials over time. The paper also discussed the testing of propane regulator springs, which found a loss in tensile strength after seven years of service. This study recommended a six-year service life. There is no evidence that this recommendation was implemented in Korea. It should be noted that none of the regulators tested were from U.S. manufacturers. However, the Korean study does raise the issue of the long-term effects of a propane operating environment has on elastomer and spring performance.

Technical references were identified that discussed the leaching various constituents, such as plasticizers and extenders, from elastomeric components. References were also identified that discuss the compositional variability of propane in the U.S.

The findings of the literature review suggest further research in the use and variability of plasticizers and extenders in the rubber composition of propane regulator components; the long-term effect a propane operating environment has on elastomer and spring performance; and the effect of propane contaminants and off-specification gas on propane regulator performance.

7.2 Effects of Age on Regulator Performance

Age appears to have little effect on the performance of first-stage regulators, and only a slight effect on the performance of second-stage regulators. On the other hand, age appears to have a significant effect on the performance of single-stage regulators; however, the sample size for this group was much smaller than the other groups, and therefore the results are less statistically significant. Aside from the mechanical differences that provide the pressure control ranges of the three main types (first, second, and single-stage), these types have several components in common – flexible, elastomeric diaphragm, elastomeric seat disc, steel springs, and mechanical linkage. All regulator types use elastomers in similar functions (seals, diaphragms, seat discs), so degradation of the elastomers would affect all types of regulators. The single-stage unit must control over a larger pressure ratio. A first-stage regulator, with a design inlet pressure of 250 psi and a nominal outlet pressure of 10 psi, and a second-stage regulator, with a nominal inlet pressure of 10 psi and a nominal outlet pressure of 11 inches of water, each have a pressure controlling ratio of approximately 25 (inlet pressure ÷ outlet pressure). Single-stage regulators have a design inlet pressure of 250 psi and a nominal outlet pressure of 11 inches of water, which is a pressure controlling ratio of approximately 630. This wide pressure-control requirement may make the single-stage units more susceptible to elastomer degradation and any corrosion on the metallic linkage parts.

The testing did identify some issues related to age. Some regulators also exhibited lock-up pressures beyond the limits specified in UL 144; however this result was not considered as a regulator failure. The belief is that even though the regulator is not functioning within the limits of a new regulator it may still be fit for service. Over time, the elastomer material in the seat disc is likely to permanently indent/deform from repeated opening and closing of the regulator. This permanent deformation of the seat disc may lead to a larger range in the regulator pressure performance curve but is not likely to lead to significant operational or safety issues. These regulators have been noted as such in the test results documentation. However, if the seat disc is permanently deformed to the point that it will not close, the regulator will exhibit very high lockup or may not lockup at all. In this circumstance, the relief device may open to prevent overpressurization in the regulator outlet. If this occurs on two or three of the lockup tests, the regulator was marked as “failed”.

Additionally, regulators that did not meet the UL 144 pressure relief criteria (for new regulators) in only one of three trials were not considered a failure. Often, for the older regulators, the start-to-discharge pressure in the initial trial was significantly higher than the subsequent trials indicating that the relief valve seat was stuck in place. The sticking of the relieve valve on older units was observed in a previous project on cylinder relief valves. Once the pressure was high enough to overcome the adhesion force, the relief valve opened. As such, the remaining two trials relieved at much lower pressures because the relief valve seat was no longer stuck in place. These regulators were documented in the results tables but were not included in the “failure” tally.

In this study, the key observation is that the two-stage regulator systems currently used show no significant degradation during the 20- to 25-year period of service that is now standard.

7.3 Effects of Manufacturer on Regulator Performance

The numbers of regulators tested were fairly evenly distributed between two manufacturers, “A” and “B”, with over 125 units tested from each manufacturer. The test data of lockup pressures, relief start-to-discharge pressures, and relief reseal pressures do not show a noticeable variation of the data points taken as a group (considering all regulators tested of one manufacturer), or in the variability of a particular regulator. This is a good indicator that there is no significant difference in the data between the manufacturers.

7.4 Effects of Environment on Regulator Performance

The test data were compared from the perspective of the four environmental regions:

- Warm; dry ($\geq 53^{\circ}\text{F}$; $< 73\%$ humidity),
- Warm; damp ($\geq 53^{\circ}\text{F}$; $\geq 73\%$ humidity),
- Cool; dry ($< 53^{\circ}\text{F}$; $< 73\%$ humidity), and
- Cool; damp ($< 53^{\circ}\text{F}$; $\geq 73\%$ humidity).

The source environment comparison shows fairly consistent behavior in pressure tests of lock-up, PRD start-to-discharge, and PRD reseal across each environment. However, when the failure rates for the four environmental conditions are compared, a higher percentage of failures is documented for regulators received from a warm, dry environment. With the number of samples being reasonably significant (much greater than ten units), the fact that nearly half of the warm, dry regulators failed to meet the test criteria is also significant. Although internal and external corrosion may be considered a significant failure mechanism, the drying effects on elastomeric components such as seals and the diaphragm may be more significant. As noted earlier, more research is needed to clarify the effects of propane and its constituents and contaminants on elastomers.

7.5 Inspections of “Failed” Regulators

For the regulators that were disassembled and analyzed, debris within the regulator body was the single most common potential cause for high regulator lock-up and/or leaks through the PRD. Some of the debris found appears to be corrosion products (from piping or containers), but other debris appears to be related to regulator manufacturing. Other regulators showed some damage to the regulator seat disc that could have led to high lock-up pressures.

For several other regulators no specific cause for the regulator “failure” could be determined. Possible causes included a slash on the diaphragm and a scratch on the regulator shaft that mates with the o-ring seal; however, all other locations within the regulator body appeared to be in working order and free from significant debris.

APPENDIX A

Literature Review of Low Pressure Propane Vapor Regulators by GTI

LITERATURE REVIEW
OF
U.S. LOW PRESSURE, PROPANE VAPOR REGULATORS
GTI# 20132.1.01/ PERC Docket 11073

Prepared for:
Propane Education and Research Council (PERC)
1140 Connecticut Ave., NW, Suite 1075
Washington DC 20036
November 2005

Literature Review of Regulator Service Life

[Intentionally Blank]

Literature Review of Regulator Service Life

LEGAL NOTICE: This report was prepared by the Gas Technology Institute as an account of work sponsored by Propane Education and Research Council (PERC). Neither PERC nor any person acting on their behalf:

- a. Makes any warranty or representation, express or implied, with respect to the accuracy, completeness or usefulness of the information contained in this report, or that the use of any information, apparatus, method, or process disclosed in this report may not infringe privately owned rights; or
- b. Assumes any liability with respect to the use of, or for any and all damages resulting from the use of, any information, apparatus, method or process disclosed in this report.

Literature Review of Regulator Service Life

[Intentionally Blank]

Literature Review of Regulator Service Life

Table of Contents

Summary Findings	1
Overview.....	3
Background.....	3
Objective.....	3
Approach.....	3
Literature Search Results	4
Elastomers.....	4
Metals.....	6
Propane Composition.....	7
Codes & Standards Review	9
US Regulator Manufacturing Literature Review	12
Fisher Regulators	13
RegO [®] Regulators.....	19
Sherwood Regulators.....	25
Conclusions.....	31
References.....	32

Tables

Table 1 GPA Liquefied Petroleum Gas Specifications.....	7
Table 2 Typical Trace Contaminants Found in LP-Gas	8
Table 3 Fisher LP-Gas Regulators.....	13
Table 4 Fisher Propane Regulator Service/Safety Bulletins.....	16
Table 5 RegO [®] LP-Gas Regulators.....	19
Table 6 Component Materials by RegO [®] Regulator Series.....	20
Table 7 Component Materials by RegO [®] Regulator Series.....	20
Table 8 RegO [®] Propane Regulator Service/Safety Literature Search Results	22
Table 9 Sherwood LP-Gas Regulators.....	25
Table 10 Sherwood Propane Regulator Service/Safety Bulletins.....	28

Literature Review of Regulator Service Life

Summary Findings

Two propane regulator manufacturers have extended the service-life recommendation of some propane regulators, and a third manufacturer is contemplating the same. A literature review was important to determine if there was scientific or engineering support for a 15-year replacement recommendation.

- The literature review was not able to document scientific or engineering support for a service-life recommendation of 15-years or greater. The findings of the literature review warrant further research in the use and variability of plasticizers and extenders in the rubber composition of LPG regulator components; the long-term effect a propane operating environment has on elastomer and spring performance; and the effect of LP-Gas contaminants and off-specification gas on U.S. LPG regulator performance.
- In “Aging Characteristics of Low Pressure LPG Regulators for Domestic Use”, (Kim, Kwon 1999) results showed that in general the safety devices of the low-pressure regulators deviated from normal operation after a year of service and deviated from the discharge start and reset pressures of the new regulators. Overall, the operating and closing pressures also deviated from the pressure range of the new regulators after a year of service. A 6 year service life was determined:
 - Testing of diaphragms from the LPG regulators in the field found a loss of tensile strength and decreased range of motion after 5 years of service. Researchers suspect a hardening of the diaphragms due to leaching of plasticizers from rubber materials over time. The authors called for further research to improve diaphragm durability and reliability, to investigate the effect of plasticizer extraction from rubber materials on diaphragm performance, and the development of new rubber materials with improved rubber characteristics and properties.
 - Testing of LPG regulator springs from the field found a loss in tensile strength after a 7 year service life. The authors called for spring research on the length of the freedom field of the spring, the surface treatment on the ending parts of the spring, quality control in the manufacturing, and reinforcement of durability characteristics.
 - None of the regulators tested were from U.S. manufacturers. Research is warranted to investigate the long-term effect a propane operating environment has on elastomer and spring performance.
- A review of elastomers reference literature, “The Vanderbilt Rubber Handbook -13th Edition”, (Ohm, 1990), and “Rosato’s Plastics Encyclopedia and Dictionary” (Rosato, 1993), found that additives, particularly plasticizers and extenders, can leach out over time, resulting in physical changes in size, elongation, and tear strength. In regulators, elastomers are used in valve seat discs and diaphragms. Research is warranted to assess the use and variability of plasticizers and extenders in the rubber composition of LPG regulator components.

Literature Review of Regulator Service Life

- In “Investigation of Portable or Handheld Devices for Detecting Contaminants” (Hutzler, Johnson 2005), findings indicate that while LP-Gas for domestic use meets commercial grade specifications, contamination occurs in small quantities in the supply chain over time. Further, the impact of propane contaminants and off-specification gas is not well documented. Research is warranted to investigate the effect of LP-Gas contaminants and off-specification gas on U.S. LPG regulator performance.
- Underwriters Laboratories’ UL 144 LP-Gas Regulators is the current performance standard for LP-Gas regulators and is designed for new regulators, not regulators that have been in the field. UL 144 is silent on the issue of service or useful life. Test requirements for materials in UL 144 are found in American Society of Testing and Materials (ASTM) standards that are designed to be an indicator of long-term performance.
- Codes and standards that reference UL 144, including NFPA 54: National Fuel Gas Code, NFPA 58: Liquid Petroleum Gas Code and ANSI Z21.18a-2001/CSA 6.3a Gas Appliance Pressure Regulators are silent on useful or service life of LPG system components.
- A review of U.S. manufacturers’ literature found:
 - RegO[®] recommends regulator service life of 25 yrs for regulators (except single-stage) manufactured after 1995; all other regulators have a service life of 15 years.
 - Fisher recommends regulator replacement at 20 years, or over 15 years of age for regulators that have experienced conditions (corrosion, underground systems, flooding, etc.) that would shorten their service life.
 - Sherwood recommends regulator replacement after 15 years; however, in email correspondence with a Sherwood representative, a 25 year life on some models was quoted.
- Typical materials identified in the literature that are used in LPG regulators include zinc or die cast aluminum bodies, chromate coatings, nitrile rubber and other synthetic polymers, and stainless steel springs.
- Service life attributes, or manufacturers’ stated features that influence service life, include corrosion resistance coatings and stainless steel relief valve spring and retainer, and a corrosion resistant relief valve seat (Fisher); stainless steel relief valve spring and retainer (Fisher); and painted, heavy-duty zinc (body and bonnet) resists corrosion and gives long-life protection, even under “salty air” conditions. (RegO[®]).
- All three manufacturers’ literature reference National Propane Gas Association (NPGA) documents in discussions related to installation, inspection, maintenance, and safety. NPGA no longer supports these documents and has released these documents to the public domain provided that they are not attributed to NPGA. Discontinued documents that are referenced include:
 - NPGA Installation and Service Guide Book #4003,
 - NPGA Propane Safety and Technical Support Manual Bulletin T403,
 - NPGA Safety Pamphlet 306 “LP-Gas Regulator and Valve Inspection and Maintenance”,

Literature Review of Regulator Service Life

- NPGA LPG Safety Handbook #0001, and
- NPGA Bulletin #133-80.

These documents can no longer be referenced as NPGA documents and effort should be made by the manufacturers to acknowledge and correct this within their product literature.

Overview

Background

Some propane regulator manufacturers have recently extended the service-life recommendation of some propane regulators. The propane industry deemed it important to determine if there was scientific or engineering evidence to support a greater than a 15-year replacement recommendation, as well as for the recently extended service life recommendation for some models.

GTI in its initial investigation of pertinent research found that the Gas Safety R&D Center of the Korea Gas Safety Corporation had conducted research on the aging characteristics of low-pressure LPG regulators in the 1990s. In evaluating how time affected performance characteristics and service life, researchers found deterioration in the material properties, most notably springs and diaphragms, after 5-6 years of service. Details regarding this testing are discussed in more detail under the section on Literature Search Results.

Based upon this information, research was warranted to investigate what service life the propane industry can expect from the regulators already in use.

Objective

The objective of this research was to provide an annotated review of available information worldwide on low-pressure propane regulators with focus on recommended service life and to the extent possible the basis for cited recommendations.

Approach

U.S. manufacturers market low-pressure propane/LPG regulators worldwide. These regulators are constructed to comply with U.S. standards and then separately certified for use in overseas markets. For this reason, the focus of this review was on U.S. manufacturers, specifically the three companies that occupy a majority of the regulator market share: Fisher, RegO[®], and Sherwood.

GTI reviewed manufacturers' literature from Fisher, RegO[®], and Sherwood and concentrated on additional research conducted by the Korean Gas Safety Corporation. In addition, GTI reviewed relevant codes and standards, and reviewed the abstracts of peer-reviewed research on materials. GTI supplemented this review with follow-up discussion with materials and analytical personnel, and with the regulator manufacturers.

Literature Review of Regulator Service Life

Literature Search Results

This section presents findings of GTI's literature search. Areas of focus include elastomers, metals, propane composition, codes and standards, manufacturer's literature, and missing data.

Elastomers

- A review of basic reference materials on elastomers included: "The Vanderbilt Rubber Handbook -13th Edition", (Ohm, 1990), "Rosato's Plastics Encyclopedia and Dictionary" (Rosato, 1993), and "Elastomeric Seals 101 – A Brief Tutorial", (Grethlein, Craig, Lane 2004) is summarized below.

Elastomers, or *elastic polymers*, refer to rubber and synthetic materials that exhibit high elastic behavior and is often used interchangeably with the term rubber. Synthetic rubber materials, typically a nitrile, are used in the valve seat disc and diaphragm of propane regulators. Component specifications focus on dimensions and performance characteristics, not on elastomer composition. In some cases, "branded" elastomers are specified to assure an expected product purity and performance level.

Additives are used in elastomer formulations to overcome processing issues, performance limitations, to maintain product stability or to extend the batch and increase profitability. Two additives of interest to this investigation are plasticizers and extenders.

Plasticizers are additives used to keep polymers soft and pliable. Plasticizers are physically bound in the elastomer matrix but can leach out of the material over time. This effect is dependent upon the type and quantity of plasticizer being used and the operating environment. Loss of plasticizer can result in both physical and performance changes in the materials: an increase in hardness and brittleness, and a loss in elongation. With respect to LP-Gas regulators, the loss of plasticizer can affect the performance of valve seat discs and diaphragms.

Extenders are relatively inexpensive materials that can be added to more valuable elastomers to increase the amount of material in useful form without significantly lessening the compositions properties. Extenders are similar to plasticizers in that they are physically bound in the elastomer matrix and can migrate over time effecting elastomer performance. Some plasticizers are used as extenders.

- In a Korean Gas Safety Corporation Paper, "Aging Characteristics of Low Pressure LPG Regulators for Domestic Use", (Kim, Kwon 1999) results showed that in general the safety devices of the low-pressure regulators deviated from normal operation after a year of service and deviated from the discharge start and reset pressures of the new regulators. Overall, the operating and closing pressures also deviated from the pressure range of the new regulators after a year of service. A 6 year service life was

Literature Review of Regulator Service Life

determined. The test sample included 160 low pressure LPG regulators in service from 1988 to 1997, and 6 new LPG regulators, for a total of 166 regulators tested.

Diaphragms from the LPG regulators were tested for tensile strength and elongation. Results showed a loss of tensile strength and decreased elongation after 5 years of service. Researchers suspect a hardening of the diaphragms due to leaching of plasticizers from rubber materials over time.

The paper called for further research to improve diaphragm durability and reliability, to investigate the effect of plasticizers extraction from rubber materials on diaphragm performance, and the development of new rubber materials with improved rubber characteristics and properties.

While the basic designs of the LPG regulators tested are similar to those manufactured in the U.S., none of the regulators tested were U.S. manufactured.

- “An Assessment of the Merit of Conditioning LP Gas Hoses Volume I & II”, (Battelle, 2005) documents and confirms research in France, Japan, and Canada that chemicals, mainly plasticizers, leach from hoses when in contact with LP Gas liquids.
- “Extraction Properties in LPG High Pressure Rubber Hoses”, (Kwon 2003) investigated the leaching of plasticizers in propane hoses. Findings indicate characteristic changes and failure in the butadiene rubber (NBR) used LPG high pressure regulators hoses.
- “The Effects of LPG Trace Contaminants on Rubber Properties”, (Kwon 2003) found a change in LPG regulator rubber materials when they were exposed to trace contaminants in LP-Gas composition.
- “Nitrile Rubber - Past, Present, and Future” (Hertz, Bussem, Ray 1994) cites the fact that nitrile rubber is an elastomer that has been used in the oil and gas industry for 50 years, and that there have been occasional field failures due to elastomer hardening. The paper studied the effect of different solutions on the aging process of the nitrile. Although the research couldn't duplicate low temperature field failures, they found that iron was present for all of the field failures and acted as a catalyst.

While the research focused on extreme conditions found in gas supply and processing, it raises the question of propane quality which may be an area of further investigation.

- “Investigation of the Causes of Leaks in Natural Gas Pipeline Compression Couplings” (Environ 2005) determined that aging styrene butadiene rubber (SBR) and nitrile rubber (NBR) elastomer seals, a change in natural gas composition (lower concentration of pentane and heavier hydrocarbons (C5+) compounds), and low winter temperatures contributed to the failure of elastomer seals in pipeline compression couplings.

In the above investigation, dimensional changes in elastomer seals were due to the ability of the seals to adsorb and desorb pentane, hexane, and other higher hydrocarbons found in natural gas. Related to this investigation, the research

Literature Review of Regulator Service Life

demonstrates how variability in concentrations of C5+ compounds impacts elastomer performance.

Metals

Metals used in regulators are selected based upon their ability to perform under the conditions to which they are subjected. The literature search results of pertinent information include:

- UL 144 LP-Gas Regulators specifies cadmium and zinc plating to provide resistance to corrosion. In addition, UL 144 has specific metal requirements for regulator bodies and bonnets; nonmetallic materials cannot be used. Specified metals include aluminum alloys, ductile (nodular) iron, malleable iron, high-strength grey iron Class 40B, copper alloys, steel, and zinc alloys.
- In “Aging Characteristics of Low Pressure LPG Regulators for Domestic Use” (Kim, Kwon 1999), testing of LPG regulator springs that had been in the field found a loss in tensile strength after 7 years of service life. The authors called for spring research on the length of the freedom field of the spring, the surface treatment on the ending parts of the spring, quality control in the manufacturing, and reinforcement of durability characteristics.
- “Sulfide Stress Cracking and the Commercial Application of NACE MR0175-84” (Adams, Gossett 1984) discusses materials used to avoid sulfide stress cracking (SSC) in metals. While the standard is clearly intended to be used only for oil field equipment, industry has taken MR0175 and applied it to many other areas including refineries, LNG plants, pipelines and natural gas systems. The document is constructive and identifies ways to prevent SSC failures wherever H₂S is present and includes a discussion of appropriate metals and requirements for regulator components.

Literature Review of Regulator Service Life

Propane Composition

LPG for domestic use meets commercial grade specifications as specified in both ASTM D1835 and GPA Standard 2140, listed in *Table 1*. Results from the previous discussion on elastomers, however, found variability in LPG composition and trace contaminants in LPG as possible contributors to changes in the performance of elastomers and their additives.

Table 1 GPA Liquefied Petroleum Gas Specifications

Product Characteristics	Commercial Grade	Test Method
Composition	Predominately propane and /or propylene.	ASTM D-2163-91
Vapor Pressure at 100°F, psig, max. at 37.8°C,kPa(ga), max.	208 1434	ASTM D-1267-95
Volatile residue: Temperature at 95% evaporation, °F, max. Or °C, max. Butane and heavier, liquid volume percent max. Pentane and heavier, liquid volume percent max.	-37 -38.3 2.5 ---	ASTM D-1837-94 ASTM D-2163-91 ASTM D-2163-91
Residual matter: Residue on evaporation of 100 ml, max. Oil stain observation	0.05 ml Pass ⁽¹⁾	ASTM D-2158-92 ASTM D-2158-92
Corrosion, copper strip, max.	No.1	ASTM D-1838-91(Note A)
Total Sulfur, ppmw	185	ASTM D-2784-92
Moisture content	pass	GPA Propane Dryness Test (Cobalt Bromide) or D-2713-91
Free water content	---	---
⁽¹⁾ An acceptable product shall not yield a persistent oil ring when 0.3 ml of solvent residue mixture is added to a filter paper in 0.1 increments and examined in daylight after 2 minutes as described in ASTM D-2158.		
Note A: "This method may not accurately determine the corrosivity of the liquefied petroleum gas if the sample contains corrosion inhibitors or other chemicals which diminish the corrosivity of the sample to the copper strip. Therefore, the addition of such compounds for the sole purpose of biasing the test is prohibited."		

Source: Extracted from GPA Standard 2140-97

Research funded by the PERC on handheld devices for detecting LP-Gas contaminants identified typical types of LP-Gas contaminants found in LP-Gas samples, as found in *Table 2*. Many of these contaminants can negatively impact regulator performance.

Literature Review of Regulator Service Life

Table 2 Typical Trace Contaminants Found in LP-Gas

ammonia
methanol
water
excessive sulfur
fluorides
metal particles
common dirt
heavy hydrocarbons
plasticizers
excessive ethane, butane ethylene, propylene, etc

Source: Investigation of Portable or Handheld Devices for Detecting Contaminants”, (Hutzler, Johnson 2005)

- In “Investigation of Portable or Handheld Devices for Detecting Contaminants”, (Hutzler, Johnson 2005), found the following:
 - A consensus belief exists among the propane industry that at the point of production or import most propane adheres to an HD-5 specification.
 - LP-Gas contamination occurs at various points in the supply chain most probably in small quantities over an extended period of time.
 - LP-Gas contaminants can include water, oily or waxy residues (from storage caverns, compressors, pipe dopes, gaskets, hoses, heat transfer fluids), ammonia (potentially serious for promoting copper and brass corrosion), and other corrosion agents that include fluorides, chlorides, bromides, hydrogen sulfide, and sulfur.
 - The impact of these propane contaminants and off-specification gas is not well documented.

Research is warranted to investigate the effect of LP-Gas contaminants and off-specification gas on U.S. LPG regulator performance.

Literature Review of Regulator Service Life

Codes & Standards Review

LP-Gas is the primary fuel of choice for heating in 5 percent of all households in the United States. It is through the International Fuel Gas Code, the National Fuel Gas Code (NFPA 54), and the Liquid Petroleum Gas Code (NFPA 58), along with the referenced standard on LP-Gas Regulators (UL 144), ensures that LP-Gas is safe and useable for consumers.

A review of the codes and standards pertinent to LP-Gas regulator safety was important to determine to what extent useful or service life was addressed within their requirements.

UL 144 LP-Gas Regulators is the current performance standard for LP-Gas regulators. Codes and standards that reference UL 144 including NFPA 54: National Fuel Gas Code, NFPA 58: Liquid Petroleum Gas Code and ANSI Z21.18a-2001/CSA 6.3a Gas Appliance Pressure Regulators are silent on useful or service life of LPG system components.

UL 144 LP-Gas Regulators

UL 144 LP-Gas Regulators is a safety standard whose requirements cover the construction, performance, manufacturing and production test, and markings of pressure regulators for use with LPG equipment. UL 144 is referenced by the following standards:

- Liquefied Petroleum Gas Code, (National Fire Codes, Vol. 2) NFPA 58;
- National Fuel Gas Code (IAS/A.G.A. Z223.1), NFPA 54;
- Outdoor Cooking Gas Appliances, IAS/A.G.A. Z21.58; and
- Standard on Recreational Vehicles (RVIAA119.2) (National Fire Codes, Vol. 7), NFPA 501C.

The requirements include tests to verify outlet pressure stability characteristics within the manufacturer's rated capacity.

Standard Requirements

Temperature - Regulators covered by UL 144 must be capable of being used when exposed to ambient temperatures within the range of minus 40°F – plus 130°F (minus 40°C – plus 55°C).

Materials for a part are selected based upon its capability to perform under the conditions to which it is subjected. While test requirements are designed to ensure acceptable long-term performance, no determination of “useful” life is made and such a determination is outside the scope of this consensus standard.

- “A part of a regulator in contact with LP-Gas shall be resistant to the action of the fluid under the service conditions to which it is subjected.”
- Elastomeric materials are to be subjected to the following tests:
 - LP-Gas Compatibility Test (Section 30);

Literature Review of Regulator Service Life

- ASTM D471 Test Method for Rubber Property- Effect of Liquids specifically volume test (Section 31) and weight loss test (Section 32);
- Accelerated-Aging Test (Section 33);
- Low Temperature Test (Section 34).
- Polymeric materials are to be subjected to following tests:
 - LP-Gas Compatibility Test (Section 30),
 - Accelerated-Aging Test (Section 33).
- “When corrosion of a part interferes with the function of the regulator or corrosion results in deterioration, the part shall be of a corrosion-resistant material or be provided with a corrosion-resistant protective coating.”
 - Cadmium and Zinc plating are specified to provide resistance to corrosion.
- The body and bonnet of a regulator must be made of a specified metal; nonmetallic material cannot be used. Specified metals include:
 - Aluminum alloys,
 - Ductile (nodular) iron,
 - Malleable iron,
 - High-strength Grey Iron Class 40B
 - Copper alloys,
 - Steel,
 - Zinc alloys.
- The 10-Day Moist Ammonia-Air Stress Cracking (Section 29) on brass parts containing more than 15 percent zinc.
- Endurance Test to prove performance over specified number of cycles.

Underwriters Laboratories’ UL 144 LP-Gas Regulators is the current performance standard for LP-Gas regulators and is designed for new regulators, not regulators that have been in the field. UL 144 is silent on the issue of service or useful life. Test requirements for materials in UL 144 are found in American Society of Testing and Materials (ASTM) standards that are designed to be an indicator of long-term performance.

NFPA 54: National Fuel Gas Code

NFPA 54: National Fuel Gas Code is an ANSI accredited consensus safety code for gas piping systems on consumers’ premises. NFPA 54 covers the installation of gas utilization equipment and accessories for use with fuel gases such as natural gas, manufactured gas, liquefied petroleum gas in the vapor phase, liquefied petroleum gas-air mixtures, or mixtures of these gases.

Literature Review of Regulator Service Life

NFPA 54 coverage of the gas piping systems includes the design, fabrication, installation, testing, operation, and maintenance of gas piping systems from the point of delivery to the connections with each gas utilization device.

The LP-Gas systems covered by this NFPA 54 are limited to a maximum operating pressure of 20 psig. The code requires that systems operating below -5°F must be designed to either accommodate liquid LP-Gas or prevent LP-Gas vapor from condensing back into liquid.

NFPA 54 coverage of gas utilization equipment includes the installation of gas utilization equipment, related accessories, and their ventilation and venting.

NFPA 54 is silent on useful or service life of LP-Gas system components and references UL 144 with regards to pressure relief valve discharge and over pressure shutoff of LP-Gas regulators.

NFPA 58: Liquefied Petroleum Gas Code

NFPA 58: Liquefied Petroleum Gas Code is an ANSI accredited consensus code that applies to the construction, installation, and operation of fixed and portable liquefied petroleum gas systems in bulk plants and commercial, industrial (with specified exceptions), institutional, and similar properties.

NFPA 58 coverage also includes truck transportation of liquefied petroleum gas; engine fuel systems on motor vehicles and other mobile equipment; storage of containers awaiting use or resale; installation on commercial vehicles; and liquefied petroleum gas service stations.

NFPA 58 is silent on useful or service life of LP-Gas system components and references UL 144 with regards to pressure relief valve discharge and over pressure shutoff of LP-Gas regulators.

ANSI Z21.18a-2001/CSA 6.3a Gas Appliance Pressure Regulators

ANSI Z21.18a-2001/CSA 6.3a Gas Appliance Pressure Regulators is a standard that details test and examination criteria for gas appliance pressure regulators for use with natural, manufactured, and mixed gases, liquefied petroleum gases and LP gas-air mixtures. Such devices, either individual or in combination with other controls, are intended to control selected outlet gas pressures to individual gas appliances.

ANSI Z21.18a-2001/CSA 6.3a is silent on useful or service life of LP-Gas system components and references UL 144 with regards to pressure relief valve discharge and over pressure shutoff of LP-Gas regulators.

The literature review found that codes and standards referencing UL 144 including NFPA 54: National Fuel Gas Code, NFPA 58: Liquid Petroleum Gas Code and ANSI Z21.18a-2001/CSA 6.3a Gas Appliance Pressure Regulators are silent on useful or service life of LPG system components.

Literature Review of Regulator Service Life

US Regulator Manufacturing Literature Review

A review of manufacturers' literature was important to determine if there was scientific or engineering support for a 15-year or greater replacement recommendation, and if an extended service life recommendation for some models was warranted.

A substantial percentage of low-pressure propane/LPG regulators used worldwide are made by U.S. manufacturers. These regulators are constructed to comply with U.S. standards and then separately certified for use in overseas markets. For this reason, GTI focused its review of manufacturer's literature to U.S. manufacturers. Specifically, GTI focused on three companies that together have a predominant share of the U.S. LP-Gas regulator market: Fisher, RegO[®], and Sherwood.

RegO[®] recommends regulator service life of 25 yrs for regulators (except single-stage) manufactured after 1995; all other regulators have a service life of 15 years. Fisher recommends regulator replacement at 20 years, or over 15 years of age for regulators that have experienced conditions (corrosion, underground systems, flooding, etc.) that would shorten their service life. In email correspondence, Sherwood reported a recommended 25 year service life on many regulator models. However, a review of their literature to date found recommended service life of 15 years.¹

Typical materials used in LPG regulators that were identified the literature include zinc or die cast aluminum bodies, chromate coatings, synthetic rubbers such as nitrile, and stainless steel springs.

Service life attributes, or manufacturers' stated features that influence service life include corrosion resistance coatings and relief valve seat (Fisher); Stainless steel relief valve spring and retainer (Fisher); and painted, heavy-duty zinc (RegO[®]).

All three manufacturer's literature reference National Propane Gas Association (NPGA) documents in discussions related to installation, inspection, maintenance, and safety. NPGA no longer supports these documents and has released these documents to the public domain provided that the NPGA is not attributed to these documents.

Discontinued documents that are referenced include:

- NPGA Installation and Service Guide Book #4003,
- NPGA Propane Safety and Technical Support Manual Bulletin T403,
- NPGA Safety Pamphlet 306 "LP-Gas Regulator and Valve Inspection and Maintenance",
- NPGA LPG Safety Handbook #0001, and
- NPGA Bulletin #133-80.

These documents can no longer be referenced as NPGA documents and effort should be made by the manufacturers to acknowledge and correct this within their product literature.

¹ Email correspondence with Jim Rockwood, Sherwood Harsco Corporation on November 02, 2005.

Literature Review of Regulator Service Life

Fisher Regulators

Fisher Regulators, a division of Emerson Process Management, serves the pressure regulator needs of process industries and natural gas utilities worldwide. Fisher Regulators offer pressure and flow control solutions in two broad product categories industrial and natural gas.

Products

Table 3 Fisher LP-Gas Regulators

	Outlet Pressure Range	Service	Recommended Replacement Life
First Stage Regulators			
3-hundred series	10 psig (Non-adjustable)	Up to 900,000 Btu/hr (approx. 360 SCFH LP)	15 yrs
6-hundred series	Adjustable (4-6 psig or 8-12 psig model dependent)	Up to 2.4 MM Btu/hr (approx. 960 SCFH LP)	20 yrs
Second-Stage Regulators			
3-hundred series ▪ Compact design	9-13" WC (factory set at 11" WC)	Up to 270,000 Btu/hr	15 yrs
6-hundred series ▪ High capacity internal relief valve	9-13" WC (factory set at 11" WC) or 13-20" WC (factory set at 18"WC) model dependent	Up to 1.4 MM Btu/hr	20 yrs ▪ Double Failure Protection
HSRL series ▪ High strength cast iron body ▪ High capacity internal relief valve	9-13" WC (factory set at 11" WC)	Up to 2.1 MM Btu/hr	
Integral Two-Stage Regulators			
3-hundred series ▪ Compact design	9-13" WC (factory set at 11" WC)	Up to 275,000 Btu/hr	15 yrs
6-hundred series	9(or 9.5 depending	Up to 750,000 Btu/hr	20 yrs

Literature Review of Regulator Service Life

	Outlet Pressure Range	Service	Recommended Replacement Life
<ul style="list-style-type: none"> ▪ High capacity internal relief valve 	on model)-13" WC (factory set at 11" WC)		<ul style="list-style-type: none"> ▪ Double Failure Protection

Materials²

“The R600 series use aluminum die cast casings which are chromate coated prior to painting. Fisher paints the parts prior to assembly. Relief valve springs are stainless steel. Main springs are carbon steel plated. Rubber materials are typically a nitrile or other special blend of synthetic rubber. Engineered designs are used for the pusher post/relief valve seat, adjusting screw and vent flapper parts. These are typically glass filled for added strength and moisture stability.”

“R300 series are built much the same except that the lower casing is zinc so that the flange areas can be crimped.”

“The new compact regulator uses much of the same material technology and as the R600 series. The coating and painting process is the same as the R600 series.”

Installation Considerations

The installation considerations shown below are from the Fisher regulator manuals. The manuals provide general safety precautions and can be categorized in terms of: 1) initial considerations, 2) proper venting, and 3) preventing in-service damage.

Initial Considerations

- Before installing the regulator, check for damage that might have occurred in shipment. Also check for and remove any dirt or foreign material that may have accumulated in the regulator body or the pipeline.
- Apply pipe compound to the male threads of the pipe -- caution has to be exercised as to not introduce pipe compound (foreign matter) in the regulator body.
- Make sure gas flow through the regulator is in the same direction as the arrow on the body “Inlet” and “Outlet” connections that are clearly marked.

² Email correspondence with Jim Griffin May 25th 2005.

Literature Review of Regulator Service Life

Venting

- LP-gas may discharge to the atmosphere through the vent. An obstructed vent which limits air or gas flow can cause abnormally high pressure. Failure to use a vent line on indoor installations can cause a hazardous accumulation of gas.
- Install the regulator so that any gas discharge through the vent or vent assembly is over 3-feet horizontally from any building opening below the level of discharge.
- Horizontally mounted regulators, such as those found in single cylinder installations, must be installed beneath a protective cover. If possible, slope or turn the vent down sufficiently to allow any condensation to drain out of the spring case.
- By code, regulators installed indoors have limited inlet pressure, and they require a vent line to the outside of the building.

Preventing In-Service Damage

- Protect the vent against the entrance of rain, snow, ice formation, paint, mud, insects, or any other foreign material that could plug the vent or vent line. According to a discussion with Jim Griffin of Fisher, the most predominant cause of pre-mature regulator failure is due to debris deposit inside the regulator.
- A regulator installed outdoors without a protective hood must have its vent pointed vertically down to allow condensate to drain. This minimizes the possibility of freezing and of water or other foreign material entering the vent and interfering with proper operation.

Maintenance Considerations

Due to normal wear or damage that may occur from external sources, these regulators must be inspected and maintained periodically. The frequency of inspection and replacement of the regulators depends upon the severity of service conditions or the requirements of local, state, and federal regulations. Visually inspect the regulator each time a gas delivery is made for:

- Improper installation.
- Plugged or frozen vent.
- Wrong regulator or no regulator in the system.
- Internal or external corrosion.
- Age of the regulator.
- Any other condition that could cause the uncontrolled escape of gas.

Warranty

5 year limited warranty.

Literature Review of Regulator Service Life

Fisher Literature Results

Table 4 Fisher Propane Regulator Service/Safety Bulletins

Fisher Reference Number	Title	Comments
LP-7	Product Specific Literature R-622H	<ul style="list-style-type: none"> ▪ Service Life: 20 year Recommended replacement life <ul style="list-style-type: none"> - It is recommended to replace regulators that are over 15 years of age or that have experienced conditions (corrosion, underground systems, flooding, etc.) that would shorten their service life. (page 39) ▪ Life Attribution <ul style="list-style-type: none"> - Corrosion resistance coatings and relief valve seat - Stainless steel relief valve spring and retainer ▪ References <ul style="list-style-type: none"> - NFPA 54, "National Fuel Gas Code" <ul style="list-style-type: none"> ▪ Pipe and tubing sizing (page 18, 23-28) - NFPA 58, "Liquid Petroleum Gas Code " <ul style="list-style-type: none"> ▪ Container location and installation (page 11)
LP-10	LP-Gas Serviceman's Handbook	<ul style="list-style-type: none"> ▪ Service Life: <ul style="list-style-type: none"> - It is recommended to replace regulators that are over 15 years of age or that have experienced conditions (corrosion, underground systems, flooding, etc.) that would shorten their service life. (page 39) ▪ References: <ul style="list-style-type: none"> - NFPA 54, "National Fuel Gas Code" <ul style="list-style-type: none"> ▪ Pipe and tubing sizing (page 18, 23-28)

Literature Review of Regulator Service Life

		<ul style="list-style-type: none"> - NFPA 58, "Liquid Petroleum Gas Code" <ul style="list-style-type: none"> ▪ Container location and installation (page 11) ▪ Pipe and tubing sizing (page 18) ▪ Regulator Installation (page 34) - Fisher Bulletins LP-18 and LP-24 <ul style="list-style-type: none"> ▪ Regulator Freezeups (page 32) - UL 144 and Fisher Bulletin LP-15 <ul style="list-style-type: none"> ▪ Regulator Installation, operation and maintenance (page 33) - Fisher Bulletin LP-32 <ul style="list-style-type: none"> ▪ Regulator Inspection (page 39) - NPGA Safety Bulletin 306 [Discontinued] <ul style="list-style-type: none"> ▪ Troubleshooting domestic tank fittings (page 40)
LP-12	Regulator Selection And Pipe Sizing Chart	<ul style="list-style-type: none"> ▪ Handy reference guide for selecting Fisher regulators with convenient method of sizing pipe on the reverse side.
LP-15	Give A Regulator the Attention it Deserves	<ul style="list-style-type: none"> ▪ Explains how domestic self-operated regulators work; gives installation and maintenance tips. <ul style="list-style-type: none"> - Issues <ul style="list-style-type: none"> ▪ Freeze Up prevention ▪ Chips ▪ Vapor fall out ▪ Service Life: Not addressed ▪ References: <ul style="list-style-type: none"> - NFPA 54, "National Fuel Gas Code" <ul style="list-style-type: none"> ▪ PRV discussion (p1) ▪ Installations as per (p2) - NFPA 58, "Liquid Petroleum Gas Code"

Literature Review of Regulator Service Life

		<ul style="list-style-type: none"> ▪ PRV discussion (p1) ▪ Installations as per (p2)
LP-18	How Drip-Lips Can Prevent Regulator Freeze-Ups	<ul style="list-style-type: none"> ▪ Shows how drip lip style vents can reduce the possibility of vent blockage due to freezing rain.
LP-19	How to Keep Your Internal Valves Working	A discussion about the operation, installation and maintenance of Fisher's C-Series Internal Valves.
LP-24	Plain Facts about freezing Regulators	Describes how a regulator can freeze internally and gives tips to prevent this situation.
LP-29	Complying with NFPA 58 Transfer Area Rulings	An overview of the NFPA requirements with examples of acceptable equipment
LP-31	Inspecting LP-Gas Regulators. What to Look For	Discusses service life, reducing vent blockage, corrosion, inspection, etc.
LP-32	Inspecting LP-Gas Regulators. What to Look For	Discusses service life, reducing vent blockage, corrosion, inspection, etc.

Literature Review of Regulator Service Life

RegO[®] Regulators

RegO[®] Valves and Regulators are sold by a network of distributors and agents throughout the United States, Canada, and over 100 countries around the globe.

Products

Table 5 RegO[®] LP-Gas Regulators

	Outlet Pressure Range	Service	Recommended Replacement Life
First Stage Regulators			
LV3303TR series <ul style="list-style-type: none"> ▪ Compact design 	10 psig (Non-adjustable)	Up to 1.5 MM Btu/hr	25 yrs (Post 1995 Only)
LV4403SR/TR series <ul style="list-style-type: none"> ▪ Built-in pressure gauge 	Adjustable (1-5 or factory set at either 5-10 psig - model dependent)	Up to 2.5 MM Btu/hr	25 yrs (Post 1995 Only)
Second-Stage Regulators			
LV4-thousand series <ul style="list-style-type: none"> ▪ Incorporate integral relief valve 	9-13" WC (or 2 psig@10 psig inlet depending on model).	Up to 1 MM Btu/hr	25 yrs (Post 1995 Only)
LV5-thousand series <ul style="list-style-type: none"> ▪ Incorporate integral relief valve 	9-13" WC (factory set at 11" WC) or 13-20" WC (factory set at 18"WC) - model dependent	Up to 2.2 MM Btu/hr	25 yrs (Post 1995 Only)
Twin Stage Regulators			
LV404B4/LV404B9 Series <ul style="list-style-type: none"> ▪ Relief vent on the first stage is consistently in the down position 	9-13" WC (factory set at 11" WC)	Up to 525,000 Btu/hr	25 yrs (Post 1995 Only)
LV404B23/LV404B29 Series <ul style="list-style-type: none"> ▪ May be used with a variety of pigtails, inlet adapters and manifolds 	9-13" WC (factory set at 11" WC)	Up to 200,000 Btu/hr	25 yrs (Post 1995 Only)

Literature Review of Regulator Service Life

Materials

Tables 6 and 7 below summarize the construction materials that RegO[®] uses for its low-pressure propane/LP-Gas regulators.

Table 6 Component Materials by RegO[®] Regulator Series

	LV3303TR Series	LV4403SR and TR Series	LV4403B Series	LV4403B66RA Series	LV4403Y Series
Body	Zinc	Die Cast Zinc	Die Cast Zinc	Die Cast Aluminum	Die Cast Zinc
Bonnet	Zinc	Die Cast Zinc	Die Cast Zinc	Die Cast Zinc	Die Cast Zinc
Nozzle Orifice		Brass	Brass	Brass	Brass
Spring	Steel	Steel	Steel	Steel	Steel
Valve Seat Disc	Resilient Rubber	Resilient Rubber	Resilient Rubber	Resilient Rubber	Resilient Rubber
Diaphragm	Integrated Fabric and Synthetic Rubber	Integrated Fabric and Synthetic Rubber	Integrated Fabric and Synthetic Rubber	Integrated Fabric and Synthetic Rubber	Integrated Fabric and Synthetic Rubber

Table 7 Component Materials by RegO[®] Regulator Series

	LV5503Y Series	LV5503B Series	LV404B4 and LV404B9 Series	LV404B23 Series	LV404B29 Series
Body	Die Cast Aluminum	Die Cast Aluminum	1 st Stage – Brass 2 nd Stage – Die Cast Zinc	1 st Stage – Die Cast Zinc 2 nd Stage – Die Cast Zinc	1 st Stage – Die Cast Zinc 2 nd Stage – Die Cast Zinc
Bonnet	Die Cast Aluminum	Die Cast Aluminum	Die Cast Zinc	1 st Stage – Die Cast Zinc 2 nd Stage – Die Cast Zinc	1 st Stage - Brass 2 nd Stage – Die Cast Zinc
Nozzle Orifice	Brass	Brass			
Spring	Steel	Steel	Steel	Steel	Steel
Valve Seat Disc	Resilient Rubber	Resilient Rubber		Resilient Rubber	Resilient Rubber
Diaphragm	Integrated Fabric and Synthetic Rubber	Integrated Fabric and Synthetic Rubber	Integrated Fabric and Synthetic Rubber	Integrated Fabric and Synthetic Rubber	Integrated Fabric and Synthetic Rubber

Installation Considerations

The installation considerations shown below are from the RegO[®] regulator manuals. The manuals provide general safety precautions and can be categorized in terms of: 1) proper venting 2) conformance to code, and 3) leak testing.

Literature Review of Regulator Service Life

General Safety Precautions

- Regulators should be installed with the vent facing down or protected so their operation will not be affected by the elements.
- The vents and/or discharge tubes must be protected from the elements and must be equipped with a screen to prevent bugs from obstructing the opening.
- It should not be necessary to remind readers that regulators must be installed in strict conformance with NFPA Pamphlets 54 and 58, and all other applicable codes and regulations.
- Always test for leaks at time of installation and inspect for leaks if there is reason to believe that pipe connections could cause a hazard.

Maintenance Requirements

Regulator inspection for corrosion should be made according to the guidelines listed below:

- For underground installations subject to submersion, the regulator should be inspected every time the container is filled.
- For known corrosive atmospheres of salt air or chemical pollution, the regulator should be inspected at least once a year.
- For other applications, the regulator should be inspected every 3 years.
- A casual inspection for corrosion can be made by examining the surface and looking into the bonnet after the bonnet cap has been removed. This sometimes will alert the inspector to corrosive conditions.
- If any corrosion is evident, replace the regulator.

Warranty

LIMITED WARRANTY

Engineered Controls International, Inc warrants its regulators and repair kits that it manufactures and sells to be free from manufacturing defects only for a period of 12 months from installation or 18 months from the factory shipping date, whichever is earlier. Engineered Controls International, Inc will repair, replace or refund defective material if notified by the buyer within 30 days of discovery but not without obtaining written consent.

Defective items due to misuse, alteration or neglect are not covered in the warranty. Engineered Controls International, Inc is not to be held liable for any loss, cost of repair, or damages of any kind connected with the use, sale or repair of any of their products. This warranty applies only to products installed and used according to Engineered Controls International, Inc.'s printed instructions.

Literature Review of Regulator Service Life

RegO® Literature Results

Table 8 RegO® Propane Regulator Service/Safety Literature Search Results

Item	Title	Comment on Service Life
L-545	LP-Gas Serviceman's Manual	<ul style="list-style-type: none"> ▪ References: <ul style="list-style-type: none"> - NFPA 54, "National Fuel Gas Code" <ul style="list-style-type: none"> ▪ Pipe Sizing Table (p20-22), ▪ Indoor regulator restriction (p30) ▪ Section on Inspection, Testing and Purging (p34), ▪ Leak test (p37), - NFPA 58, "Liquefied Petroleum Gas Code" <ul style="list-style-type: none"> ▪ Cylinder placement (p12-14) ▪ Pipe Sizing Table (p20)-22, ▪ Single Stage Regulator restrictions (p26), ▪ Venting (p29), ▪ Indoor regulator restriction (p30) - NPGA Propane Safety and Technical Support Manual Bulletin T403 – Purging (p37), [Discontinued] - RegO® Products Safety Warning WB-3 Excess flow valves (p38) - RegO® Products Safety Warning WB-6 Pressure Relief Valve (p40)
L-500	LP-Gas & Anhydrous Ammonia Equipment	<ul style="list-style-type: none"> ▪ Service Life <ul style="list-style-type: none"> - When all of these recommendations are followed, the recommended service life of an ECII/RegO® regulator (except single stage) manufactured after 1995 is 25 years (A5).

Literature Review of Regulator Service Life

Item	Title	Comment on Service Life
		<ul style="list-style-type: none"> - The recommended service life of all other ECII/RegO[®] regulators is 15 years (A5). ▪ Warning: <ul style="list-style-type: none"> - All ECII[®] products are mechanical devices that will eventually become inoperative due to wear, corrosion and aging of components made of materials such as rubber. The environment and conditions of use will determine the safe service life of these products. Inspection and maintenance on a periodic basis is essential (A3). - Life of a regulator is determined by the environment in which it “lives.” (A2, A7) ▪ Recommendations <ul style="list-style-type: none"> - Notice Periodic installation and maintenance should be performed only by qualified personnel (A3). - Filter The use of an in-line filter should be considered when other system components may be unclean and the system contaminated by rust, scale, dirt, debris or other foreign material (A3). ▪ Causes of Failure <ul style="list-style-type: none"> - High Pressure (A5-6), - Leaks (A6), - Loss of Pressure (A7). ▪ Responsibility Statement (A7) NOTE: There is a developing trend in state legislation and in proposed national legislation to make the owners of products responsible for replacing products before they reach the end of their safe useful life. LP-Gas dealers should be aware of legislation which could affect them.

Literature Review of Regulator Service Life

Item	Title	Comment on Service Life
		<ul style="list-style-type: none"> ▪ References: <ul style="list-style-type: none"> - NPGA Safety Pamphlet 306 "LP-Gas Regulator and Valve Inspection and Maintenance." (A5), [Discontinued] - NFPA 54, "National Fuel Gas Code" (A5), - NFPA 58, "Liquefied Petroleum Gas Code" (A5), ▪ Life Attribution (A13) Painted, heavy-duty zinc (body and bonnet) resists corrosion and gives long-life protection, even under "salty air" conditions. (LV4403)
L-	RegO [®] Determination Guide	<ul style="list-style-type: none"> ▪ Guide for determining age and type of regulators; identification of regulators "beyond their safe service life" .

Literature Review of Regulator Service Life

Sherwood Regulators

Sherwood, a division of Harsco, is an ISO 9001 certified manufacturer of LP-Gas regulators and other propane and natural gas equipment. In 1996, Sherwood merged with the Taylor-Wharton Gas Equipment division of Harsco. Sherwood LP gas regulators occupy the third place in the market place trailing Fisher and Rego®; however Sherwood has a more diversified line of regulators for the compressed gas industry including industrial, chlorine, medical, welding, specialty, semiconductor, life support and LP-Gas.

Products

Table 9 Sherwood LP-Gas Regulators

	Outlet Pressure Range	Service	Recommended Replacement Life
First Stage Regulators			
	Adjustable (5-15 psig (Factory set at 10 psig)	Up to 1.1 MM Btu/hr	15 yrs
Second-Stage Regulators			
<ul style="list-style-type: none"> ▪ straight-through design ▪ right angle design 	9-13" WC (Factory set at 11" WC)	Up to 800,000 Btu/hr	15 yrs
Integral Two-Stage Regulators			
920 Series <ul style="list-style-type: none"> ▪ Bonnet vent position above outlet or 90° to outlet design 	9-13" WC or 13-18" depending on model (Factory set at 11" WC or 15" WC depending on model)	Up to 550,000 Btu/hr	15 yrs
921 Series <ul style="list-style-type: none"> ▪ Bonnet vent position above outlet or 90° to outlet 	9-13" WC or 13-18" depending on model (Factory set at 11" WC or 15" WC depending on model)	Up to 550,000 Btu/hr	15 yrs

Materials

Regulator features include Heavy zinc die casting to eliminate porosity. Materials used in Sherwood LP gas regulators could not be determined through available literature.

Literature Review of Regulator Service Life

Installation Considerations

The installation considerations given in the Sherwood regulator manuals are general safety precautions.

Safety Precautions

- Make sure the lines to the regulator are free of all foreign matter. Blow out all the lines prior to installing the regulator. If foreign matter should become embedded in the regulator seat, it could cause high lockup pressure. The rising pressure could activate the pressure relief device inside the regulator.
- Consider using in-line filters to help prevent contaminants from entering the regulator.
- To protect the regulator from ice, snow and sleet, mount the regulator under a hood or covering. Make sure the vent is pointing downward. This allows moisture collected above the diaphragm to drain out through the vent.
- Undersized piping reduces delivery pressure because of increased friction. The regulator must never be adjusted for higher outlet pressures to compensate for undersized lines. This could result in high lockups, fluctuating pressures, and inefficient combustion.

Maintenance Requirements

In email correspondence, Sherwood reported a recommended 25 year service life on many regulator models. However, a review of their literature to date found recommended service life of 15 years.³

Sherwood regulators must be routinely inspected according to industry standards, and replaced after a **maximum of fifteen (15) years** of use. Regulators that are exposed to extreme heat, cold or other severe environmental conditions must be inspected and replaced more often. Check the regulator frequently to make sure the vent is not plugged by mud, ice, insects or any other foreign matter. Vents must be clear and fully open at all times to ensure proper operation.

Warranty

Sherwood warrants its regulators that it manufactures and sells to be free from manufacturing defects only for a period of **three years** from date of shipment. Sherwood will repair or replace defective material at its factory but not without obtaining written consent. Defective items due to misuse, alteration or neglect are not covered in the warranty; nor are Sherwood to be held liable for any loss, cost of repair, or damages of any kind connected with the use, sale or repair of any of our products. This warranty applies when products are installed and used in accordance with NFPA and ANSI

³ Email correspondence with Jim Rockwood, Sherwood Harsco Corporation on November 02, 2005.

Literature Review of Regulator Service Life

acceptable standards. No claims are made as to the ability of a particular product to be used in conjunction with products of other manufacturers.

Literature Review of Regulator Service Life

Sherwood Literature Results

Table 10 Sherwood Propane Regulator Service/Safety Bulletins

Sherwood Reference Number	Title	Comments
LPG-003-99	Sherwood LPG Products	<ul style="list-style-type: none"> ▪ Regulators (LPG Products Section) <ul style="list-style-type: none"> - Meet UL Standard 144 and NFPA Pamphlet #58. (p 3.1) - Warranty: All Sherwood regulators are covered by a three-year limited replacement warranty (p 3.1) ▪ Service Life (p1) : <ul style="list-style-type: none"> - Recommends replacement after (15) years of use. - Severe environmental conditions warrant inspection and replacement more often. - Consult the National Propane Gas Association (NPGA) for inspection and replacement information ▪ Other References <ul style="list-style-type: none"> - NFPA 54, "National Fuel Gas Code" <ul style="list-style-type: none"> ▪ Qualified individuals must have a working knowledge of... (p2.1) - NFPA 58, "Liquefied Petroleum Gas Code" <ul style="list-style-type: none"> ▪ Freeze-up prevention (p3) ▪ As per 1995 edition ... two stage regulators are now mandatory in the United States. (p2) ▪ Piping charts (p2.1) ▪ Qualified individuals must have a working knowledge of... (p2.1)

Literature Review of Regulator Service Life

		<ul style="list-style-type: none"> - NPGA LPG Safety Handbook #0001, [Discontinued] <ul style="list-style-type: none"> ▪ Freeze-up prevention - Products Section (p3) - NPGA Bulletin #133-80[Discontinued] <ul style="list-style-type: none"> ▪ Freeze-up prevention - Products Section (p3) ▪ Instruction Sheets Section <ul style="list-style-type: none"> - Notice: All Sherwood products must be used in strict compliance with <ul style="list-style-type: none"> ▪ NFPA 54, "National Fuel Gas Code" ▪ NFPA 58, "Liquefied Petroleum Gas Code" - Additional Reference: <ul style="list-style-type: none"> ▪ NPGA Installation and Service Guide Book #4003. [Discontinued] ▪ Pressure Relief Valves (PRVs) <ul style="list-style-type: none"> - Sherwood recommends PRVs be replaced after ten (10) years of use. - Maintenance procedures Reference <ul style="list-style-type: none"> ▪ CGA Pamphlet S-1.1, Pressure Relief Device Standards -Cylinders, Section 9.1. ▪ NPGA Pamphlet #306, LPG Regulator and Valve Inspection and Maintenance[Discontinued] ▪ NFPA Pamphlet #58, Storage and Handling of Liquefied Petroleum Gases. ▪ NFPA Pamphlet #59, LP Gases at Utility Gas Plants ▪ Safety Guidelines References. <ul style="list-style-type: none"> - NFPA 54, "National Fuel Gas Code" - NFPA 58, "Liquefied Petroleum Gas Code" - National Propane Gas Association
--	--	---

Literature Review of Regulator Service Life

		<ul style="list-style-type: none"> ▪ Technicians Guide Section References <ul style="list-style-type: none"> - NFPA 54, "National Fuel Gas Code" <ul style="list-style-type: none"> ▪ General Safety (p1) - NFPA 58, "Liquefied Petroleum Gas Code" <ul style="list-style-type: none"> ▪ General Safety (p1) - NPGA LPG Safety Handbook #0001, [Discontinued] <ul style="list-style-type: none"> ▪ General Safety (p1)
LPO3B98	Sherwood Technician's Guide to LPG	<ul style="list-style-type: none"> ▪ Service Life (p45) : <ul style="list-style-type: none"> - Recommends replacement after (15) years of use.

Literature Review of Regulator Service Life

Conclusions

The literature review was not able to document scientific or engineering support for a service-life recommendation of 15-years or greater. The findings of the literature review warrant further research in the use and variability of plasticizers and extenders in the rubber composition of LPG regulator components; the long-term effect a propane operating environment has on elastomer and spring performance; and the effect of LP-Gas contaminants and off-specification gas on U.S. LPG regulator performance.

References

1. American Gas Association and National Fire Protection Association, National Fuel Gas Code, NFPA 54/ANSI Z223.1, September, 2002.
2. Battelle, “An Assessment of the Merit of Conditioning LP Gas Hoses Volume I & II”, 2005.
3. C. Grethlein, B. D. Craig, R. A. Lane, “ELASTOMERIC SEALS 101 – A BRIEF TUTORIAL”, The AMPTIAC Quarterly, Volume 8, Number 2, pp11-19.
4. D. L. Hertz, Jr., H. Bussem, and T. W. Ray, "Nitrile Rubber - Past, Present & Future" Presented at a meeting of the Rubber Division, American Chemical Society Pittsburgh, Pennsylvania, October 11-14, 1994.
5. ENVIRON International Corporation, “Investigation of the Causes of Leaks in Natural Gas Pipeline Compression Couplings”, July 2005.
6. Fisher Product Literature, LP-7: Product Specific Literature; LP-10: LP-Gas Serviceman’s Handbook; LP-12: Regulator Selection And Pipe Sizing Chart Give A Regulator the Attention it Deserves; LP-15: How Drip-Lips Can Prevent Regulator Freeze-Ups; LP-18: How to Keep Your Internal Valves Working; LP-19: Plain Facts about freezing Regulators; LP-24: Complying with NFPA 58; LP-29: Transfer Area Rulings; LP-31: Inspecting LP-Gas Regulators. What to Look For; LP-32: Inspecting LP-Gas Regulators. What to Look For.
7. Gas Processors Suppliers Association, Engineering Data Book, Vol I, Sec 2 Product Specification, 2004.
8. Hutzler, Johnson, “Investigation of Portable or Handheld Devices for Detecting Contaminants”, 2005,
9. Jeong-Rock Kwon, Young-Gyu Kim Gas Safety R&D Center, Korea Gas Safety Corporation, “Aging Characteristics of Low Pressure LPG Regulators for Domestic Use”, May 1999.
10. Jeong-Rock Kwon, pGas Safety R&D Center, Korea Gas Safety Corporation, “Extraction Properties in LPG High Pressure Rubber Hoses”, 2003.
11. Jeong-Rock Kwon, Gas Safety R&D Center, Korea Gas Safety Corporation, “The Effects of LPG Trace on Rubber Properties”, May 1999.
12. Mark Adams, James L. Gossett, “Sulfide Stress Cracking and the Commercial Application of NACE MR0175-84” 1974, Updated 1984.
13. National Fire Protection Association, Liquid Petroleum Gas Code, NFPA 58, January, 2004.
14. National Fire Protection Association, Code Development Process, www.nfpa.org.

15. National Propane Gas Association, "Copyright Waiver on Old Bulletins", email correspondence with Bruce Swiecicki on May 4, 2005.
16. Ohm, Robert F., "The Vanderbilt Rubber Handbook -13th Edition", R.T. Vanderbilt Company, Inc., 1990.
17. RegO® Product Literature, L-545: LP-Gas Serviceman's Manual; L-500: LP-Gas & Anhydrous Ammonia Equipment; and RegO® Determination Guide.
18. Rosato, Dominick V., "Rosato's Plastics Encyclopedia and Dictionary", Oxford University Press, 1993.
19. Sherwood Product Literature, LPG-003-99: Sherwood LPG Products; LPO3B98: Sherwood Technician's Guide to LPG.
20. Underwriters Laboratories Inc, LP-Gas Regulators, UL 144-1999, and revisions up to January, 2002.
21. Underwriters Laboratories Inc., "Method of Development and Maintenance of UL Standards for Safety", 2004.
22. Gas Technology Institute, GRI-01/0169 "Gas Model Energy Code Support", August 2001.

APPENDIX B

Comments Received on the Test Protocol and Battelle's Response

Comments on regulator test protocol and associated justification for the revised protocol

Date	Comment Format	Commenter	Comment Related to...	Comment	Response (Leading to the final test protocol – Attachment 3)
Comments based on regulator test protocol internally distributed on 11/4/2004 (Attachment 1)					
11/12/2004	email	David Kalensky	Type I Relief Capacity Test	<ul style="list-style-type: none"> Perform an additional relief flow at 3 psig. 	<ul style="list-style-type: none"> Initial thoughts were to just test at the high end (5 psig) to ensure conservatism yet still achieve the desired results.
11/12/2004	email	David Kalensky	Endurance Test	<ul style="list-style-type: none"> Prior to the endurance test, regulators should be adjusted to capture drift over time Possibly include in the test regulators that have never been in the field: 1, 5, 10, and 15 years old. 	<ul style="list-style-type: none"> After some thought, it was decided that the endurance test would not provide any useful safety performance information since we do not know enough information about the service conditions under which each regulator operated (how many cycles have already been seen by the regulator?). Therefore, it was decided to remove this test from the regulator testing protocol.
Comments based on regulator test protocol internally distributed on 11/24/2004 and externally distributed on 12/08/2004 (Attachment 2)					
12/09/2004	email	Jim Petersen	2-stage Regulators	<ul style="list-style-type: none"> Will certainly be part of the population; test per the single stage criteria but in a separate category. 	<ul style="list-style-type: none"> Agree Left out solely due to space limitations on the flow chart
03/20/2005	Email	Jeff Borton	2-stage/Regulators	<ul style="list-style-type: none"> The test protocol does not include integral two-stage regulators or automatic changeover regulators – why have these been left out? 	
12/09/2004	email	Jim Petersen	Flow Tests	<ul style="list-style-type: none"> 80 & 200 cfm air flow rate is OK (questioned if using a mass flowmeter or regulator with fixed orifice) Regulator should be tested in the horizontal position for uniformity Record pressure after it has stabilized and note pressure swings (cycling) or noise (humming) – pressure cycling in excess of that stated in UL 144 22.1.1 shall be cause for rejection Do NOT use internal pressure taps on regulator Monitor vent for any discharge – any flow through vent during flow tests should be cause for rejection Run an extra flowrate at 1 cfm to mimic pilot light flow We have to be careful of the two flows picked (80 cfm & 200 cfm) – small, 2nd stage regulators may only be rated to 100 or 150 scfh; should verify manufacturer's rated capacities. 	<ul style="list-style-type: none"> We will be using a flow meter to measure the flow rates. The flow rate will be limited to a max of 80 cfm (200,000 BTU/hr) for all regulators – this represents a typical high flow rate for residential systems. The outlet pressure at a flow rate of 0.5 cfm will be recorded to represent pilot light flows We will record evidence of humming/chattering or outlet pressure instability (press. fluct. > 0.5" WC per UL 144 22.1.1) The regulator vent will be monitored for discharge during the Lock-up/Flow tests – any discharge will be documented Internal pressure taps will NOT be used For 1st stage and single stage regulators tests will start at 100 psig, then 25 psig, then 250 psig – representing a typical press., low press., and high press. sequence. Additionally, the first test at 100 psig will start at a typical residential flow of 30 cfm (75,000 BTU/hr) to adjust the regulator; subsequent tests will start at 80 cfm 10 psig, then 5 psig, then 15 psig. Additionally, the first test at 10 psig will start at a typical residential flow of 30 cfm (75,000 BTU/hr) to adjust the regulator; subsequent
12/15/2004	email	Jim Griffin	Flow Tests	<ul style="list-style-type: none"> Start with mid-inlet pressure; followed by low inlet pressure; followed by max inlet pressure Each sample will have flow curves generated 	
12/16/2004	Email	Ron Czischke	Flow Tests		

Comments on regulator test protocol and associated justification for the revised protocol

Date	Comment Format	Commenter	Comment Related to...	Comment	Response (Leading to the final test protocol – Attachment 3)
12/16/2004	Email	Ron Czischke	Information Tags	<ul style="list-style-type: none"> Information on what type of system the regulator came from should be recorded 	<ul style="list-style-type: none"> Many of the comments came after most of the information tags had been sent out. We feel that the information tags were sufficient to gather the necessary information about each regulator. Unfortunately, many of the tags we have received back are not completely filled in. We wanted to plug or tape over the ports to minimize any odor release during shipment.
12/16/2004	Email & Fax	Sam McTier	Information Tags	<ul style="list-style-type: none"> Add "integral two stage, automatic changeover, and high pressure" under "Indicate Regulator Type" Under "year installed" substitute "Month/Year" for "Date" and delete "(must be within past month)" Under "shipping instructions" there is not a good reason for plugging and taping over regulator ports or putting the regulators in more than 1 zip-lock bag. 	<ul style="list-style-type: none"> Based on many of the comments received, we have decided to eliminate the leakage test as described in the 12/08/2004 test protocol. Instead, we have decided to check for leaks during the Lock-up Test by blocking in the regulator during the initial lock-up test at 100 psig for 1st and single stage and 10 psig for 2nd stage. As stated by Jim Petersen, Jim Griffin, and David Stainbrook this test is more representative of regulator performance rather than regulator design which the original leakage test protocol addressed.
12/09/2004	email	Jim Petersen	Leakage Test	<ul style="list-style-type: none"> Leak test should be the final test since it utilizes the highest pressures Consider adding a pressure decay (low pressure leak) test after the lockup test by shutting off the upstream pressure source 	
12/15/2004	email	Jim Griffin	Leakage Test	<ul style="list-style-type: none"> Not a fan of the UL 144 leakage test for what we are trying to do – the UL test is used to validate joint seal and casing integrity. To perform the test you must defeat the safety mechanisms in the regulator. When you block a vent you will most likely get leakage out of the closing cap of all regulators at the pressures suggested. A more accurate test is to look for external leakage at lock-up; or to be more severe at ~90% of the relief valve reseal pressure. This is more typical of what a regulator experiences day to day and still validates the pressure integrity of the casings without the undue stresses. 	
12/16/2004	Email	David Stainbrook	Leakage Test	<ul style="list-style-type: none"> No reason to block the PRD to test integrity of the atmospheric side of bonnet. This is a design test not a performance test; should be interested in performance not design as qualified by UL. Recommends a leakage test to be conducted at a pressure just under the allowed minimum PRD setting per UL 144 (ex. 1st & single stage could be tested at 18"WC back pressure) 	
12/16/2004	Email	Ron Czischke	Leakage Test	<ul style="list-style-type: none"> Realizes that the regulator should have the relief valve blocked per UL 144 18.3 however in some cases the manufacturer does not give them such a sample – in those cases the vent opening is plugged, and under this condition, any leakage at the bonnet cap is disregarded. 	
03/20/2005	Email	Jeff Borton	Leakage Test	<ul style="list-style-type: none"> Leakage test should be performed at the lock-up pressure. The proposed method does not correctly test the diaphragm or PRD for leakage and exposes the regulator bonnet and cap to pressures, which do not occur in UL tests or actual use. 	
12/16/2004	Email &	Sam McTier	Leakage Test	<ul style="list-style-type: none"> Seal the bonnet cap with a seal washer and pressurize 	

Comments on regulator test protocol and associated justification for the revised protocol

Date	Comment Format	Commenter	Comment Related to...	Comment	Response (Leading to the final test protocol – Attachment 3)
12/09/2004	Fax	Jim Petersen	Lock-up Tests	<p>the body and bonnet with the pressures shown in the flow schematic and check for leaks in the diaphragm seal or from the body or bonnet with an acceptable leak detection solution.</p> <ul style="list-style-type: none"> The pressure opens the PRV so the same pressure is found in the body and bonnet area. Lockup test must be final flow test since it may be destructive. Record initial lockup & pressure after 1 minute & 5 minutes (note any flow through vent) Using UL 144 for "failure" criteria may be too harsh since high lockups are not an issue with piloted systems (hence the 1 cfm flow test). However, some criteria has to be used and UL 144 is as good as any 	<ul style="list-style-type: none"> Many voiced concern that our criteria for "failure" in the 12/08/2003 test protocol (lock-up > PRD start-to-discharge pressure) was too high and would compromise safety. Many mentioned that higher pressures would compromise the integrity of the resilient disc possibly causing permanent damage; others mentioned that higher lock-up pressures could blow out pilot lights. We agree with these comments and have revised the "failure" criteria to be the same as that listed in UL 144 Table 21.1.
12/15/2004	Email	Jim Griffin	Lock-up Tests	<ul style="list-style-type: none"> UL 144 Section 25.4 uses 250 psi inlet pressure for a lock-up test – this test is only going to measure the inlet sensitivity of the regulator. While it may be a valid test for design, regulators will not experience this condition under normal operating conditions; only if the 1st stage fails on an extremely hot day. 	<ul style="list-style-type: none"> The Lock-up/Flow Tests will be the first test after the visual inspection: <ol style="list-style-type: none"> It is less destructive Allows us to check the initial outlet pressure setting of the regulator and we can then adjust the regulator to the manufacturer's specified outlet pressure We will use the lock-up pressure limits specified in UL 144 Table 21.1 as an indication of regulator problems. We eliminated the Lock-up test for 2nd stage regulators at 250 psig inlet pressures. It was felt that this test was too extreme for a couple of reasons: <ol style="list-style-type: none"> It is difficult to maintain tank pressures of 250 psig even on extraordinarily hot days (cooling from evaporation of liquid propane will keep pressures lower than this maximum value) – discussed by Sam McTier in 12/16/2004 teleconference. This test relies on the fact that the 1st stage regulator fails – this is not a normal operational/ performance issue, it is based on an extreme situation. During the initial lock-up tests (100 psig for 1st and single stage; 10 psig for 2nd stage) we will block in the regulator and monitor for leaks and flow through the vent over a 3-minute time period – it is felt that this is sufficient time to determine problems with
12/28/2004	Email	Gary Koch	Lock-up Tests	<ul style="list-style-type: none"> Based on experience, a great majority of low pressure (11" WC) outlet regulators will lock-up below 16" WC – when inspected the resilient disc will have indentations but not damage that would cause failure Regulators tested to lock-up pressures >20" WC, the discs are badly indented or have evidence of foreign material imbedded in the surface with damage to the extent that I could not justify the regulator remaining in service. Based on the ANSI standard and experience, thinks that it would be improper to accept a standard for regulators to remain in service that have a lock-up pressure above 20" WC for any low pressure regulator Feels it would be difficult to justify an acceptable lock-up pressure based on the relief valve maximum discharge since this is a limit established on the regulator not operating properly For 1st stage regulators – testing at 25 psig is not necessary since we know lock-up will be greater at 100 and 250 psig For 2nd stage regulators – testing at 5 and 10 psig is not necessary; inlet flow of 15 psig is more consistent with the max outlet from 1st stage regulators and 250 psig would give results when there is a possible failure of the 1st stage regulator. Outlet pressure should be recorded for a high flow rate then decrease to a minimum flow (pilot flow - ~0.2 cfm/500 BTU/hr) – want to know of any high outlet 	<ul style="list-style-type: none"> We eliminated the Lock-up test for 2nd stage regulators at 250 psig inlet pressures. It was felt that this test was too extreme for a couple of reasons: <ol style="list-style-type: none"> It is difficult to maintain tank pressures of 250 psig even on extraordinarily hot days (cooling from evaporation of liquid propane will keep pressures lower than this maximum value) – discussed by Sam McTier in 12/16/2004 teleconference. This test relies on the fact that the 1st stage regulator fails – this is not a normal operational/ performance issue, it is based on an extreme situation. During the initial lock-up tests (100 psig for 1st and single stage; 10 psig for 2nd stage) we will block in the regulator and monitor for leaks and flow through the vent over a 3-minute time period – it is felt that this is sufficient time to determine problems with

Comments on regulator test protocol and associated justification for the revised protocol

Date	Comment Format	Commenter	Comment Related to...	Comment	Response (Leading to the final test protocol – Attachment 3)
12/16/2004	Email	David Stainbrook	Lock-up/Flow Tests	<p>pressures at min flow that could cause problems of pilot outage or improper ignition of automatic gas ignition systems & components. For the 0.2 cfm flow – any pressure higher than 16" WC should be considered as a failure.</p> <ul style="list-style-type: none"> Inlet pressure should be observed for 2-3 minutes to assure there is no creeping of the outlet pressure; then isolate the inlet pressure to observe the outlet pressure for any pressure decay resulting from leaks either at the seals or through the vent; then soap the regulator exterior and vent to identify the source. This test would not be destructive and is more representative of field conditions for outlet pressures Once the order of the tests are changed (Lock-up/Flow; PRD; leakage) then the parameters we have laid out are fine 	<p>the regulator (leaks, pressure fluctuations, relief venting)</p> <ul style="list-style-type: none"> Lock-up tests will still be run at the 3 pressures previously mentioned in the 12/08/2004 test protocol; however the order in which the pressures will be tested has changed. <ol style="list-style-type: none"> 1st stage and single stage regulators – initial Lock-up/Flow Test at 100 psig, then 25 psig, then 250 psig - represents typical press., low press., and high press. for the test sequence. Additionally, the first test at 100 psig will start at a typical residential flow of 30 cfm (75,000 BTU/hr) to adjust the regulator; subsequent tests will start at 80 cfm then lower to 30 cfm, 0.5 cfm, and then lock-up (data will be taken at these specific flows)
03/20/2005	Email	Jeff Borton	Lock-up/Flow Tests	<ul style="list-style-type: none"> How is it determined whether a regulator will be tested at the residential or commercial flow rate? Under the failure criteria for the 2nd stage 250 psig test, the less than (<) sign should be a greater than (>) sign. 	<ol style="list-style-type: none"> 2. 2nd stage regulators – initial Lock-up/Flow Test at 10 psig, then 5 psig, then 15 psig - represents typical press., low press., and high press. for the test sequence. Additionally, the first test at 100 psig will start at a typical residential flow of 30 cfm (75,000 BTU/hr) to adjust the regulator; subsequent tests will start at 80 cfm then lower to 30 cfm, 0.5 cfm, and then lock-up (data will be taken at these specific flows)
12/16/2004	Email & Fax	Sam McTier	Lock-up/Flow Tests	<p>For 1st and single stage regulators:</p> <ul style="list-style-type: none"> Set the inlet pressure to 100 psig with a flow of 75,000 BTU/hr (30 cfm) with an outlet pressure of 10 psig for 1st stage and 11" WC for single stage Then shutdown the flow from the outlet and record the lock-up pressure to make sure it does not exceed the max lock-up pressure in UL 144 Next increase flow to 200,000 BTU/hr and 500,000 BTU/hr and record the outlet pressures. Without changing the outlet pressure settings run the same tests with a 25 psig inlet pressure and a 200 psig inlet pressure An inlet pressure of 250 psig is impractical to sustain in a normal installation <p>For 2nd stage regulators:</p> <ul style="list-style-type: none"> Set the inlet pressure to 10 psig with a flow of 75,000 BTU/hr (30 cfm) with an outlet pressure of 11" WC Then shutdown the flow from the outlet and record the lock-up pressure to make sure it does not exceed the max lock-up pressure in UL 144 Next increase flow to 200,000 BTU/hr and 500,000 BTU/hr and record the outlet pressures. Without changing the outlet pressure settings run the same tests with a 7 ½ psig inlet pressure <p>From Phone Conversation 12/16/2004</p> <ul style="list-style-type: none"> If lock-up pressures are too high they could potentially blow out a pilot light – this is a safety issue Need to test lock-up in the range of pilot light flows 	<ul style="list-style-type: none"> The lower flow rate (0.5 cfm) is chosen to represent typical flows for pilot lights; the middle flow of 30 cfm represents typical residential flows; and the high flow rate of 80 cfm is chosen to represent typical maximum flow rates. Commercial flow rates will not be tested; the maximum flow rate will be 80 cfm.

Comments on regulator test protocol and associated justification for the revised protocol

Date	Comment Format	Commenter	Comment Related to...	Comment	Response (Leading to the final test protocol – Attachment 3)
03/20/2005	Email	Jeff Borton	Material Testing	<ul style="list-style-type: none"> Changes can occur to the regulator materials of construction because of age and environment; has material testing been considered to further understand if degradation has occurred due to harsh environments? 	<ul style="list-style-type: none"> No
12/09/2004	Email	Jim Petersen	PRD Tests	<ul style="list-style-type: none"> Must be after flow tests since it may be destructive (may not be repeatable due to seal adhesion) 	<ul style="list-style-type: none"> Many commenters voiced concern about using a soapy water solution to detect the PRD start-to-discharge pressure:
12/16/2004	Email	David Stainbrook	PRD Tests	<ul style="list-style-type: none"> Should be more concerned about when the PRD starts to discharge and when it reseats than with relief flow capacity The use of soap solution to measure when a PRD opens and reseals is not the best choice: <ol style="list-style-type: none"> For 2nd and single stage a water manometer should be installed at the outlet with back pressure slowly applied. When the PRD opens, the manometer will stop rising. Stop back pressure, the manometer will drop but stops when reseal is achieved. 1st stage regulators will use a pressure gauge rather than manometer and follow the same process as above A number of 1st stage regulators will not have an integral PRD (no NFPA 58 or UL 144 requirement until 1995) 	<ol style="list-style-type: none"> Too difficult to determine s-t-d based on a bubble solution The initial bubble might not be the actual s-t-d but the diaphragm moving causing flow out of the spring casing <ul style="list-style-type: none"> Because of this concern we have decided to use a pressure transducer to identify the s-t-d pressure (for 2nd stage regulators it may later be decided to use a water manometer to detect the lower pressure changes) Although a number of commenters mentioned that they see no need to measure the relief flow capacity, we will continue to measure it as part of the 1st and single stage PRD tests. It at least provides another data point and we don't feel that it will compromise the tests in any way. We feel that if a pressure relief device does not have sufficient flow, then there is a problem with its relieving capacity and potentially regulator safety.
12/16/2004	Email	Ron Czischke	PRD Tests	<ul style="list-style-type: none"> Minimum flow for a Type I device is 40DP with D being no less than 1/8" 	<ul style="list-style-type: none"> In the test protocol sent out on 12/08/2004 we stated that for 1st and single stage regulators we would continue to raise the pressure to 5 psig above the s-t-d pressure to measure relief flow capacity. After much discussion, we have decided that 3 psig above the s-t-d pressure is sufficient to record the necessary flow data.
12/16/2004	Email & Fax	Sam McTier	PRD Tests	<ul style="list-style-type: none"> Check the PRV opening and closing pressures by attaching a line with a restrictive orifice to the outlet of each regulator. Slowly raise the pressure to outlet until the PRV opens – record the pressure to ensure it is within the limits shown in UL 144. Then shutdown the flow to the outlet and record the PRV closing pressure You do not need to use soapy water – just look at the pressure gauge We do not need to know the flow rate of the PRVs The only real concern is that the outlet pressure of 2nd stage regulators never exceeds 2 psig with total seat failure with a 15 psig inlet pressure 	<ul style="list-style-type: none"> The high side failure criteria will be based on the manufacturers outlet pressure as we have now decided to adjust the regulators prior to testing; therefore the selected criteria should still be valid. Agree with Jeff's last comment; we will not be measuring relief flow for 2nd stage regulators.
12/16/2004	Email	David Stainbrook	PRD Tests	<ul style="list-style-type: none"> Relief flow capacity data is of little value for performance testing (more for design). 	
03/20/2005	Email	Jeff Borton	PRD Tests	<ul style="list-style-type: none"> The low side failure criteria for the PRD s-t-d of < 140% for 1st stage and < 170% for single and 2nd stage regulators should be replaced with the requirement that the s-t-d must be > than the lock-up pressure. The PRD reset pressure failure criteria should be replaced with the requirement that the reset pressure must be greater than the lockup pressure for that individual regulator. The high side failure criteria for the PRD s-t-d are 	

Comments on regulator test protocol and associated justification for the revised protocol

Date	Comment Format	Commenter	Comment Related to...	Comment	Response (Leading to the final test protocol – Attachment 3)
				<p>defined as a % of the outlet pressure. Since outlet pressures will be "as received" and not reset, the outlet pressure used here must be the actual outlet pressure of each individual regulator, not the set value used in UL144.</p> <ul style="list-style-type: none"> Per UL144 there is no PRD flowrate requirement for 2nd stage regulators with type 2 PRDs. The 2nd stage PRD flowrate should not be tested as this data has no pass/fail criteria. Should define the pressure relief valve discharged not as when the 1st bubble appears from the vent but when a steady stream of bubbles/flow is observed. Intermittent or the 1st bubble may only indicate that the diaphragm is moving in an upward position to cause flow out of the spring case. 	
12/28/2004	Email	Gary Koch	PRD Tests	<ul style="list-style-type: none"> Many of the UL reference parameters are based off the regulator set point. You will find a number of regulators where the adjusting screw has been changed for example to compensate for excessive pressure drop in the system. If you don't establish a consistent set point, the data you generate will be all over the place. 1. Set single stage to 11" WC delivery @ 75,000 BTU (30 cfh) at 75 psig inlet 2. Set 2nd stage to 11" WC delivery @ 75,000 BTU (30 cfh) at 10 psig inlet 3. Set 2nd stage, large capacity to 11" WC delivery @ 100,000 BTU (40 cfh) at 10 psig inlet 4. Set 1st stage to 10, 15, or 20 psig (based on model #) @ 200,000 BTU (80 cfh) at 100 psig inlet <ul style="list-style-type: none"> Not every manufacturer sets the regulators the same way; the capacity of the regulator can affect how the set point is determined. Without an accurate set point your data will be suspect. Do not adjust the regulator - disagreed with Sam McTier 	
12/16/2004	Email	David Stainbrook	Regulator Adjustment	<ul style="list-style-type: none"> All regulators are required to be marked by the manufacturer with the outlet pressure setting. After the initial visual inspection, it would be nice to note the outlet pressure "as received" Any tests of the regulator should be done after the regulator outlet pressure is adjusted to the manufacturer's marked setting; the tests will only be meaningful if the regulator outlet pressure is set at the manufacturer's marked setting. Set the regulators in the Lock-up/Flow Tests: <ul style="list-style-type: none"> 1. For 1st, single stage, automatic changeover and integral 2-stage; set the inlet pressure to 100 psig with a flow of 75,000 BTU/hr (30 cfh) with an outlet 	<ul style="list-style-type: none"> Our initial thoughts in both the protocol distributed on 11/04/2004 and 12/08/2004 were to not adjust the regulators prior to testing. The thinking involved the fact that we did not want to tamper with the regulators in any way that might jeopardize the testing results. After many discussions and comments from those involved, we have reconsidered and decided that it would be best to adjust the regulators to the manufacturer specified outlet pressure prior to testing. The procedure is as follows: <ol style="list-style-type: none"> For 1st and single stage regulators: start with an inlet pressure of 100 psig (per UL 144 Section 17.3) and flow rate of 30 cfh (75,000 BTU/hr) – representing average pressures and flow rates that a regulator may experience over a year. For 2nd stage regulators: start with an inlet pressure of 10 psig (per UL 144 Section 17.3) and flow rate of 30 cfh (75,000 BTU/hr) – representing average pressures and flow rates that a regulator may experience over a year. Note the initial outlet pressures before any regulator adjustment is performed Adjust the regulator to the manufacturer specified outlet pressure (single and second stage 11" WC; 1st stage 10, 15 or 20 psig) and continue with Lock-up/Flow test starting at 30 cfh, then 0.5 cfh, then lock-up.
12/16/2004	Email	Ron Czischke	Regulator Adjustment		
12/16/2004	Email & Fax	Sam McTier	Regulator Adjustment		

Comments on regulator test protocol and associated justification for the revised protocol

Date	Comment Format	Commenter	Comment Related to...	Comment	Response (Leading to the final test protocol – Attachment 3)
				<p>pressure of 10 psig for 1st stage and 11" WC for single stage, automatic changeover, and integral 2-stage</p> <p>2. For 2nd stage: set the inlet pressure to 10 psig with a flow of 75,000 BTU/hr (30 cfm) with an outlet pressure of 11" WC</p> <p>Settings for Max. Capacity Ratings (Fax)</p> <ol style="list-style-type: none"> 1. Single stage, integral 2-stage, and automatic changeover: set the inlet pressure to 25 psig with a minimum outlet pressure setting of 10" WC (9" alternative and reverse side for automatic changeover) 2. 1st stage: set the inlet pressure to 25 psig with a minimum outlet pressure setting of 7.5 psig 3. 2nd stage: set the inlet pressure to 7.5 psig with a minimum outlet pressure setting of 10" WC (9" alternative) 	<ol style="list-style-type: none"> 5. Block-in the regulator to check for leaks and/or pressure decay over a 3-minute period 6. Open inlet valve and adjust flow up to the maximum flow rate of 80 cfm 7. Continue with Lock-up/Flow tests without further adjustment to regulator
12/16/2004	Email & Fax	Sam McTier	Reporting	<ul style="list-style-type: none"> We should keep track of the # of regulators received that have nothing wrong with them and their percentage of the total # of regulators received A breakdown of why regulators have failed should be clearly stated 	<ul style="list-style-type: none"> We will document all findings from each regulator tested including performing failure analysis for a representative sample.
12/16/2004	Email & Fax	Sam McTier	Safety Issues	<ul style="list-style-type: none"> Doesn't know how we can separate safety issues from performance issues – inadequate or failed performance of a propane regulator usually leads to a serious safety issue. 	<ul style="list-style-type: none"> OK
03/20/2005	Email	Jeff Borton	Statistical Sampling	<ul style="list-style-type: none"> How is the appropriate mix of regulators determined and controlled? The mix would need to ensure a statistically significant quantity is obtained from various locations, environments, applications, and manufacturers. What information was the propane marketer asked to include? – minimum information should be location of use, environment description, application description, how often serviced, etc. 	<ul style="list-style-type: none"> We will be using statistical analyses (based on regulator age, manufacturer, geographic location, type) to select the regulators for testing. Propane marketers were provided with information tags to fill out with information about the regulator, its installation, and its use.
03/05/2005	Email	Jeff Borton	Test Protocol	<ul style="list-style-type: none"> Some of the testing is per the latest revision of UL 144. Regulators will likely have been manufactured to an earlier version – they should be tested to the applicable standard in place at the time of manufacturer. 	<ul style="list-style-type: none"> The original regulator testing sequence (from 12/08/2004 protocol) involved: <ol style="list-style-type: none"> 1. Visual inspections (internal/external) 2. Leakage test 3. PRD/Flow Capacity test 4. Lock-up/Flow test Many of the commenters agreed that this test sequence was not the best method for testing the regulators. Some of the reasons included:
12/09/2004	Email	Jim Petersen	Test Sequence	<ul style="list-style-type: none"> Rearrange test order so that the flow tests are first, then lockup, then PRV tests, and last the leakage test 	
12/15/2004	Email	Jim Griffin	Test Sequence	<ul style="list-style-type: none"> Strongly recommends after visual inspections that the test order be rearranged as follows: <ol style="list-style-type: none"> 1. Lock Up/Flow test 2. Relief valve test 3. Leakage test Reason for change – the test method will back pressure the regulator well above normal operating conditions causing the main disc to close very tightly against the 	

Comments on regulator test protocol and associated justification for the revised protocol

Date	Comment Format	Commenter	Comment Related to...	Comment	Response (Leading to the final test protocol – Attachment 3)
12/16/2004	Email	Ron Czischke	Test Sequence	<p>orifice. It will also open the internal relief valve as you go above the set-point allowing pressure into the spring case compromising the Lock-up and PRV tests.</p> <ul style="list-style-type: none"> • The order of testing should be reversed: <ol style="list-style-type: none"> 1. Flow/lockup 2. Relief valve performance 3. Leakage test • Would not conduct tests in this sequence since the leakage test is at higher pressures and is likely to be destructive (damage to the resilient disc) <ol style="list-style-type: none"> 1. Lock-up/Flow test 2. PRD test 	<ul style="list-style-type: none"> o The back-pressures experienced in the leakage test could be destructive to the regulator hence compromising the remaining PRD and Lock-up/Flow test results. o The pressures experience in the PRD/Flow Capacity Tests will also be higher than those for the lock-up test; therefore this should be conducted after the Lock-up/Flow tests in case they are destructive.
12/28/2004	Email	Gary Koch	Test Sequence	<ul style="list-style-type: none"> • The test limits should be based on the system in which these regulators will be installed. • We are taking regulators from service and most, if not all, have been in applications where there is a standing pilot light (water heater) • We must consider and establish any acceptable table limit based on applications where there will be no standing pilot in the future (furnaces; gas ranges) • Also consider the ANSI standards that have established pressures for testing controls and appliances – ANSI Z21.78 (standard for combination gas controls for gas appliances) the pressure given for leakage is 21" WC for a standard 11" WC setting 	<ul style="list-style-type: none"> • Based on all of the feedback, we agree that the test sequence should be reversed from that specified in the 12/08/2004 protocol. Additionally, we agree that the UL 144 leakage test is more of a design specification than a performance specification and have removed it from the test protocol (see Leakage Test section). The new test sequence is as follows: <ul style="list-style-type: none"> • Visual Inspection (Internal/external) • Record initial regulator outlet pressure • Adjust regulator to manufacturer specified outlet pressure • Lock-up/Flow Tests (check for leaks by blocking in regulator) • PRD/Flow Capacity Tests
12/28/2004	Email	Gary Koch	Testing Requirements	<ul style="list-style-type: none"> • Should include any evidence of contaminants 	<ul style="list-style-type: none"> • Agree – we will note any contaminants found during the visual exam
12/16/2004	Email	Ron Czischke	Visual Inspection	<ul style="list-style-type: none"> • A set of criteria should be provided to the personnel performing the inspection to consistently grade and record what they see. For example, light oxidation or severe corrosion; visual corrosion standards might be helpful to obtain consistent data. 	<ul style="list-style-type: none"> • We will not replace any missing bonnet caps on regulators we receive. We feel that a missing bonnet cap casts too many questions about the regulator that we don't feel it should be tested.
03/20/2005	Email	Jeff Borton	Visual Inspection	<ul style="list-style-type: none"> • If a bonnet cap is missing on a regulator, it should be replaced and the regulator should be tested 	
12/16/2004	Email & Fax	Sam McTier	Visual Inspection		

APPENDIX C

Inspections of “Failed” Regulators

Appendix C – Failure Analysis on Selected Regulators

Several of the regulators identified as “failures” were selected for detailed failure analysis to determine possible failure mechanisms and environmental variables that contributed to the failure. The regulators selected for failure analysis are presented in the table below. Detailed analyses follow.

Regulator ID	Manuf.	Age	Climate	State	Service Area	Reason for Removal	Reason for not meeting UL Criteria
13 (2-stage)	A	13	Warm, Damp	AL	Rural	Faulty regulator; no pressure at regulator outlet	High lock-up pressure
42 (second)	B	16	Warm, Dry	IL	Suburban	End of manufacturer’s recommended service life	High lock-up pressure
72 (second)	A	16	Cool, Dry	CO	Rural	Tank and regulator removed from service	Chatters and leaks through PRD at 10 psig inlet pressure and 30 cfh.
353 (single)	A	15	Warm, Damp	MS	Rural	End of manufacturer’s recommended service life	Chatters and leaks through PRD at 100 psig inlet pressure and 30 cfh.
361 (first)	B	27	Warm, Dry	CA	Urban	Tank and regulator removed from service	PRD start-to-discharge and reseating pressures too low; dirty exterior; clean interior; could not adjust
383 (single)	B	43	Cool, Dry	SD	Rural		PRD start-to-discharge pressure too high in first trial; high lock-up
490 (2-stage)	B	6	Warm, Damp	FL	Suburban	Changed from single to dual regulator system	Chatters and leaks through PRD at 100 psig inlet pressure and 30 cfh.
538 (first)	A	16	Warm, Dry	PA	Suburban	Tank and regulator removed from service	Leak through PRD at 25 psi inlet pressure and 0 cfh; high lock-up pressure
571 (first)	B	10	Cool, Damp	MI	Rural	Faulty regulator	Leaked through PRD during adjustment
711 (second)	A	27	Cool, Dry	SD	Rural	End of manufacturer’s recommended service life	PRD did not relieve after reaching 65” W.C.

Failure analysis Regulator #13

Problem

This integral twin stage regulator was removed from service because there was “no pressure at the regulator outlet”. During testing the regulator exhibited “high lockup”. A representative plot of the data taken during testing is shown in Figure 1.

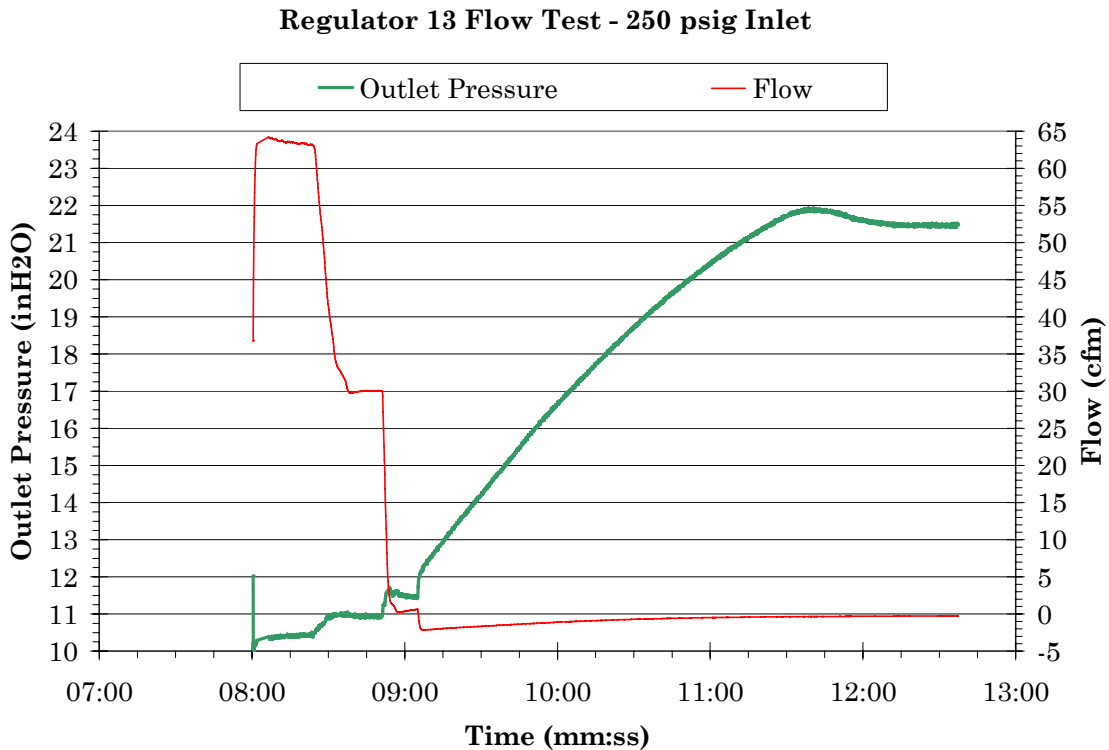

Figure 1: Regulator 13 Flow Test

All the medium pressure inlet (100 psig) and high pressure inlet (250 psig) flow tests indicated similar results. Specifically, at lock-up the outlet pressure gradually increased to approximately 20 in.w.c. over a two to three minute time span. For the low pressure inlet (25 psig) flow test, the outlet pressure remained relatively constant at lock-up, approximately 12.2 in.w.c..

This data suggests that there is a leak path between the inlet and outlet of one of the two stages. A leak through either stage could cause the same behavior as shown in the plot, either by overpressure on the second-stage inlet or a direct leak through the second-stage.

Inspection

The outside of the regulator body is in good condition. There is some chipped and scratched paint on the surface, but no major damage to the body. The vent screen is in place and clear.

Failure Analysis Regulator #13



Figure 2: Regulator #13

The inside of the second-stage portion of this regulator was fairly clean, as shown in Figure 3. There was a small amount of dirt and corrosion on the diaphragm plate and small amounts of debris on the upper surface of the diaphragm. There was also some corrosion on the bottom of the adjustment spring plate as shown in Figure 4.



Failure Analysis Regulator #13

Figure 3: Top of Second-Stage Portion (Regulator #13)



Figure 4: Bottom of Adjustment Spring Plate (Regulator #13)

The diaphragm itself was in excellent condition. A few creases were observed on the top surface of the diaphragm, most noticeably at 6 o'clock in Figure 5. However there was no evidence of cracking or fatigue due to the creases. Some oily residue was observed on the lower surface of the diaphragm, most apparent where the diaphragm contacts the body as shown in Figure 6. There was no evidence that the oil damaged the integrity or functionality of the diaphragm. The sealing surfaces of the diaphragm, both with the body and the PRD, were clean and in good condition.



Failure Analysis Regulator #13

Figure 5: Top of Second-Stage Diaphragm (Regulator #13)



Figure 6: Bottom of Second-Stage Diaphragm (Regulator #13)

The lower half of the body of the second-stage portion of the regulator was remarkably clean. There were a few large chunks of some foreign material in the bottom half of the body. The largest of these is circled in Figure 7 and shown in more detail in Figure 8. The material was suspected to be remnants of pipe dope used during the installation of the regulator. The coloring of the material was similar to that of the pipe dope found on the outlet threads of the regulator. Additionally, like dried pipe dope, the chunks of material could be crushed to a fine powder by applying sufficient force. It is worth noting that for the second-stage inlet to be fully closed, the PRD stem is raised. For full-open, the PRD stem is lowered (and most likely to have its motion inhibited by the debris). So it is possible the debris blocked the opening of the second-stage, resulting in a maximum flow of 65 scfm (Figure 1) rather than the 80 scfm target.

Failure Analysis Regulator #13



Figure 7: Bottom Body of Second-Stage (Regulator #13)



Figure 8: Close-up of Debris in Bottom Body of Second-Stage (Regulator #13)

The inlet to the second-stage (outlet of the first-stage) is shown in Figure 9. There was a large amount of dark particulate debris, as well as some small metal shavings. It is undeterminable if these were in the regulator while assembled, or if they were deposited by debris from the disassembly. The screws holding together the two halves of the first-stage were rusted in place and difficult to remove. (Note the screw that sheared during removal in

Failure Analysis Regulator #13

the upper left corner of Figure 9). So the debris and metal shavings could have come from the corroded screws as they were removed.

Due to the construction of the linkage assembly, it was impossible to remove the assembly and inspect the seal on the rubber inlet. No major wear or cuts were observed by the limited inspection. As with the rest of the body, a small amount of debris and metal shavings from an undeterminable source were found on the rubber.



Figure 9: Inlet to the Second-Stage (Outlet of the First-Stage) (Regulator #13)

The first-stage plate is shown in Figure 10. A small amount of debris was found on the rubber face. Given it's somewhat shielded location in the assembly, it is more probable (but cannot be guaranteed) that the debris had been on the rubber face while the regulator was assembled. There was no debris, nor imprints of where debris had been, on the seal line of the rubber.

Failure Analysis Regulator #13



Figure 10: First-Stage Plate (Regulator #13)



Figure 11: First-Stage Outlet (Regulator #13)

The first-stage diaphragm is shown in Figure 12. The diaphragm was less flexible than the second-stage diaphragm. Clear indentations were left on the diaphragm on all sealing edges. A small tear in the diaphragm on the inlet side was observed (at 3 o'clock in Figure 12). The tear did not extend through the sealing edge of the pass through (Figure 11). The diaphragm appeared to be constructed of a woven layer sandwiched by rubber layers. The

Failure Analysis Regulator #13

tear extended through the depth of the rubber layer on the inlet side, but not through the woven layer or the other rubber layer.

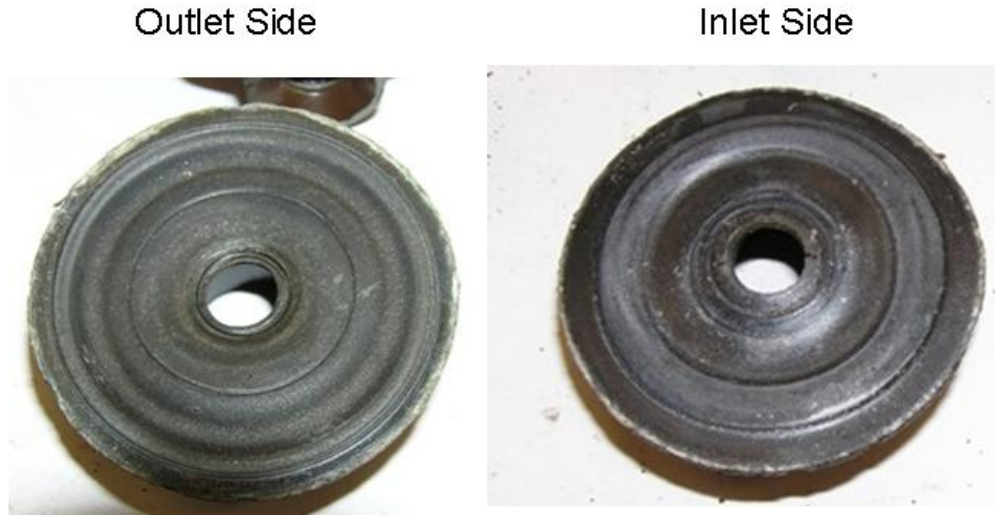

Figure 12: First-Stage Diaphragm (Regulator #13)

Summary

Dried remnants of pipe dope found in the second-stage body are likely to have prevented the full opening of the second-stage inlet and therefore the subsequent failure of this regulator to allow a flow of 80 scfm.

The testing data indicates the high lock-up pressure is probably due to a small leak through the face seals on the rubber surfaces of either the first or second stages (Figures 9 and 10). No conclusive evidence of debris creating a leak path was found due to the limited accessibility of the second-stage surface and the amount of debris generated during inspection that could have affected the first-stage and second-stage observations.

Two leak path hypotheses are proposed. Firstly, it is possible that some of the debris found during inspection was indeed preventing proper sealing of the interface. Secondly, there is some variability in the movement of the parts that create the seal during lock-up. Both rubber portions of the seals showed signs of permanent deformation. Perhaps there was enough tolerance in the relative movement of the parts that allowed a slight misalignment of the sealing interface over a permanently deformed ring, thereby creating a leak path.

Failure Analysis Regulator #353

Problem

This second-stage regulator failed testing due to slow lockup and high lockup pressures. A typical flow test plot is shown in Figure 1. At lockup the outlet pressure increases to a steady value around 22 inH2O.

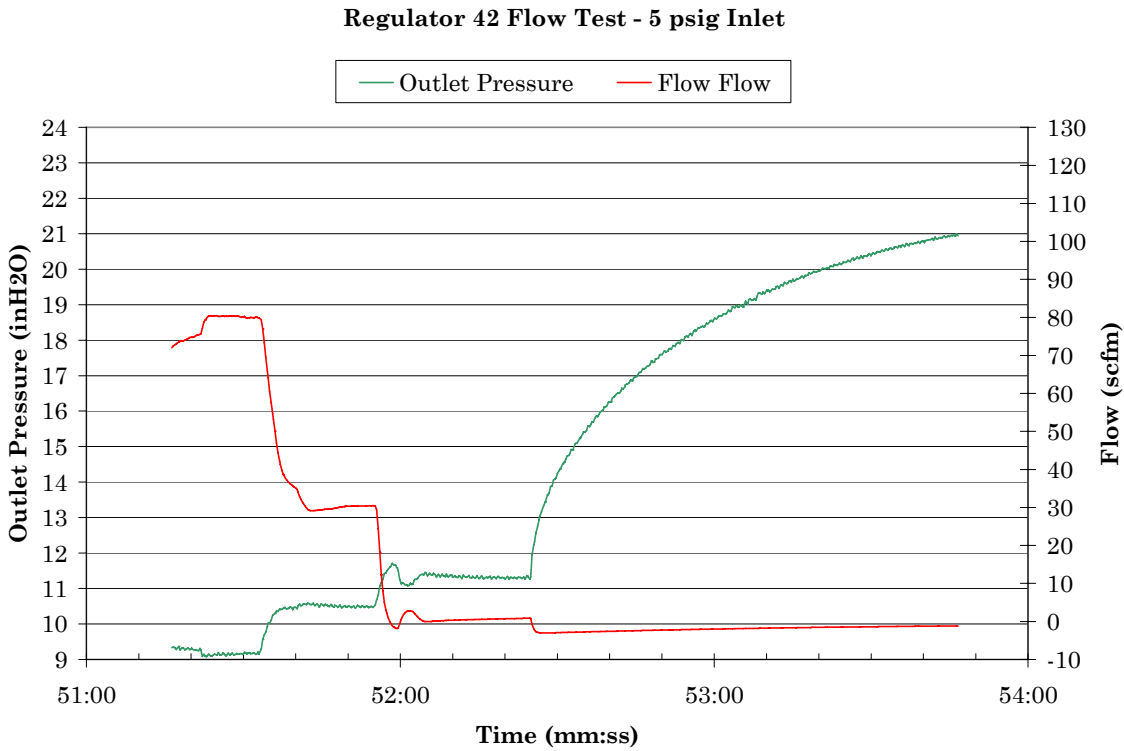

Figure 1: Regulator #42 Flow Test, Low Inlet Pressure

Inspection

The regulator body is in good condition, as shown in Figure 2.. There were small amounts of dirt on the body and slight corrosion on or around the screws that hold the two halves of the body together.

Failure Analysis Regulator #353



Figure 2: Regulator #42

A small piece of debris was observed on the inlet seat disc as shown in Figure 3. The piece of debris was removed and measured to be approximately 1/8" x 1/16" x 1/32". Based on the amount of pipe dope on the regulator inlet (Figure 3) it is quite possible this piece of debris is simply a small fragment of dried pipe dope that fell into the inlet after testing was completed, and therefore not the root cause of the failure.



Figure 3: Debris Found on Inlet of Regulator #42

Failure Analysis Regulator #353

The upper half of the regulator body was removed and the diaphragm inspected. The diaphragm was found in good condition. No tears, scratches, cracking, or other signs of damage were observed. The adhesive bonding the diaphragm to the diaphragm plate was not very strong; it was easy to separate the two parts. However, since the adhesive is not a pressure sealing interface, the quality of the adhesive will not affect regulator performance.

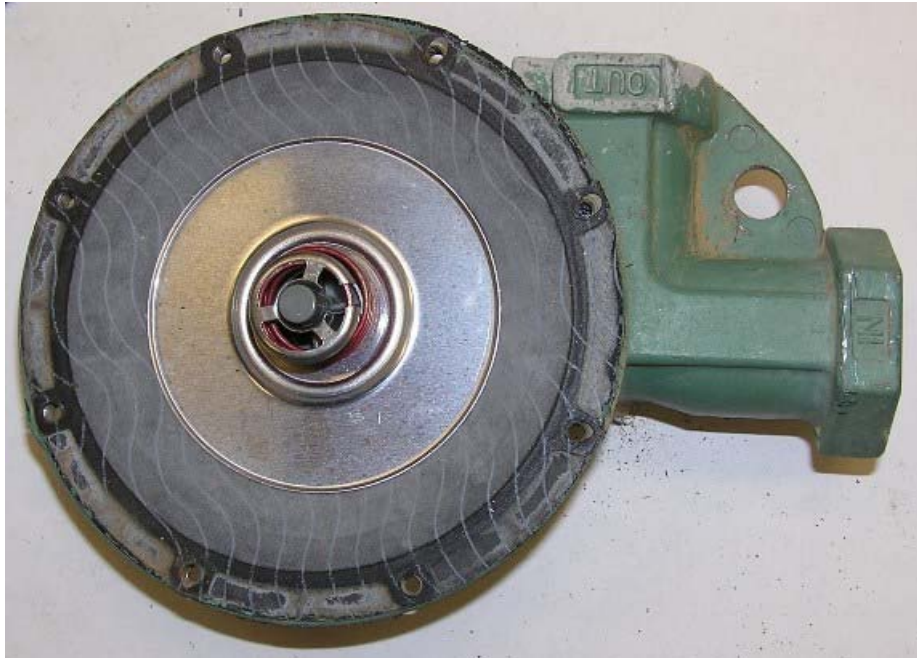

Figure 4: Regulator #42 Diaphragm and Diaphragm Plate

The underside of the diaphragm was found to be in good condition, as shown in Figure 5. The sealing interface between the PRD stem and the diaphragm was in excellent condition. A clear, uniform mark of the interface was observed. There were no indications of any potential leak paths through this seal.

Failure Analysis Regulator #353



Figure 5: Underside of Regulator #42 Diaphragm

The nozzle orifice piece was removed from the regulator inlet. Noticeable damage to the seat disc was observed (Figure 6). Note that the regulator has been rotated relative to Figure 3. Accounting for this rotation, the piece of debris observed there was found at approximately 2 o'clock in Figure 6 and the damage shown is found at 10 o'clock. Due to the construction it was not possible to easily remove the seat disc from the body. Therefore, it was difficult to examine the damage to the seat disc in detail. The marks found on the seat disc appeared to indicate both compression of the seat disc by a foreign body as well as a small amount of material removal from the seat disc.

The cause of the damage did not appear to be the nozzle orifice. It is shown in Figure 7. The edge of the orifice is smooth and clean with no nicks or sharp edges that could cut the seat disc.

Failure Analysis Regulator #353



Figure 6: Damage to Inlet Seat Disc of Regulator #42



Figure 7: Nozzle Orifice of Regulator #42

Failure Analysis Regulator #353

Summary

Based on the results of the flow test (Figure 1) and the observed damage on the seat disc (Figure 6), the following failure mechanism is proposed. Under lockup conditions, the damage to the seat disc is a leak path from the inlet to the outlet. At a normal lockup pressure the leak path still is open. As the outlet pressure increases (to approximately 22 inH₂O) the additional pressure is enough to seal the leak path and prevent further increase in the outlet pressure.

The cause of the leak path is undetermined. The piece of debris shown in Figure 3 is a possibility. If this debris is in fact pipe dope, it is much more likely that it would disintegrate (and not damage the seat disc) if it got trapped between the seat disc and the orifice. The bottom half of the regulator body was remarkably clean; no significant amounts of grit or other foreign bodies were found. The outlet opening on the body is relatively large, so it is quite possible that the foreign body that caused the damage fell out of the regulator during transport.

Failure Analysis Regulator #353

Problem

This second-stage regulator “chatters & leaks thru PRD at 10 psig inlet and 30 cfh”. It was removed from the field because the tank and regulator were removed from service.

Inspection

The outside of the regulator body is in good condition. There are no signs of damage or abuse. The regulator functionality was tested before any disassembly or modifications were done. Air was blown through the regulator at lung pressure. When the outlet was open, all the sensible flow left the regulator through the outlet; no leakage through the PRD was found. If the outlet was covered, a small amount of air leaked through the PRD. As the inlet pressure was increased, the leak through the PRD stopped. Due to the small capacity of human lungs, it is possible that leakage through the PRD occurred while the outlet was open. But since the volumetric flow was so low, no discernible flow through the PRD could be observed.

In summary, at low inlet pressures the regulator leaked through the PRD. As the inlet pressure increased, the leak sealed.



Figure 1: Regulator #72

Failure Analysis Regulator #353

During disassembly, the first step was to remove the setpoint spring. The spring was fully compressed.

The diaphragm plate was removed and the upper surface of the diaphragm was inspected (Figure 2). The diaphragm appeared in good condition. No tears, cuts, holes, or any other indication of leakage was found. Small amounts of dirt and other debris were found on top of the diaphragm, but no large or sharp pieces were noted.



Figure 2: Top of Diaphragm (Regulator #72)

The diaphragm was separated from the control linkage and the bottom was inspected. There was a noticeable amount of rust or other debris in the bottom half of the regulator body and on the bottom of the diaphragm (Figure 3). The suspected source is the bell-shaped portion of the control linkage.

Failure Analysis Regulator #353



Figure 3: Bottom Half of Body (Regulator #72)

Near the central hole where the control linkage passes through the diaphragm two observations were noted. Firstly a small, sharp-edged, translucent piece of debris was found. The debris could have been glass, plastic, or another material. The debris was located on the sealing face between the control linkage and the bottom of the diaphragm. Note its location in Figure 4. Additionally, two distinct circles are observed where the seal between the diaphragm bottom and the control linkage. Both of these circles coincide with the location of the translucent debris, indicating that it was perhaps a pivot point for the shift.

Failure Analysis Regulator #353



Figure 4: Debris on Seal Between Diaphragm Bottom and Control Linkage

The piece of translucent debris was removed and saved. A distinct impression was left on the diaphragm where the piece of debris was located (Figure 5).

Failure Analysis Regulator #353



Figure 5: Removed Debris on Seal Between Diaphragm Bottom and Control Linkage

Summary

Based on the observations and inspection notes, the failure mode of this regulator is a leak from the inlet, past the piece of translucent debris, to the top half of the regulator body, and out the PRD.

Failure Analysis Regulator #353

Problem

This single-stage regulator “chatters & leaks thru PRD at 100 psig inlet and 30 cfh”. It had been removed from service since it reached the end of manufacturer’s service life.

Inspection

The assembled body of Regulator 353 was in good condition. There was a fair amount of dirt and insect webs on the outside of the body. The vent screen was in place, and only some small debris was found on the rubber diaphragm that covers the vent. Silver paint coated the body near the regulator inlet, outlet, and vent. Additional silver paint can be seen on the outside edge of the two halves of the body in Figure 1.



Figure 1: Regulator #353 (Cap Removed)

The body was opened and a visible area where some foreign substance had pooled in the body was immediately evident. Figure 2 shows the upper and lower halves of the regulator body. A distinct line across the diaphragm, diaphragm plate and body indicates where the pooling occurred.

Failure Analysis Regulator #353

If the foreign substance entered the regulator body as a liquid, any moisture evaporated well before this regulator was examined. A thin coating of white residue was left, as well as a significant build-up of the substance at the bottom of the pool on the diaphragm plate. The build-up was a finely compressed powder, not loose and dispersible. It was chalky in texture.

If this residue was indeed left by some pool of liquid that accumulated inside the regulator, the angle of the pool is of interest. The parts shown in Figure 2 have not been rotated. Assuming the pooling was due to gravity, the angle of installation was approximately 25° from horizontal (Inlet at 10 o'clock and outlet at 4 o'clock). This is not in accordance with the manufacturers instructions stamped on the body, specifying installation with the vent facing downward.

In addition to the residue from the pool or foreign substance, there was a substantial amount of other debris, flakes, and particles on the inside of the regulator body.



Figure 2: Inside of Regulator #353 Body

The edge of the diaphragm plate where the pool of liquid had resided was slightly corroded, as shown in Figure 3.

Failure Analysis Regulator #353



Figure 3: Corrosion and Residue on Plate (Regulator #353)

Upon removal of the diaphragm plate, a large amount of debris was found on top of the diaphragm and on the pressure relief valve stem (Figure 4). The diaphragm itself appeared in good condition. There was no evidence of cuts, tears, or any other damage due to the debris or rusted edge of the diaphragm plate.

Failure Analysis Regulator #353



Figure 4: Debris on Diaphragm and PRD Stem (Regulator #353)

The bottom half of the regulator body was much cleaner, as shown in Figure 5. A few small specks of the white debris/flakes were found, as was a small quantity of some black particulate near the regulator outlet.

Failure Analysis Regulator #353



Figure 5: Bottom Half of Body (Regulator #353)

The bottom side of the diaphragm had a significant amount of debris on it, as shown in Figure 6. For the most part, the debris on the bottom side of the regulator was much smaller in particle size than that on top. There was a significant amount of debris on the sealing face between the diaphragm and the PRD stem, as shown in Figure 7. This debris was more comparable in size to the particles found on top of the diaphragm, and not on the bottom.

Failure Analysis Regulator #353



Figure 6: Bottom Side of Diaphragm (Regulator #353)

Failure Analysis Regulator #353



Figure 7: Debris on Sealing Surface Between Diaphragm and PRD Stem

Summary

No obvious causes of failures were found during inspection. A significant amount of debris, including evidence of liquid pooling, was found on the top half of the regulator body.

The angle of pooling indicates that either the regulator was not installed in the correct orientation, or that the liquid had accumulated inside the regulator before installation.

If the pooling occurred after installation, the angle indicates the vent was facing somewhat downward, so the accumulation of rainwater inside the regulator is unlikely. The color of the liquid residue (white) is inconsistent with the manufacturer's paint (bronze) and the paint later applied (silver).

Based upon the large amount of the unknown white debris on the top half of the diaphragm, the PRD stem, and the sealing surface between the diaphragm bottom and PRD stem, the following failure mechanism is proposed. A large amount of an undetermined liquid entered the top half of the regulator body before or after installation. Upon evaporation of the liquid, a large amount of particulate matter remained on the top half of the diaphragm and the exposed portion of the PRD stem. The regulator experienced a true excess inlet pressure event, causing the diaphragm to separate from the PRD to relieve the excess pressure. While unseated, a significant quantity of the

Failure Analysis Regulator #353

debris entered the sealing face between the diaphragm and the PRD stem. The debris prevented a proper resealing and the consequential leak through the PRD

Failure Analysis Regulator #361

Problem

This first stage regulator failed due to a low relief start-to-discharge pressure and a low reseating pressure. The S-T-D pressure was approximately 11 psig and the reseating pressure was 10.8 psig. A plot of two sequential relief tests is shown in Figure 1. During testing it was noted that the adjustment spring was fully compressed and the maximum outlet pressure was about 10 psig.

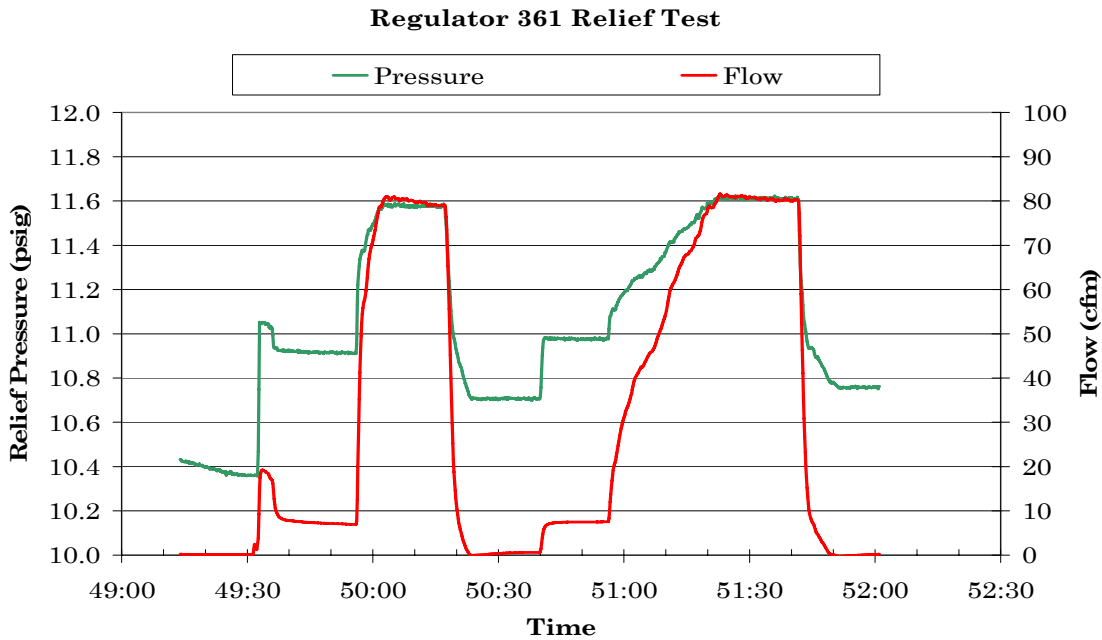

Figure 1: Regulator #361 Relief Test

Inspection

Regulator #361 is shown below in Figure 1. An inspection of the assembled regulator found it to be in acceptable condition. Paint had started to chip off the regulator body, but no damage to the integrity of the body was found. There was some corrosion of the bolts holding the two halves of the body together. Small amounts of dirt were found on the outside of the regulator body.

Failure Analysis Regulator #361



Figure 2: Regulator #361

The upper half of the regulator body was removed and the inside of the regulator was inspected (Figure 3). A noticeable amount of dirt and debris were found on the upper surface of the diaphragm and plate. The diaphragm itself appeared to be in good condition. The mark noticeable at 12 o'clock is not indicative of any damage to the diaphragm integrity; it appears to be a stray spot of adhesive used to bond the diaphragm to the plate. The PRD spring was found in good condition.



Figure 3: Diaphragm and Diaphragm Plate of Regulator #361

Failure Analysis Regulator #361

It was noted that marks on the diaphragm plate indicate the set point spring was off center. There are scratches on the raised lip of the plate at approximately 10 o'clock, as shown in Figure 4. Given the freshness of the marks (bright silvery metal is exposed, rather than corrosion) it is likely they were made during disassembly.



Figure 4: Scratches on Regulator #361 Diaphragm Plate

The diaphragm and plate assembly were removed and inspected. The top surface of the diaphragm was in good condition. A large cut was observed on the bottom surface of the regulator. This cut was at 3 o'clock in Figure 3 (very near the regulator outlet). The cut was approximately 3/8" in length. The depth of the cut reached a woven layer within the diaphragm. It did not appear to extend through the diaphragm to the upper side. An inspection of the top side of the diaphragm at the location of the cut did not identify any evidence that the cut extended through the diaphragm.

Failure Analysis Regulator #361



Figure 5: Cut on Bottom of Regulator #361 Diaphragm

An inspection of the lower half of the regulator body did not find any potential causes for the cut. The cut was located approximately above the regulator outlet. Figure 6 shows this portion of the lower half of the regulator body. All edges were smooth and rounded. There were no sharp edges or foreign bodies found that would have caused the cut.

With the exception of the cut, the rest of the diaphragm was in good condition. The seal between the PRD stem and the diaphragm was distinct and uniform in quality, as shown in Figure 7. There were small particles of dirt or other debris, but there was no evidence that these had interfered with the seal. A small nick was noted on the edge of the PRD stem (1 o'clock in Figure 7). It was barely noticeable, and the uniform quality of the impression on the diaphragm indicates that it didn't affect the quality of the seal.

Failure Analysis Regulator #361



Figure 6: Bottom Half of Regulator #361 Body



Figure 7: PRD Stem and Seal with Diaphragm

Failure Analysis Regulator #361

Summary

No specific cause for the low S-T-D pressure was found. Bits of evidence lead to many possible causes, but no single conclusive cause.

The scratches on the diaphragm plate indicate that the setpoint spring may have been installed off center. If that was the case, it would exert an uneven force on the plate, and the balancing force on the PRD stem seal would also be unbalanced. This could cause the PRD seal to open at a lower pressure. However the lack of corrosion on those scratches indicates they were probably made during the inspection, and not during the service life of the regulator.

The cut on the bottom of the regulator could also be a cause for the low S-T-D pressure. Although no evidence that this cut extended through the entire diaphragm was found, it is possible a small leak path opens at a pressure of 10 psig.

Failure Analysis Regulator #383

Problem

This single-stage regulator was noted to have high lock-up pressure. A plot of a typical flow test is shown in Figure 1.

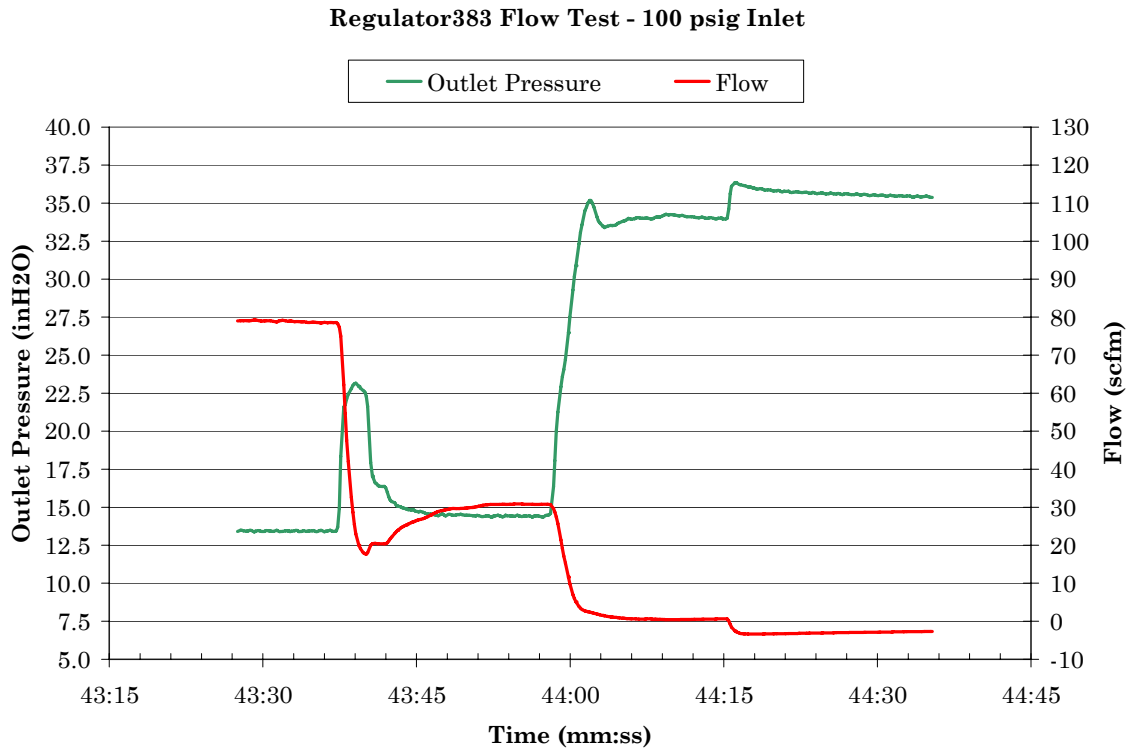

Figure 1: Regulator #383 Flow Test (100 psig Inlet)

Inspection

The outer body of Regulator #383 was found in good condition, as shown in Figure 2. There was some buildup of dirt on the body surfaces, but none appeared to interfere with the functionality of the regulator.

Failure Analysis Regulator #383



Figure 2: Regulator #383

The upper half of the body was removed and the diaphragm was inspected (Figure 3). The inside of the regulator was very clean. The diaphragm was found to be in good condition, with no cuts or scrapes. Yellow paint was noted on the diaphragm plate. This color and location matches the color and location of paint on the set-point spring, indicating the spring was painted during assembly. The diaphragm was thinner than typically noted during the regulator inspections.

The underside of the diaphragm was also found to be in good condition, as shown in Figure 4. Slight discoloration of the diaphragm was noted. The irregular ring that appears darker (marked with an arrow in Figure 4) corresponds exactly to the location of the adhesive bonding the diaphragm to the plate. Beyond the discoloration, there was no indication that the adhesive damaged the integrity of the diaphragm. Small amounts of fine grit were observed near the edge of the diaphragm.

Failure Analysis Regulator #383



Figure 3: Diaphragm and Plate of Regulator #383

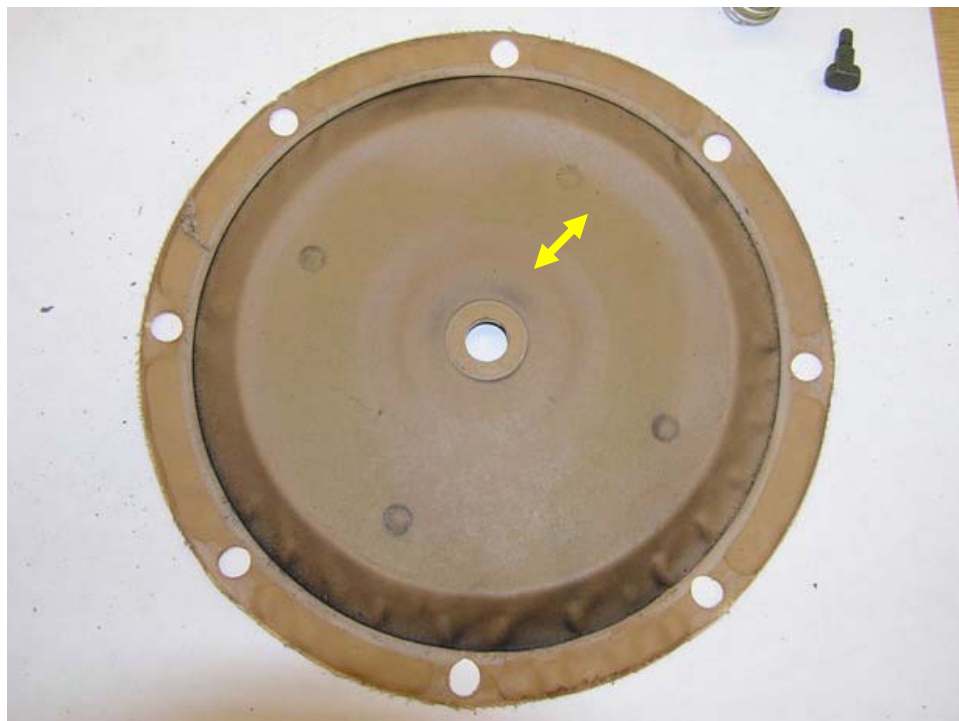

Figure 4: Bottom of Regulator #383 Diaphragm

Failure Analysis Regulator #383

The seal between the PRD stem and the diaphragm was in good condition, as shown in Figure 5. Although there was small amounts of dirt and debris in the vicinity of the seal, there was no indication that it prevented a proper seal from occurring.



Figure 5: PRD Seal on Bottom of Regulator #383 Diaphragm

The nozzle orifice was removed from the inlet of the regulator. Substantial degradation of the seat disc was apparent, as shown in Figure 6. It appears the damage is a loss of material from the seat disc (and not solely compression set). A significant amount of debris was found between the orifice and seat disc. The debris was collected in a bag and is shown in Figure 7. It is suspected that some of this debris is material lost from the seat disc.

Failure Analysis Regulator #383



Figure 6: Inlet Seat Disc on Regulator #383



Figure 7: Dirt and Debris Removed Between Nozzle Orifice and Seat Disc

The nozzle orifice is shown in Figure 8. The edge of the orifice was smooth and had no sharp edges. This indicates the damage to the seat disc was not caused by the orifice cutting the disc. A dark substance was noted on the large face of the orifice. This may be the same substance that was noted in substantial quantities on the inlet to the orifice (Figure 9). Although the exact rotational

Failure Analysis Regulator #383

position of the orifice fitting during assembly is unknown, it is probable that the dark substance gravimetrically settled out of the propane.



Figure 8: Nozzle Orifice of Regulator #383



Figure 9: Inlet Side of Nozzle Orifice of Regulator #383

Summary

Based on these observations, the following failure mechanism is proposed. Damage to the seat disc prevents a proper seal between the inlet and outlet from being formed. Under lock-up

Failure Analysis Regulator #383

conditions, leakage occurs until the outlet pressure is approximately 35 inH₂O. At this pressure enough force is generated to form the seal between the degraded seat disc and the inlet orifice. No physical cause of the damage to the seat disc was found. The dark substance on the orifice fitting may indicate the presence of an impurity in the propane that chemically attacked the seat disc.

Failure Analysis Regulator #490

Problem

Regulator #490 is an integral two-stage regulator. It failed testing because it “chatters and leaks thru PRV at 30 cfh”. It was removed from service because the installation was changed to a dual stage system.

Inspection

The outside body of Regulator #490 is in good condition, as shown in Figure 1. There is some corrosion on some of the screws holding together the body, but there is no indication that they had corroded to failure or that the body was corroded.



Figure 1: Regulator #490

A significant amount of dirt and debris was seen in the second-stage vent. Figure 2 shows the vent from both the outside and inside of the body. The vent screen was in place when the regulator was arrived; it was removed before the pictures of Figure 2 were taken. The outstanding condition of the inside of the body indicates that while there may have been noticeable corrosion or debris on the vent outlet, the vent valve was effective in preventing the majority of it from entering the regulator body.

Failure Analysis Regulator #490



Figure 2: Second-Stage Vent (Regulator #490)

The top half of the second-stage of the regulator was in good condition as well (Figure 3). The PRD spring and adjustment spring were in good condition. There was relatively little debris contained within the regulator. No damage to the diaphragm or diaphragm plate was noticed. The diaphragm itself was adhesively bonded to the diaphragm plate. This bond appeared in good condition with no large, detectable failures.



Figure 3: Top Half of Second-Stage (Regulator #490)

The bottom of the diaphragm was in similarly good condition. Two marks where the diaphragm contacted the lower body are visible at 2 o'clock and 8 o'clock in Figure 4. These marks did not cut or damage the diaphragm. The contacting surface between the diaphragm and the PRD stem was in good condition.

Failure Analysis Regulator #490



Figure 4: Bottom of Second-Stage Diaphragm (Regulator #490)

The white plastic PRD stem, as well as a portion of the lower half of the second-stage body, is shown in Figure 5. The PRD stem was in good condition. No cracks or chips were observed. The outside edge that creates the seal with the second-stage diaphragm was slightly discolored, but otherwise in good condition.

Failure Analysis Regulator #490



Figure 5: PRD Stem and Bottom of Second-Stage Body (Regulator #490)

The PRD stem was removed and the linkage assembly between the first and second stages was examined. The assembly is shown in Figure 6. The assembly appeared to be in good working order. No debris was found that would prevent proper operation of the linkage. The O-ring appeared in good condition, with no evidence of cracking or cuts.

There have been no apparent leak path from the second-stage inlet to the second-stage outlet.



Figure 6: Second-Stage Linkage Assembly (Regulator #490)

Failure Analysis Regulator #490

The first-stage portion of the regulator was more difficult to disassemble due to the use of rivets in the construction. The limited disassembly found little evidence of failure. Figure 7 shows the first-stage portion of this regulator. There is some paint on the outer edges of the diaphragm, but none appears to extend into the working seals of the regulator. No significant dirt or debris was found in this portion of the regulator. The diaphragm itself was in good condition; No cracks or cuts were observed. It was impossible to non-destructively disassemble the outlet side of the first-stage of the regulator to examine the sealing surface of the rubber cap.



Figure 7: First-Stage Portion of Regulator #490

Figure 8 shows the inlet side of the first-stage portion of this regulator. The spring was in good condition. No dirt or debris was found in this side of the regulator either. The bond between the diaphragm and the plate was in good condition with no noticeable gaps or leak paths.

Failure Analysis Regulator #490



Figure 8: Inlet Side of First-Stage Portion of Regulator #490

The O-ring seal on the shaft pass-through from the inlet to the outlet was in good condition. Note that the O-ring shown in Figure 9 has been pushed up during the examination. No leak path was observed around the O-ring. Note that the plate and threads of the shaft show signs of some scale buildup. The scale buildup was generally small in nature, and no significant amounts of loose scale or debris were observed.



Figure 9: First-Stage Diphragm (Regulator #490)

Failure Analysis Regulator #490

Summary

No failure mode was found for this regulator. The inside of the regulator body was generally clean. All observable seals were in good condition. There was nothing observed that would block or impair the normal motion of either the first or the second-stage linkages.

Failure Analysis Regulator #538

Problem

This first stage regulator “leaks thru PRD at 25 psig inlet and 0 cfh; high lock-up”. It was removed from service because the tank and regulator were both removed from the service at location.

Inspection

The outside of the regulator body is in good shape. There are some small bits of dirt and spiderweb on the relief screen, but not enough to cause any significant blockage.



Figure 1: Regulator #538

Upon disassembly possible leak paths between the high pressure inlet and the pressure relief opening were identified. The two general areas are the diaphragm assembly and by the O-ring seal on the shaft.

Failure Analysis Regulator #538

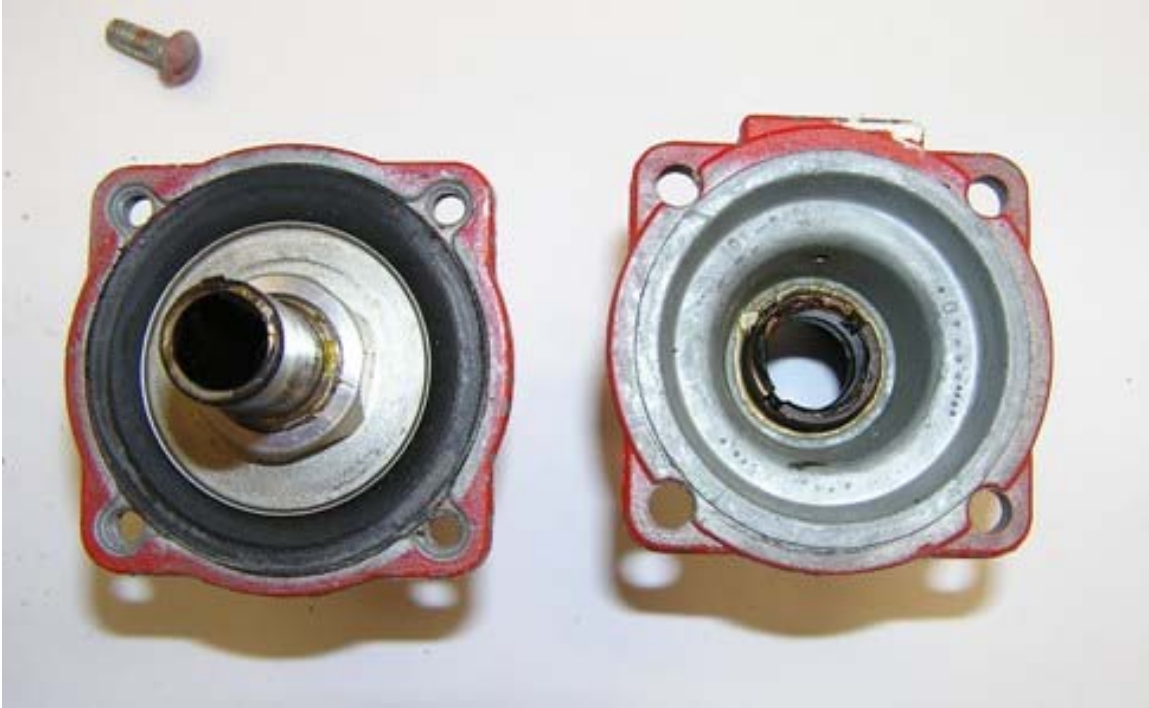

Figure 2: Two halves of the body of #538 showing the two general leak interfaces, main diaphragm (left) and O-ring seal on shaft (right)

A detailed visual inspection of the diaphragm (Figure 3) did not identify any potential leak paths. The diaphragm appeared in good shape; there were no cuts, holes, scratches, cracks, or any other evidence of failure. Permanent deformation at the sealing edges did not indicate any leak paths. The ridge on the outside of the diameter was discernible for the entire circumference. The height of the ridge was non-uniform along the circumference. One side in particular was somewhat lower than the rest. However, this is not suspected to be a problem because a leak on the outside circumference of the diaphragm would manifest itself as a body-leak and not the observed PRD leak. Furthermore, even though the height was not as great, the ridge was still there, indicating that the two halves of the body were tightened together adequately. The other sealing edge of the diaphragm is on the inside circumference where the shaft passes through. A leak through this interface would result in a leak through the PRD. However, the interface appeared good. There was a uniform ridge inside the edge of the interface between shaft and the diaphragm indicating adequate tightening of the joint. There was no debris, cuts, scrapes, tears, or any other indication that the seal between the shaft and the diaphragm was faulty.

Failure Analysis Regulator #538



Figure 3: Main Diaphragm of #538. Note the Zig-Zag marks on the surface were put there during disassembly of the diaphragm/shaft.

A detailed inspection of the shaft (Figure 4) identified a potential leak path to the PRD. During manufacture the shaft was turned to a smooth finish, as indicated by the pattern of small circumferential lines. There was a large diagonal scrape along the shaft, as show in Figure 4. The shaft is discolored at the very end (just right of the circle marking the diagonal scrape) where it extended beyond the O-ring seal interface and into the propane flow. A circumferential mark through the middle of the diagonal scrape is the normal operating location of the O-ring. Although the diagonal scrape does not appear very deep, this is the most probable observed leak path to the PRD opening. The O-ring was not removed for inspection since the removal would likely damage the O-ring, making it impossible to distinguish between a previous failure and the current destructive process.

Failure Analysis Regulator #538

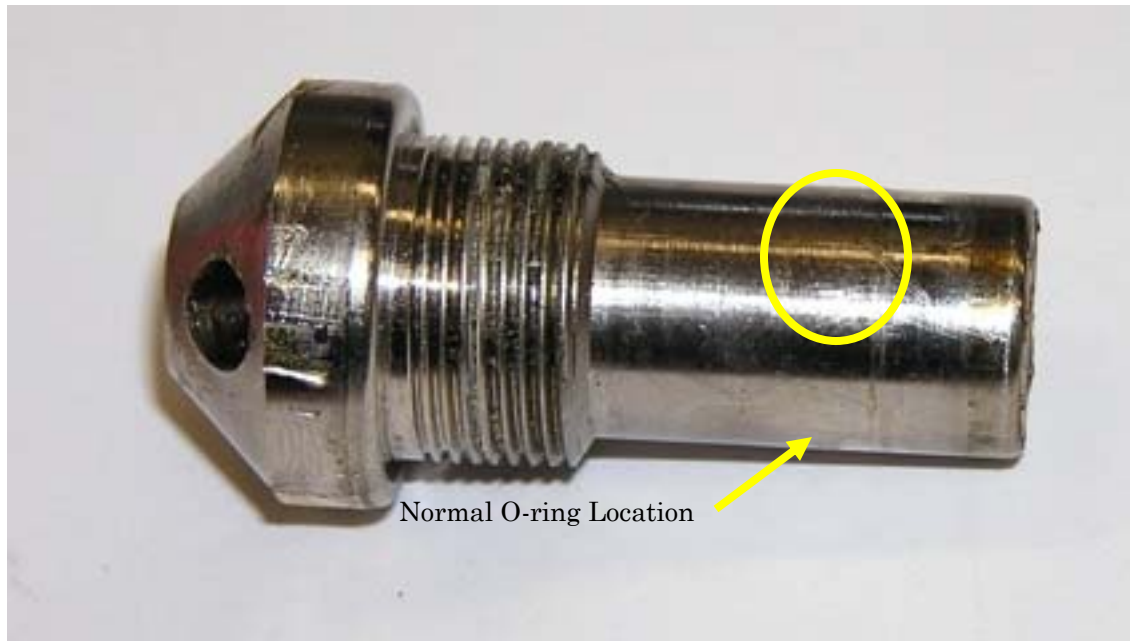

Figure 4: Shaft of Regulator #538

Summary

Based on the observations, the most probable leak path is past the O-ring, through the diagonal scratch on the shaft.

Failure Analysis Regulator #571

Problem

This first-stage regulator “leaked through PRD during adjustment”.

Inspection

Regulator 571 is shown below in Figure 1. This regulator arrived painted fully painted. The paint was removed from the top half of the body in order to locate the manufacture date stamp on the regulator.



Figure 1: Regulator #571

The top half of the body was removed and the inside examined. The upper half of the regulator appeared to be in good condition. It was relatively clean and showed no signs of damage.

Failure Analysis Regulator #571



Figure 2: Regulator #571 with Top of Body Removed

The diaphragm and PRD spring were removed and the bottom half of the regulator body was inspected. There was a significant amount of grit, paint particles, and other debris in the bottom of the regulator. Included in the debris were two large metal shavings. The debris (including the metal shavings) are shown in Figure 3. It is possible that the metal shavings were located below the linkage in the bottom of the regulator body, inhibiting the full range of movement and preventing the inlet from closing.

Failure Analysis Regulator #571



Figure 3: Particles and Shavings (circled) Found inside Bottom of Regulator #571

The diaphragm was removed and inspected. Overall the diaphragm was in good condition, with no cuts, scrapes, cracks, or other signs of damage. The diaphragm plate was bonded to the diaphragm. The bond appeared to be in good condition with no noticeable gaps in its coverage. The seal with the PRD stem on the underside of the diaphragm was in good condition. There was no debris or evidence of a leak path through the sealing interface.

Failure Analysis Regulator #571



Figure 4: Bottom of Diaphragm (Regulator #571)

The control linkage was removed and inspected. The plastic parts of the linkage assembly were in good condition. No chips, breaks, or fractures were observed. There was some white powder observed on the sides of the PRD stem, indicating slight wear. The O-ring on the linkage assembly had a dried white residue on its surface. This did not seem to affect the quality of the O-ring; the outer surface was smooth with no cracks, scrapes, or signs of degradation.

Failure Analysis Regulator #571



Figure 5: Control Linkage Assembly (Regulator #571)

The seat disc from the control linkage assembly was examined. There was a hard edge on one side of the seat impression. Additionally there was a fair amount of grit covering the entire face of the rubber seal.

Failure Analysis Regulator #571



Figure 6: Seat Disc from Control Linkage (Regulator #571)

Summary

Based on the inspection, the most probable explanation for leakage through the PRD was the presence of metal shavings in the lower half of the body. The metal shavings prevented the control linkage assembly from fully closing the inlet to the regulator, thereby allowing excess pressure to build up within the regulator body.

Alternatively, it could have been the grit on the seat disc that caused the PRD to discharge under normal operating conditions. The grit could have prevented the inlet from being completely sealed when the desired regulated pressure was realized.

The sealing interfaces between the control linkage and diaphragm (PRD stem seal) and between the control linkage and body (O-ring) were in good condition and there was no indication that these were leak paths from the inlet.

Failure Analysis Regulator #711

Problem

This second-stage regulator did not relieve during the relief test.

Inspection

Regulator 711 is shown in Figure 1. In this picture, it is apparent there are substantial amounts of spider webs in the vent.



Figure 1: Regulator #711

Figure 2 is a close up of the vent, taken before any cleaning or inspection. It is apparent that the vent screen is not in place, allowing for the spider webs to freely enter the inside of the regulator body.

Failure Analysis Regulator #711



Figure 2: Regulator #711 Vent

The spider webs were removed from the vent. The vent passage (approximately 1/8" in diameter) was completely plugged by dirt and old spider webs. Figure 3 shows the vent after the spider webs were removed and the vent path cleared.

Failure Analysis Regulator #711



Figure 3: Regulator #711 Vent (After Cleaning)

Several dead insects were found inside the regulator body, as shown in Figure 4. The diaphragm plate, PRD spring, and associated assembly were in good condition. There was no indication that the PRD itself failed to actuate.



Figure 4: Inside Body of Regulator #711

Failure Analysis Regulator #711

Summary

It has been determined that this regulator failed the relief test since the vent passage was blocked by mud. There was no indication that the PRD itself failed to actuate to excess pressure.